

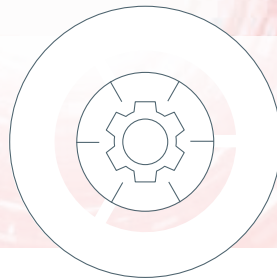

PRODUCT INFORMATION
GHM GROUP



Temperature.





Characteristics

- **System**

- Temperature probes
- Temperature probes with integrated transmitter
- Temperature probes with data logger
- Transmitter
- Temperature monitors
- Displays

Function and advantages

The measuring and monitoring of temperature with resistance thermometers or thermocouples is the most common method to watch and control processes. Here the temperature gets a electrical unit by using the thermoelectric effect (thermocouple) or a resistance change. This measuring value can be converted to standard signals by our transmitter for further usage.

Technical data

Temperature probes

- Measuring input – sensor element
- Resistance thermometer Pt100 / Pt1000
- Thermocouple type K (NiCr-Ni), type J (FeCuNi), type N (NiCrSi-NiSi)

Particular features

- Multitude of probes suitable for each application
- Temperature probes customized according to customer requirements
- ATEX protection

Applications

- Industrial measurement and control technology
- Process measurement
- Pipeline and tank construction
- Furnace construction
- Plastics industry
- Food industry
- Surface measurements
- Plant and machine construction
- Room temperature measurement
- ⚠ - applications
- SIL 2 - applications

Accuracy:

Pt100 / Pt1000:

Sensor accuracy according to DIN EN 60751

DIN class	Scope	Accuracy
DIN cl. B	-50..+500 °C	±0,3 °C bei 0 °C
DIN cl. A	-30..+300 °C	±0,15 °C bei 0 °C
1/3 DIN cl. B = DIN Kl. AA	0..150 °C	±0,1 °C bei 0 °C
1/10 DIN cl. B		±0,03 °C bei 0 °C

Thermocouple:

Sensor accuracy according to DIN EN 60584-2

Thermocouple	Class	Scope	Accuracy
Typ K	class 1	-40..+375 °C	±1,5 °C
Typ N	class 1	-40..+375 °C	±1,5 °C
Typ S	class 1	0..1100 °C	±1 °C

Product information Flow - Temperature

Temperature probes with data logger

Measuring input – sensor element

- Resistance thermometer Pt1000

Particular features

- Battery supply (service life approx. 6 years)
- Temperature probe with integrated transmitter and data logger with memory for up to 48,000 measuring values
- Integrated display

Temperature probes with integrated transmitter

Measuring input – sensor element

- Resistance thermometer Pt100 / Pt1000
- Thermocouple type K
- Infrared
- Radio

Particular features

- Multitude of probes / transmitter, suitable for each application
- Probes / transmitters customized according to customer requirements
- Integrated or optional display

Transmitters

Measuring input

- Resistance thermometer Pt100 / Pt500 / Pt1000, Resistance thermometer Ni100 / Ni500 / Ni1000
- Thermocouple type B, type C, type D, type E, type J, type K, type L, type N, type R, type S, type T, type U

Particular features

- Multitude of transmitter, suitable for each application
- Transmitters customized according to customer requirements
- Integrated or optional display
- ATEX protection
- SIL2 application

Temperature monitors

Measuring input – sensor element

- Resistance thermometer Pt100 / Pt1000,
- Thermocouple type J, type K, type N, type S
- Bimetal
- Micro switch

Particular features

- Multitude of monitors, suitable for each application
- Temperature monitors customized according to customer requirements
- Integrated display
- ATEX protection

Displays

Measuring input – sensor element

- Resistance thermometer Pt100 / Pt1000
- Thermocouple type J, type K, type S

Particular features

- Temperature measuring device with display
- Field housing or housing for control cabinet mounting

Device overview

Temperature probes	Description	Measuring element					Page
		Pt100	Pt1000	Type J Fe-CuNi	Type K NiCr-Ni	Type N NiCr-Si-NiSi	
GTF 300	Wire probe				•		7
GMF 250	Magnetic surface probe				•		7
GMF 200	Magnetic surface probe				•		8
GRO 200	Tube surface probe	•	•		•		9
7122	Tube surface probe			•	•		10
7131	Surface probe	•					11
GTT	Sheathed thermocouple				•		12
GTF 101 P ..	Temperature probe	•	•				13
GTF 101 K ..	Temperature probe				•		15
7132	Temperature probe	•		•	•		17
7024 / 7124	Temperature probe	•		•	•		18
7012 / 7112	Temperature probe with thread spring	•		•	•		19
GES 21	Penetration probe	•	•				20
GTF 102	Screw-in probe	•	•		•		21
8100 A / 8100 C	Installation temperature probe	•	•	•	•		22
8101 A	Installation temperature probe	•	•	•	•		23
8105	Duct temperature probe	•		•	•		24
GTF 101 Ex	EX temperature probe without process connection	•	•		•	•	25
GTF 102-Ex	EX temperature probe without process connection	•	•		•	•	26
GTF 103-Ex	EX temperature probe with process connection, with sensor head	•	•		•	•	28
TC293	Safety thermocouple probe			•	•	•	30
TR293	Safety temperature probe	•					31
TC296	Safety thermocouple probe			•	•	•	32
TR296	Safety temperature probe	•					33
7134 / 7135	Surface-mounted probe)	•					34
GTMU-OMU	Surface-mounted probe)	•			•		35

Temperature probes with data logger	Description	Measuring element					Page
		Pt100	Pt1000	Type J Fe-CuNi	Type K NiCr-Ni	Type N NiCr-Si-NiSi	
EASYLog 40K EASYLog 40KH EASYLog 40KH-E300 EASYLog 40KH-E600 EASYLog 40KH-GOF	Temperature data logger		• • • • •				37

Temperature probes with integrated transmitter	Description	Measuring element / measuring technology						Page
		Pt100	Pt1000	Type K NiCr-Ni	Radio	Infrared	Others	
GTMU	Temperature probe with transmitter	•		•				39
GTMU-MP	Temperature probe with transmitter		•					43
GTMU-IF	Compact temperature transmitter		•					43
ETS	Temperature transmitter		•					44
ETK12-I/U/F	Temperature transmitter						•	46
ETK12-S	Temperature switch						•	49
FLEX-T	Temperature transmitter / switch		•				•	52
OMNI-T	Temperature transmitter / switch (with display)		•				•	56
ETSD	Temperature difference transmitter	•						61
RF1-T	Radio temperature transmitter / switch		•		•			65
IR-CT 20	Infrared thermometer					•		67

Transmitters	Description	Measuring input									Page
		Pt100	Pt1000	Type J Fe-CuNi	Type K NiCr-Ni	Type N NiCr-Si-NiSi	Type S Pt10Rh-Pt	Resistance signal	Voltage signal	Others	
T19	Head transmitter	•									69
T03 BU	Analog head transmitter	•									70
RT420	Head transmitter / transmitter	•									71
GITT01	Universal head transmitter	•	•	•	•	•	•	•	•	•	72
GTMU-A5	Transmitter	•			•						74
MU500L	Transmitter	•	•								76
MU500	Transmitter	•	•								77
MU500EX	Transmitter	•	•								78
TC500	Transmitter			•	•		•				79
PMT50-2-3	Transmitter	•	•	•	•	•	•				80
PMT50EX-2-3	Transmitter	•	•	•	•	•	•				82
ISO-TC	Transmitter / signal conditioner			•	•					•	84
ISO-Pt100	Transmitter / signal conditioner	•									85
CAN-Compactmodule	Transmitter / signal conditioner	•		•	•						86

Geräteübersicht

Temperature monitors	Description	Measuring input								Page	
		Pt100	Pt1000	Type J Fe-CuNi	Type K NiCr-Ni	Type N NiCr-Si-NiSi	Type S Pt10Rh-Pt	Bimetal	Micro switch		Others
TG50	Temperature guard	•	•	•	•	•	•				87
TG50EX	Temperature guard	•	•	•	•	•	•				89
TF1	Temperature controller							•			91
TR	Temperature controller								•		92
TB225	Temperature limiter	•		•	•	•	•				93
STL50	Safety temperature limiter	•		•	•	•	•				95
STL50EX	Safety temperature limiter	•		•	•	•	•				97
GS1000	Limit value relay	•		•	•		•				99

Displays	Description	Measuring input					Page
		Pt100	Pt1000	Type J Fe-CuNi	Type K NiCr-Ni	Type S Pt10Rh-Pt	
T1010	Temperature Meter	•	•				101
T9648	Temperature Panelmeter	•	•	•	•	•	102

Accessories	Description	Page
<ul style="list-style-type: none"> • VKA • S2P, G2P, T2P, P2P, ... • AGL • KB, K PU, K05 PU • OMNI-TA • GKV • NST, NKU, • EST • GWL10G • ECI-1 	<ul style="list-style-type: none"> Extension cable Various cables Compensation lines Round plug connector Clamping ring screw connection Plat-pin connector, thermoelectric-voltage free Immersion sleeve Heat conducting paste Converter / Counter Device Configurator 	104

Wire Probe GTF 300



- NiCr-Ni wire probe (type K)
- Quick-response measurements in air, gases, liquids
- For very small surfaces

Characteristics

The GTF 300 is a NiCr-Ni (type K) wire probe for quick-response measurements in air, gases or liquids. The GTF 300 with option "UV" can be also used for measurements of very small surfaces. For option "UV" (untwisted welded) the measuring point is placed at the sensor tip.

The thermocouple consists of two electric lines made of different materials (NiCr and Ni). The measuring principle of temperature measurement with thermocouples is based on the existence of thermovoltage when two wires made of different materials are connected.

The probe is delivered with ready-to-use, thermovoltage-free miniature flat-pin plug NST1200.

Technical Data

Thermocouple	: NiCr-Ni (type K)
Measuring range	: -65..+300 °C
Response time (T ₉₀)	: approx. 0.3 s
Accuracy	: class 1
Thermocouples wires	: 1 m Teflon insulated twisted wires (max. 250 °C), very flexible diameter approx. 1.0 mm
Measuring point	: connection point of wires measuring tip (twisted welded)
Connection	: miniature flat-pin plug NST1200

Dimensions

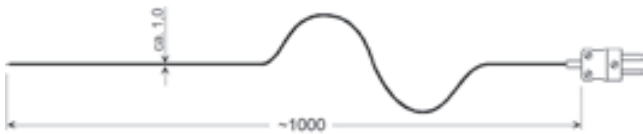

Ordering code

GTF300 - 1. - 2.

1. Wire length	
01	1 m (standard)
xx	desired length in m (up to 50 m) e.g. 25 = 25 m
2. Option	
00	without option
UV	measuring tip untwisted welded

Magnetic Surface Probe GMF 250

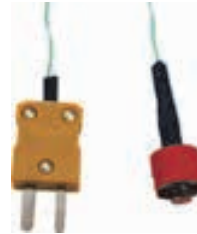

- NiCr-Ni-probe (type K)
- Self-adhesive on magnetic surfaces
- Resilient measuring sensor

Characteristics

The GMF 250 is a NiCr-Ni (type K) magnetic surface probe for surface temperature measurements. The GMF 250 is used exclusively for magnetic materials, because of its self-adhesive measuring sensor with Cu-plate. The probe is not appropriate for use at induction furnace, etc.

The thermocouple consists of two electric lines made of different materials (NiCr and Ni). The measuring principle of temperature measurement with thermocouples is based on the existence of thermovoltage when two wires made of different materials are connected.

The probe is delivered with ready-to-use, thermovoltage-free miniature flat-pin plug NST1200.

Technical Data

Thermocouple	: NiCr-Ni (type K)
Measuring range	: -65..+250 °C
Response time (T ₉₀)	: approx. 5 s
Accuracy	: class 1
Thermocouples wires	: 1 m Teflon insulated twisted wires (max. 250 °C), very flexible diameter approx. 1.0 mm
Measuring point	: magnetic, resilient measuring sensor with Cu-plate Ø 5 mm
Connection	: miniature flat-pin plug NST1200

Dimensions

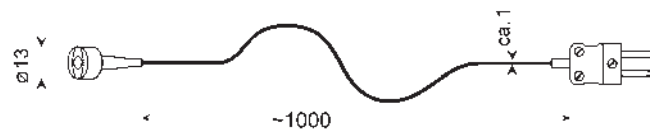

Ordering code

GMF250 - 1.

1. Wire length	
01	1 m (standard)
xx	desired length in m (up to 50 m) e.g. 25 = 25 m

Magnetic Surface Probe GMF 200



- NiCr-Ni-probe (type K)
- Self-adhesive on magnetic surfaces (reinforced design)
- Resilient measuring sensor

Characteristics

The GMF 200 is a NiCr-Ni (type K) magnetic surface probe for surface temperature measurements. The GMF 200 is used exclusively for magnetic materials, because of its self-adhesive measuring sensor with Cu-plate. The probe is not appropriate for use at induction furnace, etc.

The thermocouple consists of two electric lines made of different materials (NiCr and Ni). The measuring principle of temperature measurement with thermocouples is based on the existence of thermovoltage when two wires made of different materials are connected.

The probe is delivered with ready-to-use, thermovoltage-free miniature flat-pin plug NST1200.

Technical Data

Thermocouple	: NiCr-Ni (type K)
Measuring range	: -65..+200 °C
Response time (T ₉₀)	: approx. 5 s
Accuracy	: class 1
Thermocouples wires	: 2 m silicone cable (max. 200 °C) flexible and robust
Measuring point	: strong magnetic, resilient measuring sensor with Cu-plate Ø 5 mm
Connection	: miniature flat-pin plug NST1200

Dimensions

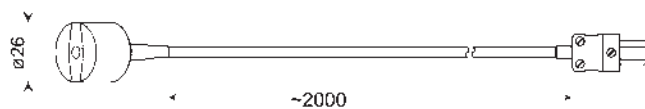

Ordering code

1.
GMF200 -

1.	Wire length
02	2 m (standard)
xx	desired length in m (up to 50 m) e.g. 25 = 25 m

Tube Surface Probe GRO 200



- For round surfaces
- Pt100, Pt1000, NiCr-Ni
- Aluminum probe

Characteristics

The GRO is a temperature probe especially designed for round surfaces (e.g. tubes). The probe body is made of aluminum.

The measurement is done by means of a resistive temperature sensor (Pt100 / Pt 1000) or thermocouple (type K, NiCr-Ni).

The probe is delivered with 2 m silicone cable with loose ends and end sleeves by default. The probe can be mounted by for example the cable clip GWL5g. We strongly recommend to use heat conducting paste for better heat transfer.

Technical data

Sensor element	: Pt100 (4-wire) Pt1000 (4-wire) NiCr-Ni
Measuring range	: -50..+200 °C
Accuracy	: Pt100 / Pt1000: DIN class B NiCr-Ni: class 1
Probe material	: aluminum
Connection cable	: silicone cable or silicone compensation line, loose ends length: 2 m (up to max. 200 °C)

Dimensions

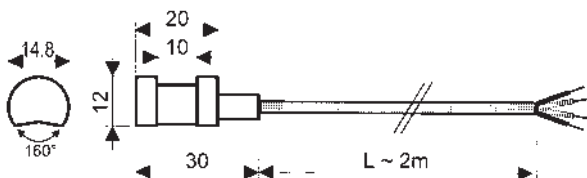

Ordering code

GRO200 - 1. - 2.

1. Sensor element	
P	Pt100 (4-wire)
T	Pt1000 (4-wire)
K	NiCr-Ni
2. Cable length L	
L02	2 m (standard)
Lxx	desired length in m (e.g. L04 = 4 m)

Temperature Sensor 7122



Characteristics

- Thermocouple Fe-CuNi (type J); NiCr-Ni (type K)
- RTD Pt100, class B
- Pipe clamp, protection spring stainless steel 1.4541 protection sheath silver, thermal isolated
- Cable type flexible fiberglass insulation with steel wire braiding or Teflon-Silicon-insulation

Dimensions

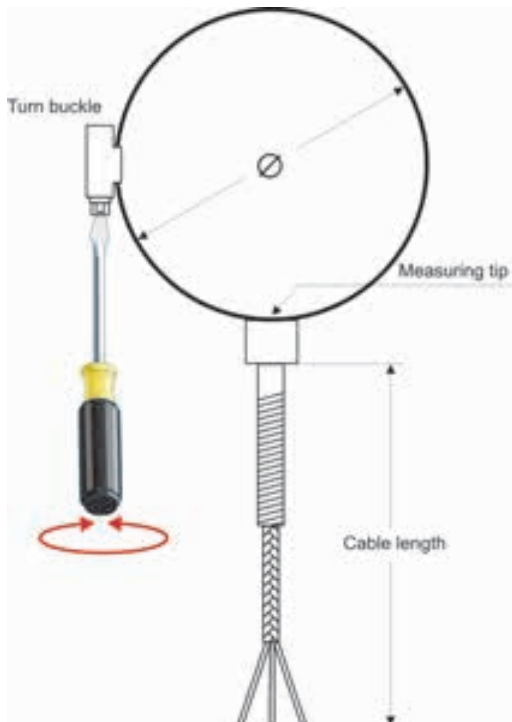

Ordering code

1. 2. 3. 4. 5. 6. 7.
 - - - - - -

1. Measuring element	7122	Pt100 class B
2. Number of elements	1	
	2	
3. Connection type	2L	2-wire
	3L	3-wire
	4L	4-wire
4. Clamp range of pipe clamp	68	Ø 16-25 mm
	69	Ø 20-32 mm
	70	Ø 32-50 mm
	71	Ø 50-70 mm
	72	Ø 70-90 mm
	73	Ø 90-110 mm
	74	Ø 110-130 mm
5. Cable length (please state in clear text)	2000	Cable length in mm standard
	XXXX	custom length in mm; price/m
6. Operating temperature	250°C	in glass silk – stainless conduction

Stock

- 7122-1-3L-68-2000-250°C
- 7122-1-3L-69-2000-250°C
- 7122-1-3L-70-2000-250°C
- 7122-1-3L-71-2000-250°C
- 7122-1-3L-72-2000-250°C
- 7122-1-3L-73-2000-250°C
- 7122-1-3L-74-2000-250°C

Temperature Sensor 7131



Characteristics

- Thermocouple Fe-CuNi (type J); NiCr-Ni (type K)
- RTD Pt100, class B
- Surface sensor
- Sensor case brass nickel plated
- Cable type flexible fiberglass insulation with steel wire braiding or Teflon-Silicon-insulation

Dimensions

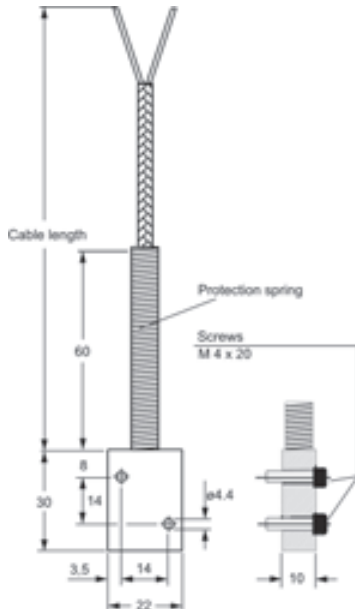

Ordering code

1. 2. 3. 4. 5. 6.
□ - □ - □ - □ - □ - □

1. Measuring element	
7131	Pt100 class B
2. Number of elements	
1	
2	
3. Connection type	
2L	2-wire (standard)
3L	3-wire
4L	4-wire
4. Cable length (please state in clear text)	
2000	cable length in mm standard
XXXX	custom length in mm; price/m
5. Operating temperature	
400°C	fiberglass insulation

Stock

7131-1-2L-2000-400°C

Sheathed Thermocouple GTT



- NiCr-Ni thermocouple (type K)
- With thermovoltage-free miniature flat-pin plug

Characteristics

The GTT is a NiCr-Ni (type K) sheathed thermocouple for temperature measurement. Its compact design allows application at measuring points with difficult access.

The thermocouple consists of two electric lines made of different materials (NiCr and Ni). The measuring principle of temperature measurement with thermocouples is based on the existence of thermovoltage when two wires made of different materials are connected.

The probe is delivered with ready-to-use, thermovoltage-free miniature flat-pin plug NST1200. Measuring errors due to different materials are prevented by the thermovoltage-free miniature flat-pin plug. Additionally the DIN plug can be connected to a lot of different handheld measuring devices.

Technical data

Sensor element	: NiCr-Ni (type K)
Measuring range	: -200..+1150 °C
Accuracy	: class 1
Sheath material	: Inconel 600, bendable
Isolation	: highly compressed pure MgO
Thermocouple	: wires made of NiCr-Ni, DIN IEC 584, isolated, welded (potential-free)
Connection	: miniature flat-pin plug NST1200

Dimensions



Ordering code

GTT - 1. - 2.

1. Probe diameter D		
D05	0.5 mm	up to max. 600 °C
D10	1.0 mm	up to max. 600 °C
D15	1.5 mm	up to max. 600 °C
D30	3.0 mm	
D60	6.0 mm	
2. Fitting length EL (±10mm)		
0150	150 mm	
0250	250 mm	
0500	500 mm	
1000	1000 mm	
1500	1500 mm	

Temperature Probe GTF 101 P

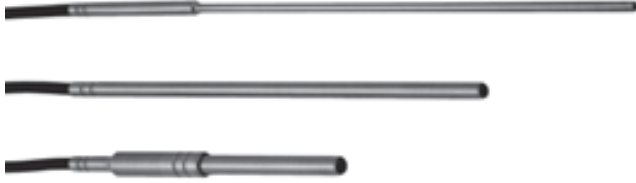

- Pt100, Pt1000
- With cable sleeve and cable (loose ends)
- Very robust

Characteristics

The GTF 101 is a temperature probe modified completely according to customer specifications. The GTF 101 is very robust and therefore especially suited for application at high permanent temperatures in air, gases liquids or aggressive environments.

The measurement is done by means of resistance temperature sensors (Pt100 or Pt1000)

Technical data

Sensor element	: Pt100 (2- / 3- or 4-wire) Pt1000 (2- / 3- or 4-wire)
Measuring range MB	
MB 1	: -50..+400 °C
MB 2	: -200..+400 °C
MB 3	: -200..+600 °C
MB 4	: -50..+850 °C
Probe diameter D	: 3 mm, 4 mm, 5 mm, 6 mm, 8 mm other diameters (e.g. 1.6 mm, 2.2 mm) upon request
Fitting length EL	: 50 mm, 100 mm, 150 mm, 250 mm, 500 mm, 1000 mm, 1500 mm other fitting lengths possible
Cable sleeve	: for probe diameter D 3 mm, 4 mm, 5 mm, 6 mm, 8 mm: cable sleeve Ø 5 mm x 50 mm additional to fitting length for probe diameter D 6 mm and MB3 or MB4: cable sleeve Ø 8 mm x 35 mm and diminution Ø 5 mm x 17 mm additional to fitting length
Note:	: The temperature of the cable sleeve must not exceed the permitted temperature of the cable
Accuracy	: DIN class B, DIN class A, 1/3 DIN class B, 1/10 DIN class B
Tube material	: V4A
Cable	: 1 m (standard), loose ends
PVC cable	: up to max. 105 °C
Silicone cable	: up to max. 200 °C (standard)
Teflon cable	: up to max. 250 °C
Glass silk cable	: up to max. 400 °C

Dimensions

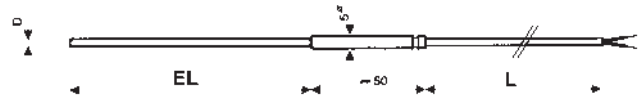

Ordering code

GTF101P - 1. - 2. - 3. - 4. - 5. - 6. - 7. - 8.

1. Sensor element	
P	Pt100
T	Pt1000
2. Connection of sensor element	
2L	2-wire
3L	3-wire
4L	4-wire
3. Accuracy	
A	DIN class A <i>only with MB1</i>
B	DIN class B (Standard)
D	1/3 DIN class B <i>only with MB1, MB2, MB3</i>
Z	1/10 DIN class B <i>only with MB1 and Pt100</i>
4. Measuring range MB	
MB1	-50..+400 °C
MB2	-200..+400 °C
MB3	-70..+600 °C
MB4	-50..+850 °C <i>only with Pt100</i>
5. Probe diameter D	
D30	3.0 mm
D40	4.0 mm
D50	5.0 mm
D60	6.0 mm
D80	8.0 mm <i>not with MB4</i>
Dxx	other Ø in mm (upon request)
6. Fitting length EL	
0050	50 mm
0100	100 mm
0150	150 mm
0250	250 mm
0500	500 mm
1000	1000 mm
1500	1500 mm
xxxx	any EL in mm (e.g.: 0700 = 700 mm)
7. Cable length L	
L01	1 m (standard)
Lxx	desired length in m (e.g. L03 = 3 m)
8. Cable material	
P	PVC cable up to max. 105 °C
S	silicone cable up to max. 200 °C (standard)
T	Teflon cable up to max. 250 °C
G	glass silk cable up to max. 400 °C

Temperatur Probe GTF 101 P-OKH

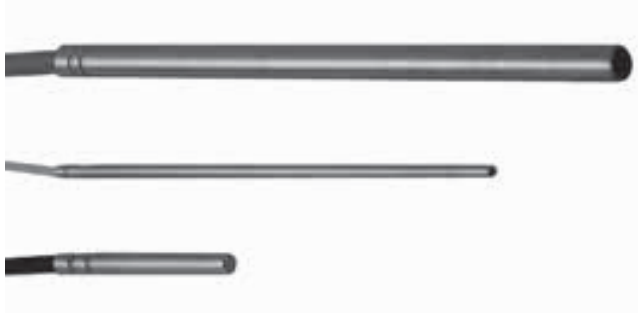

- Pt100, Pt1000
- With cable (loose ends)
- Very robust

Characteristics

The GTF 101 is a temperature probe modified completely according to customer specifications. The GTF 101 is very robust and therefore especially suited for application at high permanent temperatures in air, gases liquids or aggressive environments.

The measurement is done by means of resistance temperature sensors (Pt100 or Pt1000)

Technical data

Sensor element	: Pt100 (2- / 3- or 4-wire) Pt1000 (2- / 3- or 4-wire)
Measuring range MB	
MB 1	: -50..+200 °C
MB 2	: -50..+250 °C
MB 3	: -50..+400 °C
MB 4	: -200..+250 °C
Probe diameter D	: 3 mm, 4 mm, 5 mm, 6 mm, 8 mm other diameters upon request
Fitting length EL	: 50 mm, 100 mm, 150 mm, 250 mm, 500 mm, 1000 mm, 1500 mm other fitting lengths possible
Accuracy	: DIN class B, DIN class A, 1/3 DIN class B, 1/10 DIN class B
Tube material	: V4A
Cable	: 1 m (standard), loose ends
Silicone cable	: up to max. 200 °C (standard)
Teflon cable	: up to max. 250 °C
Glass silk cable	: up to max. 400 °C

Dimensions



Ordering code

GTF101P-OKH - 1. - 2. - 3. - 4. - 5. - 6. - 7. - 8.

1. Sensor element	
P	Pt100
T	Pt1000
2. Connection of sensor element	
2L	2-wire
3L	3-wire
4L	4-wire
3. Accuracy	
A	DIN class A
B	DIN class B (Standard)
D	1/3 DIN class B
Z	1/10 DIN class B <i>only with Pt100</i>
4. Measuring range MB	
MB1	-50..+200 °C
MB2	-50..+250 °C <i>only with Teflon or glass silk cable</i>
MB3	-50..+400 °C <i>only with glass silk cable</i>
MB4	-200..+250 °C <i>only with Teflon cable</i>
5. Probe diameter D	
D30	3.0 mm <i>only with Teflon cable</i>
D40	4.0 mm <i>only with Teflon cable</i>
D50	5.0 mm
D60	6.0 mm
D80	8.0 mm
Dxx	other Ø in mm (upon request)
6. Fitting length EL	
0050	50 mm
0100	100 mm
0150	150 mm
0250	250 mm
0500	500 mm
1000	1000 mm
1500	1500 mm
xxxx	any EL in mm (e.g.: 0700 = 700 mm)
7. Cable length L	
L01	1 m (standard)
Lxx	desired length in m (e.g. L03 = 3 m)
8. Cable material	
S	silicone cable up to max. 200 °C (standard)
T	Teflon cable up to max. 250 °C
G	glass silk cable up to max. 400 °C

Temperature Probe GTF 101 K

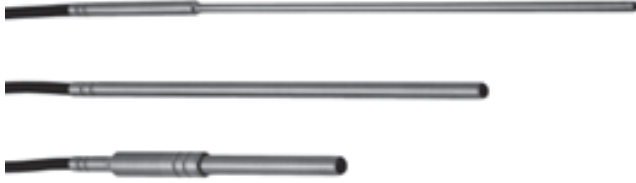

- NiCr-Ni (type K)
- With cable sleeve and cable (loose ends)
- Very robust

Characteristics

The GTF 101 is a temperature probe modified completely according to customer specifications. The GTF 101 is very robust and therefore especially suited for application at high permanent temperatures in air, gases liquids or aggressive environments.

The measurement is done by means of thermocouple wires (NiCr-Ni).

Technical data

- Sensor element** : NiCr-Ni (type K)
Measuring range : -200..+1150 °C
Probe diameter D : 0.5 mm, 1 mm, 1.5 mm, 3 mm, 6 mm
 other diameters upon request
Fitting length EL : 150 mm, 250 mm, 500 mm, 1000 mm,
 1500 mm, other fitting lengths possible
Cable sleeve : **for probe diameter D 0.5 mm,
 1 mm, 1.5 mm, 3 mm:**
 cable sleeve Ø 5 mm x 50 mm additional
 to fitting length
for probe diameter D 6 mm:
 cable sleeve Ø 8 mm x 35 mm and
 diminution Ø 5 mm x 17 mm additional
 to fitting length
Note: : The temperature of the cable sleeve
 must not exceed the permitted
 temperature of the cable
Accuracy : class 1
Tube material : cable sleeve: V4A
 probe tube: Inconel 600
Cable : 1 m silicone compensation line (std),
 loose ends
 PVC cable : up to max. 105 °C
 Silicone cable : up to max. 200 °C (standard)
 Teflon cable : up to max. 250 °C
 Glass silk cable : up to max. 400 °C

Dimensions



Ordering code

GTF101K - - - -

1. 2. 3. 4.

1. Probe diameter D	
D05	0.5 mm
D10	1.0 mm
D15	1.5 mm
D30	3.0 mm
D60	6.0 mm
Dxx	other Ø in mm (upon request)
2. Fitting length EL	
0150	150 mm
0250	250 mm
0500	500 mm
1000	1000 mm
1500	1500 mm
xxxx	any EL in mm (e.g.: 0100 = 100 mm)
3. Cable length L	
L01	1 m (standard)
Lxx	desired length in m (e.g. L03 = 3 m)
4. Cable material (compensation line)	
P	PVC cable up to max. 105 °C
S	silicone cable up to max. 200 °C (standard)
T	Teflon cable up to max. 250 °C
G	glass silk cable up to max. 400 °C

Temperatur Probe GTF 101 K-OKH

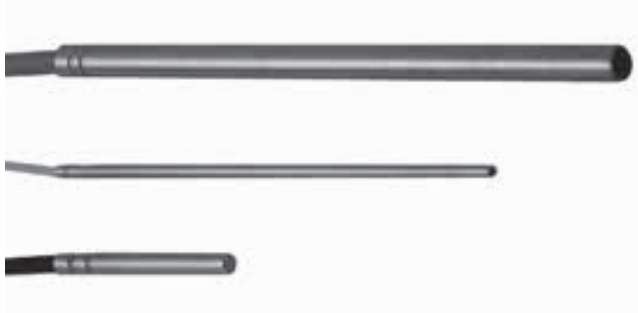

- NiCr-Ni (type K)
- With cable (loose ends)
- Very robust

Characteristics

The GTF 101 is a temperature probe modified completely according to customer specifications. The GTF 101 is very robust and therefore especially suited for application at high permanent temperatures in air, gases liquids or aggressive environments.

The measurement is done by means of thermocouple wires (NiCr-Ni).

Technical data

Sensor element	: NiCr-Ni (type K)
Measuring range MB	
MB 1	: -50..+200 °C
MB 2	: -50..+250 °C
MB 3	: -50..+400 °C
Probe diameter D	: 3 mm, 4 mm, 5 mm, 6 mm, 8 mm other diameters upon request
Fitting length EL	: 50 mm, 100 mm (standard), 150 mm, 250 mm, 500 mm, 1000 mm, 1500 mm other fitting lengths possible
Accuracy	: class 1
Tube material	: V4A
Cable	: 1 m silicone compensation line (std), loose ends
Silicone cable	: up to max. 200 °C (standard)
Teflon cable	: up to max. 250 °C
Glass silk cable	: up to max. 400 °C

Dimensions

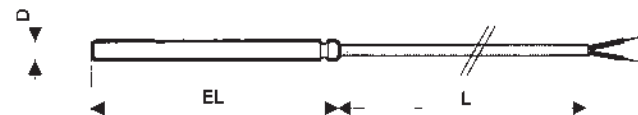

Ordering code

GTF101K-OKH - 1. - 2. - 3. - 4. - 5.

1. Measuring range	
MB1	-50..+200 °C
MB2	-50..+250 °C <i>only with Teflon or glass silk cable</i>
MB3	-50..+400 °C <i>only with glass silk cable</i>
2. Probe diameter D	
D30	3.0 mm <i>only with Teflon cable</i>
D40	4.0 mm <i>only with Teflon cable</i>
D50	5.0 mm
D60	6.0 mm
D80	8.0 mm
Dxx	other Ø in mm (upon request)
3. Fitting length EL	
0150	150 mm
0250	250 mm
0500	500 mm
1000	1000 mm
1500	1500 mm
xxxx	any EL in mm (e.g.: 0100 = 100 mm)
4. Cable length L	
L01	1 m (standard)
Lxx	desired length in m (e.g. L03 = 3 m)
5. Cable material	
S	silicone cable up to max. 200 °C (standard)
T	Teflon cable up to max. 250 °C
G	glass silk cable up to max. 400 °C

Temperature Sensor 7132



Characteristics

- Thermocouple Fe-CuNi (type J); NiCr-Ni (type K)
- RTD Pt100, class B
- Protective tube stainless steel 1.4571 perforated
- Measuring tip plane
- Cable type flexible fiberglass insulation with steel wire braiding or Teflon-Silicon-insulation

Dimensions

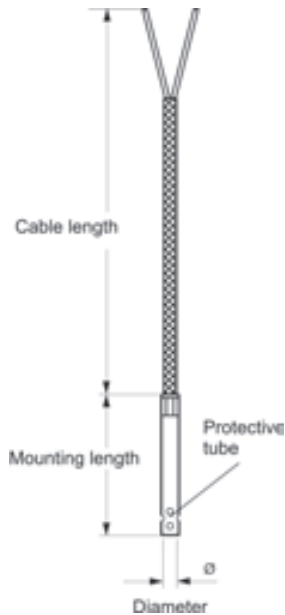

Accessories

Description
Displacement adapter G 1/8
incl. nut suitable for
protective tube diameter 5 mm

Ordering code
SV1805

Ordering code

1. 2. 3. 4. 5. 6. 7. 8. 9.
□ - □ - □ - □ - □ - □ - □ - □ - □

1. Measuring element	7132	Pt100 class B
2. Number of elements	1	
3. Connection type	2L	2-wire
4. Probe diameter	5	5 mm
5. Fitting length EL	50	50 mm
	100	100 mm
	xx	custom length; specify the length in mm in the plain text
6. Cable length (please state in clear text)	2000	Cable length in mm standard
	XXXX	custom length in mm; price/m
7. Operating temperature	400°C	Fiberglass insulation

Stock

7132-1-2L-5-50-2000-400°C
7132-1-2L-5-100-2000-400°C

Temperature Sensor 7024 / 7124



Characteristics

- Thermocouple Fe-CuNi (type J); NiCr-Ni (type K)
- RTD Pt100, class B
- Thermowell material stainless steel 1.4571
- Measuring tip plane or angle 120°
- Cable type flexible fiberglass insulation with steel wire braiding or Teflon-Silicon-insulation

Dimensions

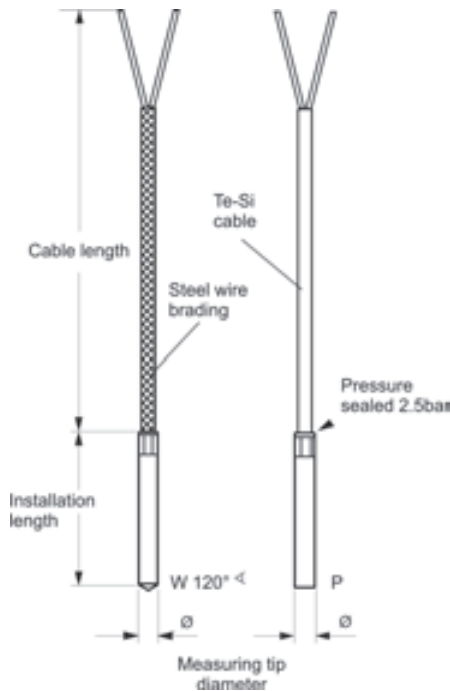

Ordering code

1. 2. 3. 4. 5. 6. 7. 8. 9.
 - - - - - - - - -

1. Measuring element	
7024/J	thermocouple Fe-CuNi (type J)
7024/K	thermocouple NiCr-Ni (type K)
7124	Pt100 class B
2. Number of elements	
1	
2	
3. Connection type	
2L	2-wire
3L	3-wire (only 7124, Pt100)
4L	4-wire (only 7124, Pt100)
4. Measuring tip diameter	
3	3 mm
4	4 mm
5	5 mm
6	6 mm
5. Measuring tip type	
P	plane (flat tip)
W	angle 120°
6. Installation length	
30	30 mm
40	40 mm
60	60 mm
xx	custom length [mm]
7. Cable type insulation	
EGL	flexible fiberglass with steel wire braiding
8. Cable length (please state in clear text)	
X	length in mm
9. Operating temperature	
180°C	Teflon-Silicon-insulation
400°C	Fiberglass insulation

(other versions on request)

Stock

7024/J-1-2L-3-P-30-EGL-2000-400°C
 7024/J-1-2L-4-W-40-EGL-2000-400°C
 7024/J-1-2L-6-W-60-EGL-2000-400°C
 7124-1-2L-4-W-40-EGL-2000-400°C
 7124-1-2L-6-P-60-EGL-2000-400°C
 7124-1-2L-6-P-60-Te-Si-3000-180°C

Temperature Sensor 7012 / 7112



Characteristics

- Thermocouple Fe-CuNi (type J); NiCr-Ni (type K)
- RTD Pt100, class B
- Thermowell material stainless steel 1.4571
- Measuring tip plane or angle 120°
- Cable type flexible fiberglass insulation with steel wire braiding or Teflon-Silicon-insulation

Dimensions

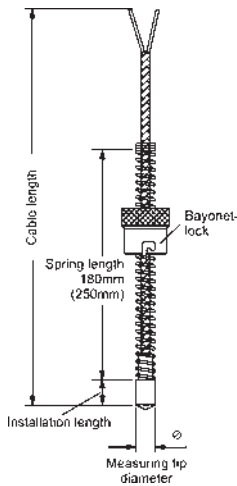

Accessories

Description

- Thread adapter M10x1
- Thread adapter M12x1
- Thread adapter M12x1.75

Ordering code

- GN-40
- GN-41
- GN-49 (standard)

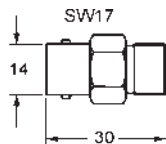

- Thermowell R ¼ 30 mm length
- Thermowell R ¼ 100 mm length

- THR ¼ -SW17
- THR ¼ -SW17-100

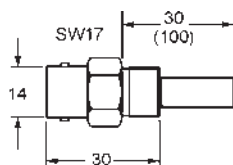

Ordering code

1. 2. 3. 4. 5. 6. 7. 8. 9. 10. 11.
 - - - - - - - - - - -

| | |
|--|--|
| 1. Measuring element | |
| 7012/J | thermocouple Fe-CuNi (type J) |
| 7012/K | thermocouple NiCr-Ni (type K) |
| 7112 | Pt100 class B |
| 2. Number of elements | |
| 1 | |
| 2 | |
| 3. Connection type | |
| 2L | 2-wire |
| 3L | 3-wire (only 7112, Pt100) |
| 4L | 4-wire (only 7112, Pt100) |
| 4. Measuring tip diameter | |
| 6 | 6 mm |
| 8 | 8 mm |
| 5. Measuring tip type | |
| P | plane (flat tip) |
| W | angle 120° |
| 6. Installation length | |
| 15 | 15mm |
| 7. Spring length | |
| - | without |
| 180 | 180mm |
| 250 | 250mm |
| 8. Bayonet lock type | |
| VK14 | inner diameter 12.2mm |
| VK17 | inner diameter 14.5mm |
| 9. Cable type insulation | |
| EGL | flexible fiberglass with steel wire braiding |
| Te-Si | Teflon-Silicon up to 180°C |
| 10. Cable length (please state in clear text) | |
| X | length in mm |
| 11. Operating temperature | |
| 180°C | Teflon-Silicon-insulation |
| 400°C | Fiberglass insulation |

(other versions on request)

Stock

- 7012/J-1-2L-6-W-15-180-VK17-EGL-2000-400°C
- 7012/J-1-2L-8-W-15-180-VK17-EGL-2000-400°C
- 7112-1-2L-6-P-15-180-VK17-EGL-2000-400°C
- 7112-1-2L-6-W-15-180-VK17-EGL-2000-400°C
- 7112-1-2L-8-P-15-180-VK17-EGL-2000-400°C
- 7112-1-2L-8-W-15-180-VK17-EGL-2000-400°C
- 7112-2-2L-6-W-15-180-VK17-EGL-2000-400°C
- 7112-2-2L-8-W-15-180-VK17-EGL-2000-400°C

Penetration Probe GES 21



- Core temperature / food probe
- With Teflon handle and Teflon cable, up to 250 °C

Characteristics

The GES 21 is a penetration probe with slim insertion tip and is suitable for core temperature measurements in foods or other soft and plastic media. The GES 21 can be used in canteen kitchens, bakeries, butcher's shops etc. Both handle and cable are made of Teflon and can resist air temperatures up to 250 °C.

The measurement is done by means of a resistive temperature sensor (Pt100 / Pt 1000) or thermocouple (NiCr-Ni).

The probe is delivered with 1 m Teflon cable with loose ends and end sleeves for universal appliance.

Technical data

| | |
|------------------|---|
| Sensor element | : Pt100 (2-wire)
Pt1000 (2-wire)
NiCr-Ni |
| Measuring range | : -200..+250 °C |
| Accuracy | |
| Pt100 / Pt1000 | : DIN class B |
| NiCr-Ni | : class 1 |
| Probe material | : V4A-tube |
| Handle | : Teflon (up to 250 °C) |
| Connection cable | : 1m Teflon cable (up to 250 °C)
with stainless steel kink protection,
loose ends |

Dimensions

| | |
|----------------|--------|
| Probe diameter | Ø 3 mm |
| Probe length | 100 mm |
| Handle | 70 mm |



Ordering code

GES21 - 1. - 2.

| | |
|--------------------------|--------------------------------------|
| 1. Sensor element | |
| P | Pt100 (2-wire) |
| T | Pt1000 (2-wire) |
| K | NiCr-Ni |
| 2. Cable length L | |
| L01 | 1 m (standard) |
| Lxx | desired length in m (e.g. L04 = 4 m) |

Screw-In Probe GTF 102



- Pt100, Pt1000, NiCr-Ni (type K)
- with thread and cable (loose ends)
- Very robust

Characteristics

The GTF 102 is a temperature probe modified completely according to customer specifications. The GTF 102 is very robust and therefore especially suited for application at high permanent temperatures in air, gases liquids or aggressive environments.

The measurement is done by means of a resistive temperature sensor (Pt100 / Pt 1000) or thermocouple (type K, NiCr-Ni).

The probe is delivered with thread, cable sleeve and 1 m silicone cable (compensation line with loose ends) by default.

Technical data

| | |
|------------------------|---|
| Sensor element | : Pt100 (2- / 3- or 4-wire)
Pt1000 (2-wire)
NiCr-Ni |
| Measuring range | |
| NiCr-Ni | : -200..+1000 °C |
| Pt100 / Pt1000 | : -50..+400 °C |
| Accuracy | : Pt100 / Pt1000: DIN class B
NiCr-Ni: class 1 |
| Tube material | : V4A |
| Thread material | : stainless steel |
| Connection cable | : standard: silicone compensation line,
loose ends, length: 1 m long
(up to max. 200) |

Dimensions

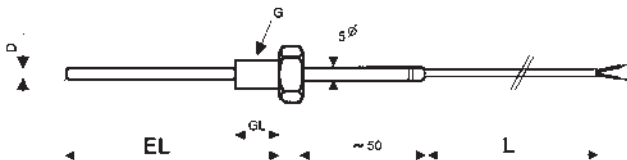

Ordering code

GTF102 - 1. - 2. - 3. - 4. - 5. - 6. - 7. - 8.

| | | |
|-------------------------------------|---|---|
| 1. Sensor element | | |
| P2 | Pt100 (2-wire) | |
| P3 | Pt100 (3-wire) | |
| P4 | Pt100 (4-wire) | |
| T2 | Pt1000 (2-wire) | |
| K | NiCr-Ni | |
| 2. Accuracy | | |
| 1 | class 1 | <i>only NiCr-Ni</i> |
| A | DIN class A | <i>only Pt100 / Pt1000</i> |
| B | DIN class B (Standard) | <i>only Pt100 / Pt1000</i> |
| D | 1/3 DIN class B | <i>only Pt100 / Pt1000</i> |
| Z | 1/10 DIN class B | <i>only Pt100</i> |
| 3. Measuring range MB | | |
| MB0 | standard measuring range | |
| MBX | other measuring range upon request | |
| 4. Probe diameter D | | |
| 22 | 2.2 mm | <i>only with sensor element NiCr-Ni (K)</i> |
| 30 | 3.0 mm (standard) | |
| 40 | 4.0 mm | |
| 50 | 5.0 mm | |
| 60 | 6.0 mm | |
| 80 | 8.0 mm | |
| 5. Fitting length EL (±10mm) | | |
| 0100 | 100 mm (standard) | |
| 0150 | 150 mm | |
| 0250 | 250 mm | |
| 0500 | 500 mm | |
| 1000 | 1000 mm | |
| 1500 | 1500 mm | |
| xxxx | any EL in mm (e.g.: 0700 = 700 mm) | |
| 6. Thread | | |
| G1 | G ½ (standard) | |
| G2 | G ¼ | |
| G3 | G ¾ | |
| G5 | G ⅝ | |
| M5 | M5 | |
| M6 | M6 | |
| M8 | M8 | |
| M0 | M10 | |
| M2 | M12 | |
| M4 | M14 | |
| 7. Cable length L | | |
| L01 | 1 m (standard) | |
| Lxx | desired length in m (e.g. L03 = 3 m) | |
| 8. Cable material | | |
| P | PVC cable up to max. 105 °C | |
| S | silicone cable up to max. 200 °C (standard) | |
| T | Teflon cable up to max. 250 °C | |
| G | glass silk cable up to max. 400 °C | |

Temperature Sensor 8100/A, 8100/C



Characteristics

- Thermocouple Fe-CuNi (type J); NiCr-Ni (type K)
- RTD Pt100/Pt1000 class B,
- Protective tube, stainless steel 1.4571
- Connection head form BK/PK, DIN 43729, IP65
- Head transmitter optional

Dimensions

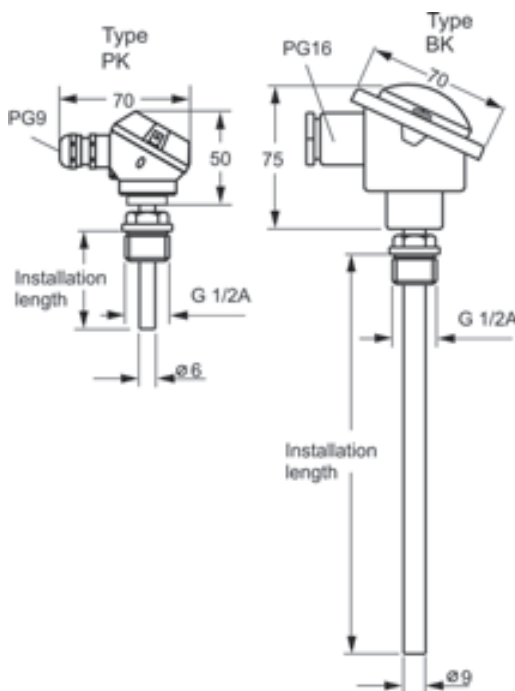

Ordering code

1. 2. 3. 4. 5. 6. 7. 8. 9. 10.
 - - - - - - - - - -

| | |
|------------------------------------|---|
| 1. Measuring element | |
| 8100/A | Pt100 class B |
| 8100/C | Pt1000 class B |
| 2. Number of elements | |
| 1 | 1 measuring element |
| 2 | 2 measuring elements |
| 3. Connection type | |
| 2L | 2-wire (as 3- and 4-wire applicable) |
| 4. Measuring tip diameter | |
| 6 | 6 mm |
| 8 | 8 mm |
| 9 | 9 mm |
| 5. Installation length [mm] | |
| 40 | 40 mm |
| 100 | 100 mm |
| 160 | 160 mm |
| 250 | 250 mm |
| 400 | 400 mm |
| 600 | 600 mm |
| xx | custom length; specify the length in the plain text |
| 6. Neck pipe length [mm] | |
| 0 | without |
| 50 | 50 mm |
| 100 | 100 mm |
| xx | custom length; specify the length in the plain text |
| 7. Process connection | |
| G 1/2 | fixed gland 1/2 " |
| G 3/4 | fixed gland 3/4 " |
| G1 | fixed gland 1" |
| 8. Connection head | |
| PK | form P (miniature head) IP65 |
| BK | form B (standard) IP65 |
| 9. Operating temperature | |
| 300 or rather 6mm | 300 °C |
| 400 °C | 6mm > 400 °C |
| 10. Options | |
| 00 | without option |
| T4 | integrated head transmitter 4..20mA (only head BK) |

Stock

8100/A-1-6-40-0-G1/2-PK-300°C
 8100/A-1-9-100-0-G1/2-BK-400°C
 8100/A-1-9-160-0-G1/2-BK-400°C
 8100/A-1-9-250-0-G1/2-BK-400°C
 8100/A-1-9-400-0-G1/2-BK-400°C
 8100/A-1-9-600-0-G1/2-BK-400°C
 8100/A-2-9-100-0-G1/2-BK-400°C
 8100/A-2-9-160-0-G1/2-BK-400°C
 8100/A-2-9-250-0-G1/2-BK-400°C
 8100/C-1-6-40-0-G1/2-PK-300°C
 8100/C-1-6-80-0-G1/2-PK-300°C

Temperature Sensor 8101/A



Characteristics

- Thermocouple Fe-CuNi (type J); NiCr-Ni (type K)
- RTD Pt100/Pt1000 class B,
- Protective tube, stainless steel 1.4571
- Connection head form BK/PK, DIN 43729, IP65
- Head transmitter optional

Dimensions



Ordering code

1. 2. 3. 4. 5. 6. 7. 8. 9. 10.
 - - - - - - - - - -

| | | |
|----------------------------------|--------|---|
| 1. Measuring element | 8101/A | Pt100 class B |
| 2. Number of elements | 1 | 1 measuring element |
| | 2 | 2 measuring elements |
| 3. Connection type | 2L | 2-wire (as 3- and 4-wire applicable) |
| 4. Measuring tip diameter | 9/6 | Ø 9mm, sensor tip 40mm reduced to Ø 6mm |
| 5. Fitting length (mm) | 40 | 40 mm |
| | 100 | 100 mm |
| | 160 | 160 mm |
| | 250 | 250 mm |
| | 400 | 400 mm |
| | 600 | 600 mm |
| | xx | custom length; specify the length in the plain text |
| 6. Neck pipe length (mm) | 0 | without |
| | 50 | 50 mm |
| | 100 | 100 mm |
| | xx | custom length; specify the length in the plain text |
| 7. Process connection | G ½ | fixed gland ½ " |
| | G ¾ | fixed gland ¾ " |
| | G1 | fixed gland 1" |
| 8. Connection head | PK | form P (miniature head) IP65 |
| | BK | form B (standard) IP65 |
| 9. Operating temperature | 400 °C | |
| 10. Options | 00 | without option |
| | T4 | integrated head transmitter 4...20mA (only head BK) |

Stock

- 8101/A-1-9/6-160-0-G1/2A-BK-500 °C
- 8101/A-1-9/6-250-0-G1/2A-BK-500 °C
- 8101/A-1-9/6-400-0-G1/2A-BK-500 °C
- 8101/A-1-9/6-600-0-G1/2A-BK-500 °C
- 8101/A-2-9/6-160-0-G1/2A-BK-500 °C

Duct Temperature Sensor 8105



Characteristics

- RTD Pt100 Kl. B, fast response, 2-wire; usable as 3-wire sensor
- Protective tube $\varnothing 4$ mm, stainless steel 1.4571
- Connection head form P, DIN 43729, IP65
- Flange mounting

Dimensions

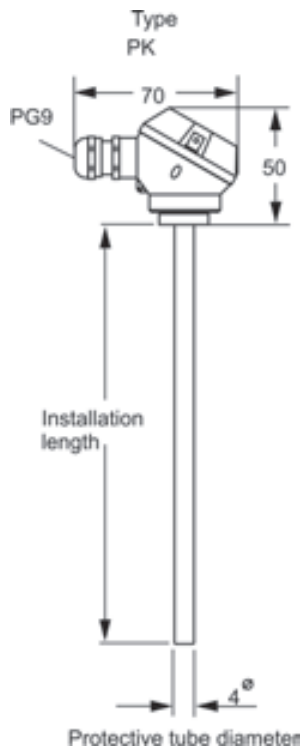

Accessories

Description
Mounting flange

Ordering code
MF4

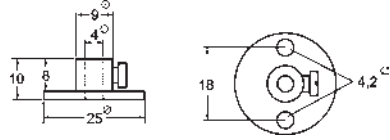

Ordering code

1. 2. 3. 4. 5. 6. 7. 8.
 - - - - - - - |

| | | |
|---------------------------------|-------|---|
| 1. Measuring element | 8105 | Pt100 class B |
| 2. Number of elements | 1 | 1 measuring element |
| | 2 | 2 measuring elements |
| 3. Connection type | 2L | 2-wire (as 3- and 4-wire applicable) |
| 4. Sensor diameter | 4 | 4 mm |
| 5. Fitting length [mm] | 140 | 140 mm |
| | 300 | 300 mm |
| | xx | custom length; specify the length in the plain text |
| 6. Connection head | PK | form P (miniature head) IP65 |
| | BK | form B (standard) IP65 |
| 7. Operating temperature | 250°C | |
| 8. Options | 00 | without option |
| | T4 | integrated head transmitter 4...20mA (only head BK) |
| Accessories | | |
| | MF4 | Mounting flange |

Stock

8105-1-4-140-PK-250°C
8105-1-4-300-PK-250°C

Ex Temperature Probe GTF 101-Ex

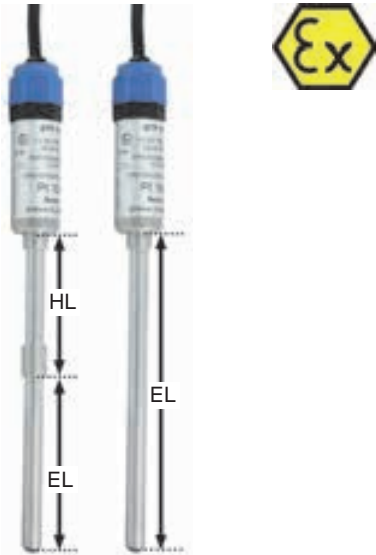

- For use in potentially explosive gaseous or dust mixtures
- Potential-free temperature probe made of stainless steel
- Assembled according to customer preferences

Characteristics

The temperature probe GTF 101-Ex is a mounting probe for usage in potentially explosive atmospheres. The modular build up ensures greatest flexibility and the possibility to fit it to the existing conditions. Therefore parameters like length, diameter, cable or type of protection ("i" or "e") can be adjusted.

There are 2 different sensor types available for the measuring unit of GTF 101-Ex: resistance thermometer Pt100, Pt1000 or thermocouple type K, type N (standard). Only sheathed resistance thermometer or sheathed thermocouple are used.

The probes can be customized according to customer requirements.

Technical data

Sensor element : Pt100, Pt1000 (sheathed element), 4-wire;
type K (NiCr-Ni) or type N (NiCrSi-NiSi) sheathed thermocouple

Measuring range
Pt100 / Pt1000 : -200..+100 °C (600 °C with neck tube)
Type K / type N : -200..+100 °C (900 °C with neck tube)

Accuracy
Pt100 / Pt1000 : DIN class B
Type K / type N : class 1
Type of protection : "i" intrinsic safe
"e" increased safety

Ambient temperature : -20..+60 °C (protection type "e")
-20..+80 °C (protection type "i")

| | |
|--|---|
| Process connection | no process connection |
| Length of neck tube | no neck tube (for T ≤ 100 °C)
with neck tube (for T >100 °C) |
| Electrical connection | silicone cable, standard length 1m |
| Mounting | by separate clamping ring screw connection |
| Suitable for potentially explosive atmospheres | zone1, zone 2, zone 21, zone 22 |

Dimensions

Head / capsule Ø = approx. 15 mm, L = approx. 53 mm

Ordering code

GTF101-Ex - - - - - - - - - - -

| | |
|---|--|
| 1. Sensor element | |
| P | Pt100 |
| S | Pt1000 |
| T | thermocouple type K |
| U | thermocouple type N |
| 2. Neck tube | |
| K | no neck tube (for T ≤ 100 °C) |
| M | with neck tube (for T >100 °C) |
| 3. Ambient temperature | |
| A | standard range -20..+60 °C |
| H | higher ambient temperature -20..+80 °C
(only available in combination with protection type "i") |
| 4. Length of neck tube HL | |
| xxx | length in mm (e.g. 050 = 50 mm) |
| 5. Probe diameter D | |
| Dx | Ø 3 mm, 4 mm, 5 mm, 6 mm, 8 mm
(e.g. 8 = 8 mm)
Note:
Ø 3 mm only for Pt100 / Pt1000 possible.
• the min. length is then 60 mm.
• the probe tip is Ø 3 mm (for first approx. 30 mm) and then Ø = 6 mm |
| 6. Fitting length EL | |
| xxxx | length in mm (e.g. 0100 = 100 mm) |
| 7. Cable length (4-wire) | |
| x | length in m (e.g. 1 = 1 m) |
| 8. Type of protection | |
| e | increased safety due to potting of encapsulation |
| i | intrinsic safe |
| 9. Potentially explosive atmospheres | |
| 01 | gaseous mixture, zone 1 |
| 02 | gaseous mixture, zone 2 |
| 21 | dust, zone 21 |
| 22 | dust, zone 22 |
| 10. Measuring range | |
| xxx | desired measuring range (e.g. -50..+100 °C) |

Ex temperature probe GTF 102-Ex



| | |
|--|---|
| Length of neck tube | no neck tube (for $T \leq 100\text{ °C}$)
with neck tube (for $T > 100\text{ °C}$) |
| Electrical connection | silicone cable, standard length 1m |
| Mounting | by process connection |
| Suitable for potentially explosive atmospheres | zone 0/1, zone 1, zone 2, zone 20/21
zone 21, zone 22 |

Dimensions

| | |
|----------------|---|
| Head / capsule | $\varnothing = \text{approx. } 15\text{ mm}$, $L = \text{approx. } 53\text{ mm}$ |
|----------------|---|

- For use in potentially explosive gaseous or dust mixtures
- Potential-free temperature probe made of stainless steel
- Assembled according to customer preferences

Characteristics

The screw-in temperature probe GTF 102-Ex is a mounting probe for usage in potentially explosive atmospheres. The modular build up ensures greatest flexibility and the possibility to fit it to the existing conditions. Therefore parameters like length, diameter, cable or type of protection ("i" or "e") can be adjusted.

There are 2 different sensor types available for the measuring unit of GTF 102-Ex: resistance thermometer Pt100, Pt1000 or thermocouple type K, type N (standard). Only sheathed resistance thermometer or sheathed thermocouple are used.

The probes can be customized according to customer requirements.

Technical data

Sensor element : Pt100, PT1000 (sheathed element),
4-wire;
type K (NiCr-Ni) or type N (NiCrSi-NiSi)
sheathed thermocouple

Measuring range

Pt100 / Pt1000 : $-200..+100\text{ °C}$ (600 °C with neck tube)
Type K / type N : $-200..+100\text{ °C}$ (900 °C with neck tube)

Accuracy

Pt100 / Pt1000 : DIN class B
Type K / type N : class 1
Type of protection : "i" intrinsic safe
"e" increased safety

Ambient temperature : $-20..+60\text{ °C}$ (protection type "e")
 $-20..+80\text{ °C}$ (protection type "i")

continued on next page

| | |
|--------------------|------------------------------|
| Process connection | cylindrical or metric thread |
|--------------------|------------------------------|

Ordering code

GTF102-Ex 1. - 2. - 3. - 4. - 5. - 6. - 7. - 8. - 9. - 10. - 11. - 12.

| | |
|--|--|
| 1. Sensor element | |
| P | Pt100 |
| S | Pt1000 |
| T | thermocouple type K |
| U | thermocouple type N |
| 2. Neck tube | |
| K | no neck tube (for T ≤ 100 °C) |
| M | with neck tube (fr T >100 °C) |
| 3. Ambient temperature | |
| A | standard range -20..+60 °C |
| H | higher ambient temperature -20..+80 °C
(only available in combination with protection type "I") |
| 4. Type of process connection | |
| 1 | G-thread (cylindrical thread) |
| 2 | M-thread (metric thread) |
| 5. Size of process connection | |
| 1 | 1/8 (for G-thread) <i>not possible for zone 0/1 and zone 20/21</i> |
| 2 | 1/4 (for G-thread) <i>not possible for zone 0/1 and zone 20/21</i> |
| 3 | 3/8 (for G-thread) |
| 4 | 1/2 (for G-thread) |
| 5 | 3/4 (for G-thread) |
| 6 | 8x1 (for M-thread) <i>not possible for zone 0/1 and zone 20/21</i> |
| 7 | 10x1 (for M-thread) <i>not possible for zone 0/1 and zone 20/21</i> |
| 8 | 14x1 (for M-thread) <i>not possible for zone 0/1 and zone 20/21</i> |
| 6. Length of neck tube HL | |
| xxx | length in mm (e.g. 050 = 50 mm) |
| 7. Probe diameter Ø | |
| x | 3 mm, 4 mm, 5 mm, 6 mm, 8 mm
(e.g. 8 = 8 mm)
Note:
<ul style="list-style-type: none"> • Ø 3 mm only for Pt100 / Pt1000 possible • the min. length is then 60 mm • the probe tip is Ø 3 mm (for first approx. 30 mm) and then Ø = 6 mm • for zone 0/1, 20/21 only Ø 6/8 mm possible |
| 8. Fitting length EL | |
| xxxx | length in mm (e.g. 0100 = 100 mm) |
| 9. Cable length (4-wire) | |
| x | length in m (e.g. 1 = 1 m) |
| 10. Type of protection | |
| e | increased safety due to potting of encapsulation
(only permissible for zone 1 and 2 or zone 21 and 22) |
| i | intrinsic safe |
| 11. Potentially explosive atmospheres | |
| 00 | gaseous mixture, zone 0/1
(sensor tube in zone 0 / cable sleeve in zone 1) |
| 01 | gaseous mixture, zone 1 |
| 02 | gaseous mixture, zone 2 |
| 20 | dust, zone 20/21
(sensor tube in zone 20 / cable sleeve in zone 21) |
| 21 | dust, zone 21 |
| 22 | dust, zone 22 |
| 12. Measuring range | |
| xxx | desired measuring range (e.g. -50..+100 °C) |

Ex temperature probe GTF 103-Ex



- For use in potentially explosive gaseous or dust mixtures
- Potential-free temperature probe made of stainless steel
- Assembled according to customer preferences

Characteristics

The DIN-B-head temperature probe GTF 103-Ex is a mounting probe for usage in potentially explosive atmospheres. The modular build up ensures greatest flexibility and the possibility to fit it to the existing conditions. Therefore parameters like length, diameter, cable or type of protection (“i” or “e”) can be adjusted.

There are 2 different sensor types available for the measuring unit of GTF 103-Ex: resistance thermometer Pt100, Pt1000 or thermocouple type K, type N (standard). Only sheathed resistance thermometer or sheathed thermocouple are used.

The probe has a DIN-B-head with clamp socket allowing the comfortable connection of your own connection cable. The probes can be customized according to customer requirements. The measuring units of the GTF 103-Ex series (with the exception of D = 3 mm) are exchangeable. The GTF 103-Ex is also available with integrated transmitter.

Technical data

Sensor element : Pt100, PT1000 (sheathed element), 4-wire; type K (NiCr-Ni) or type N (NiCrSi-NiSi) sheathed thermocouple

Measuring range

Pt100 / Pt1000 : -200..+100 °C (600 °C with neck tube)
Type K / type N : -200..+100 °C (900 °C with neck tube)

Accuracy

Pt100 / Pt1000 : DIN class B
Type K / type N : class 1

Type of protection : “i” intrinsic safe
“e” increased safety
Ambient temperature : -20..+60 °C (protection type “e”)
-20..+80 °C (protection type “i”)

| | |
|--|--|
| Process connection | cylindrical or metric thread or without thread |
| Length of neck tube | no neck tube (for T ≤ 100 °C)
with neck tube (for T >100 °C) |
| Electrical connection | cable entry via pressure screw |
| Mounting | by process connection or by separate clamping ring screw connection |
| Suitable for potentially explosive atmospheres | zone 0, zone 0/1, zone 1, zone 2,
zone 20 zone 20/21 zone 21, zone 22 |

Options

The GTF 103-Ex is optionally available with GITT 01-Ex, output signal 4..20 mA, custom-made measuring range. Useable only in protection type “i”.

Dimensions

| | |
|----------------|--|
| Head / capsule | Ø = approx. 63 mm, L = approx. 117 mm, H = approx. 78 mm |
|----------------|--|

continued on next page

Ordering code

GTF103-Ex - - - - - - -
 1. 2. 3. 4. 5. 6. 7.
 8. 9. 10. 11. 12. 13.
 - - - - - -

| | | |
|--------------------------------------|--|---|
| 1. Standard signal | | |
| O | without output signal | |
| G | with output signal 4..20 mA (GITT 01-Ex) | |
| 2. Sensor element | | |
| P | Pt100 | |
| S | Pt1000 | |
| T | thermocouple type K | |
| U | thermocouple type N | |
| 3. Process connection | | |
| J | with process connection | |
| N | without process connection
(only for zone 1, 2, 21, 22) | |
| 4. Neck tube | | |
| K | no neck tube (for T ≤ 100 °C) | |
| M | with neck tube (for T >100 °C) | |
| 5. Ambient temperature | | |
| A | standard range | |
| | zone 0, 20 | -20..+40 °C |
| | zone 0/1, 1, 2, 21, 22 | -20..+50 °C (with output signal) |
| H | higher ambient temperature | |
| | zone 0, 20 | -20..+60 °C |
| | zone 0/1, 1, 2, 21, 22 | -20..+80 °C (only in combination with protection type "i", only possible for types without output signal) |
| 6. Type of process connection | | |
| 0 | without thread | |
| 1 | G-thread (cylindrical thread) | |
| 2 | M-thread (metric thread) | |
| 7. Size of process connection | | |
| 0 | kein Gewinde | |
| 1 | 1/8 (for G-thread) | <i>not possible for zone 0, 0/1, 20, 20/21</i> |
| 2 | 1/4 (for G-thread) | <i>not possible for zone 0, 0/1, 20, 20/21</i> |
| 3 | 3/8 (for G-thread) | |
| 4 | 1/2 (for G-thread) | |
| 5 | 3/4 (for G-thread) | |
| 6 | 8x1 (for M-thread) | |
| 7 | 10x1 (for M-thread) | <i>not possible for zone 0, 0/1, 20, 20/21</i> |
| 8 | 14x1 (for M-thread) | |
| 8. Length of neck tube HL | | |
| xxx | length in mm (e.g. 050 = 50 mm) | |
| 9. Probe diameter Ø | | |
| x | 3 mm, 4 mm, 5 mm, 6 mm, 8 mm
(e.g. 8 = 8 mm)
Note:
<ul style="list-style-type: none"> • Ø 3 mm only for Pt100 / Pt1000 possible <ul style="list-style-type: none"> • the min. length is then 60 mm • the probe tip is Ø 3 mm (for first approx. 30 mm) and then Ø = 6 mm • for zone 0, 0/1, 20/21 only Ø 6/8mm possible | |

| | |
|--|---|
| 10. Fitting length EL | |
| xxxx | length in mm (e.g. 0100 = 100 mm) |
| 11. Type of protection | |
| e | increased safety due to potting of encapsulation
(only permissible for zone 1 and 2 or zone 21 and 22) |
| i | intrinsic safe |
| 12. Potentially explosive atmospheres | |
| 00 | gaseous mixture, Zone 0 |
| 0A | gaseous mixture, Zone 0/1
(sensor tube in zone 0 / head in zone 1) |
| 01 | gaseous mixture, Zone 1 |
| 02 | gaseous mixture, Zone 2 |
| 20 | dust, Zone 20 |
| 2A | dust, Zone 20/21
(sensor tube in zone 20 / head in zone 21) |
| 21 | dust, Zone 21 |
| 22 | dust, Zone 22 |
| 13. Measuring range | |
| xxx | desired measuring range (e.g. -50..+100 °C) |

Safety Thermocouple Sensor TC293



Dimensions

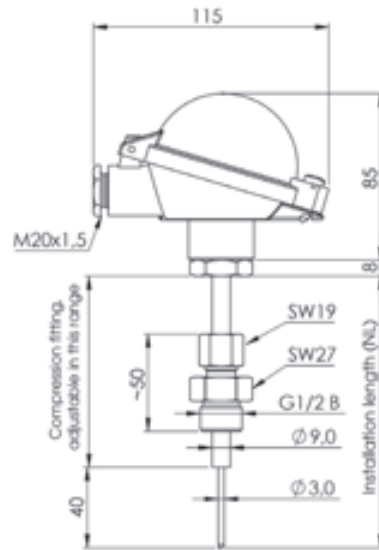

Characteristics

- Fast response sensor for measurement in exhaust gas and air
- Certified as Sensor for Safety Temperature Limiters STL50 for gaseous media acc. to SIL 2 (DIN EN 61508) and DIN EN 14597 (substitute DIN 3440)
- Ex certified to ATEX Ex-i GD for gases and dust
- Sensor with 2 x thermocouples J, K or N, isolated
- Max. operating temperature depends to the thermocouple
- Process pressure 25 bar
- Protection tube D = 9/3 mm, Inconel 600 W-No. 2.4816
- Process connection clamp gland G 1/2 B
- Terminal head BSZ (Aluminum) IP65 with snap-lid

Temperature equalization

The 63.2 % step-response time of temperature variation at the probe tip will be:

Medium T63.2%
Exhaust typical 20 s
Air typical 22 s

Ordering code

1. 2. 3. 4. 5. 6. 7. 8.
□ - □ - □ - □ - □ - □ - □ - □

| | |
|--------------------------------------|--|
| 1. Type | TC293 |
| 2. Variation | 00 Standard
Ex Ex certified acc. to ATEX Ex-i GD |
| 3. Double-thermocouple | 2J type J (Fe-CuNi)
operating temperature -100..+600 °C
cable color black(+), white(-)
2K type K (NiCr-Ni)
operating temperature -100..+900 °C
cable color green(+), white(-)
2N type N (NiCrSi-NiSi)
operating temperature -100..+1000 °C
cable color pink(+), white(-) |
| 4. Protection tube diameter | 9/3 9mm to 3mm reduced |
| 5. Installation length NL | 100 100 mm
160 160 mm
250 250 mm
400 400 mm
600 600 mm
XX custom length |
| 6. Process connection | KV 1/2 B clamping sleeve slide-able 1/2 " |
| 7. Terminal head | BSZ with snap-lid (Aluminum) |
| 8. Max. operating temperature | see thermocouple type |

(Custom variation on request)

Safety RTD Sensor TR293



Characteristics

- Fast response sensor for measurement in exhaust gas and air
- Certified as Sensor for Safety Temperature Limiters STL50 for gaseous media acc. to SIL 2 (DIN EN 61508) and DIN EN 14597 (substitute DIN 3440)
- Ex certified to ATEX Ex-i GD for gases and dust
- Sensor with 2 x Pt100 class A, 3-wire
- Max. operating temperature -100..+600 °C
- Process pressure 25 bar
- Protection tube D = 9/3 mm, stainless steel 1.4571
- Process connection clamp gland G 1/2 B
- Terminal head BSZ (Aluminum) IP65 with snap-lid

Temperature equalization

The 63.2 % step-response time of temperature variation at the probe tip will be:

Medium T63.2%
Exhaust typical 20 s
Air typical 22 s

Dimensions

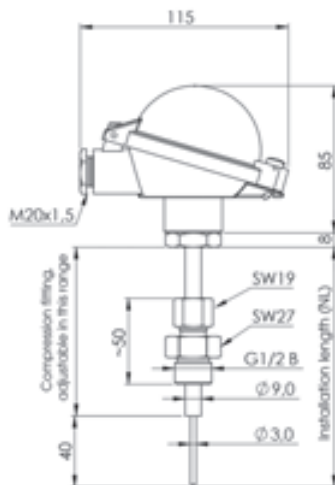

Connection diagram

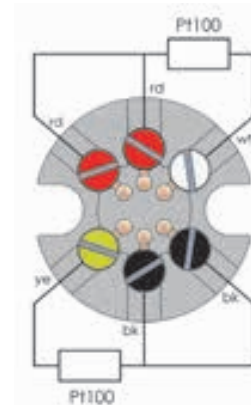

Ordering code

1. 2. 3. 4. 5. 6. 7. 8.
□ - □ - □ - □ - □ - □ - □ - □

| | |
|--------------------------------------|--|
| 1. Type | TR293 |
| 2. Variation | 00 standard
Ex Ex certified acc. to ATEX Ex-i GD |
| 3. Measuring elements | 2 2 elements Pt100 class A, 3-wire |
| 4. Protection tube diameter | 9/3 9mm to 3mm reduced |
| 5. Installation length NL | 100 100 mm
160 160 mm
250 250 mm
400 400 mm
600 600 mm
XX custom length |
| 6. Process connection | KV 1/2 B clamp gland, slide-able 1/2 " |
| 7. Terminal head | BSZ with snap-lid (Aluminum) |
| 8. Max. operating temperature | 600°C |

(Custom variation on request)

Safety Thermocouple Sensor TC296



Dimensions

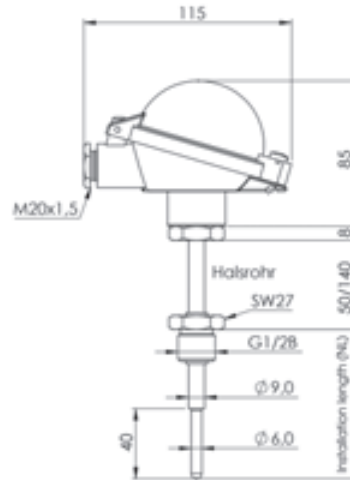

Characteristics

- Fast response sensor for measurement in water, oil and air
- Certified as Sensor for Safety Temperature Limiters STL50 (exhaust gas excluded), acc. to DIN EN 14597 (substitute DIN 3440)
- Ex certified to ATEX Ex-i GD for gases and dust
- Sensor with 2 x thermocouples J, K or N, isolated and replaceable
- Max. operating temperature depends to the thermocouple
- Process pressure 40 bar
- Protection tube D = 9/6mm, Inconel 600 W-No. 2.4816
- Process connection G 1/2 B
- Terminal head BSZ (Aluminum) IP65 with snap-lid

Temperature equalization

The 63.2 % step-response time of temperature variation at the probe tip will be:

| Medium | T63.2% |
|--------|--------------|
| Water | typical 20 s |
| Oil | typical 30 s |
| Air | typical 85 s |

Ordering code

1. 2. 3. 4. 5. 6. 7. 8. 9.
 - - - - - - - - -

| | |
|--------------------------------------|--|
| 1. Type | TC296 |
| 2. Variation | 00 Standard
Ex Ex certified acc. to ATEX Ex-i GD |
| 3. Double-thermocouple | 2J type J (Fe-CuNi)
operating temperature -100..+600 °C
cable color black(+), white(-)
2K type K (NiCr-Ni)
operating temperature -100..+900 °C
cable color green(+), white(-)
2N type N (NiCrSi-NiSi)
operating temperature -100..+1000 °C
cable color pink(+), white(-) |
| 4. Protection tube diameter | 9/6 9mm to 6mm reduced |
| 5. Neck pipe length | 50 50 mm
140 140 mm
XX custom neck pipe |
| 6. Installation length NL | 100 100 mm
160 160 mm
250 250 mm
400 400 mm
600 600 mm
XX custom length |
| 7. Process connection | G 1/2 B |
| 8. Terminal head | BSZ with snap-lid (Aluminum) |
| 9. Max. operating temperature | see Thermocouple |

(Custom variation on request)

Safety RTD Sensor TR296



Connection diagram

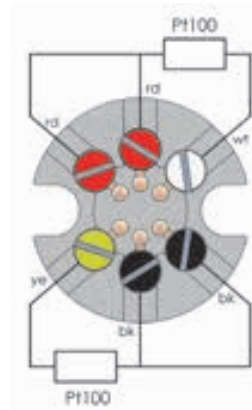

Characteristics

- Fast response sensor for measurement in exhaust gas and air
- Certified as Sensor for Safety Temperature Limiters STL50 for gaseous media acc. to SIL 2 (DIN EN 61508) and DIN EN 14597 (substitute DIN 3440)
- Ex certified to ATEX Ex-i GD for gases and dust
- Sensor with 2 x Pt100 class A, 3-wire
- Max. operating temperature -100..+600 °C
- Process pressure 40 bar
- Protection tube D = 9/6mm, stainless steel 1.4571
- Process connection G 1/2 B
- Terminal head BSZ (Aluminum) IP65 with snap-lid

Temperature equalization

The 63.2 % step-response time of temperature variation at the probe tip will be:

| | |
|---------------|---------------|
| Medium | T63.2% |
| Water | typical 20 s |
| Oil | typical 30 s |
| Air | typical 85 s |

Dimensions

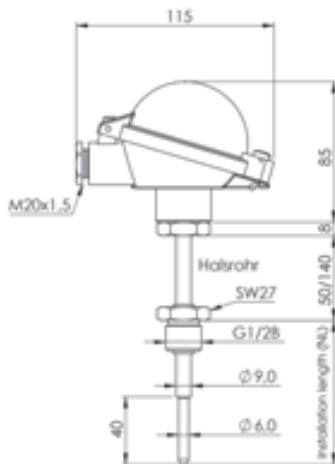

Ordering code

1. 2. 3. 4. 5. 6. 7. 8. 9.
 - - - - - - - - -

| | |
|--------------------------------------|--|
| 1. Type | TR296 |
| 2. Variation | 00 standard
Ex Ex certified acc. to ATEX Ex-i GD |
| 3. Measuring elements | 2 2 elements Pt100 class A, 3-wire |
| 4. Protection tube diameter | 9/6 9mm to 6mm reduced |
| 5. Neck pipe length | 50 50 mm
140 140 mm
XX custom neck pipe |
| 6. Installation length NL | 100 100 mm
160 160 mm
250 250 mm
400 400 mm
600 600 mm
XX custom length |
| 7. Process connection | G 1/2 B |
| 8. Terminal head | BSZ with snap-lid (Aluminum) |
| 9. Max. operating temperature | 600°C |

(Custom variation on request)

Ambient Temperature Sensor 7134 / 7135



Characteristics 7134

- RTD Pt100
- Operating temperature -50 °C..+90 °C
- Measuring element inside- or outside
- Plastic case Polycarbonate, white
- Protection class IP65
- Screw terminals

Characteristics 7135

- RTD Pt100
- Operating temperature -40 °C..+120 °C
- Measuring element outside
- Aluminum case RAL7001, Lid with Silicon sealing
- Protection class IP65
- Screw terminals

Dimensions

7134-x-x-x

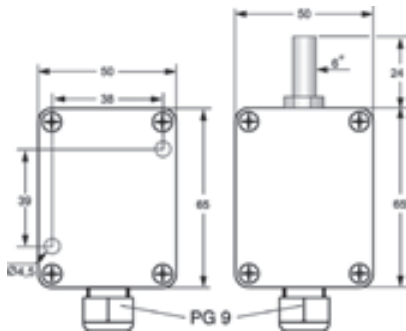

7135-x-x-x

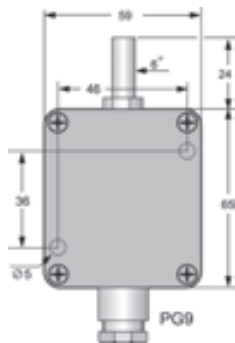

Ordering code

1. 2. 3. 4.
□ - □ - □ - □

| | |
|------------------------------|--------------------|
| 1. Type | |
| 7134 | case Polycarbonate |
| 7135 | case Aluminum |
| 2. Number of elements | |
| 1 | |
| 3. Measuring element | |
| 0 | inside |
| 1 | outside |
| 4. Accuracy | |
| A | class A |
| B | class B |

(other versions on request)

Stock

7134-1-0-B
7134-1-0-A
7134-1-1-B
7134-1-1-A

Temperature Probe (Surface-Mounted Type) GTMU-OMU



- Optimal adaptability due to 4 different design types
- Ready for assembly

Characteristics

The GTMU-OMU is a temperature probe with integrated transmitter. There are 4 basic design types and 3 sensor types. This ensures optimal adaptability to different conditions like higher temperatures, outdoor usage or wall mounting.

The measurement is done by means of a resistive temperature sensor (Pt100 / Pt1000, 2-, 3- or 4- wire) or thermocouple (NiCr-Ni).

The transmitter is completely customized according to customer requirements.

Technical data

Sensor element : Pt100 (2-, 3- or 4- wire)
Pt1000 (2-, 3- or 4- wire)
NiCr-Ni

Standard measuring ranges

Pt100 / Pt1000 : 0..100 °C, 0..200 °C, -50..+50 °C,
-50..+150 °C

NiCr-Ni : 0..100 °C, -50..+150 °C, -200..+300 °C,
0..600 °C, 0..1150 °C
other measuring ranges upon request

Max. possible measuring range

Pt100 / Pt1000 : -200..+800 °C

NiCr-Ni : -40..+1150 °C

Accuracy

Pt100 / Pt1000 : DIN class B

NiCr-Ni : class 1

Working temperature : 0..70 °C (housing and elbow-type plug)

Housing material : ABS

Probe material : stainless steel

Sensor installation : sensors are isolated

Mounting : with fastening holes for wall mounting

Electrical connection : elbow-type plug (EN 175301-803/A)

Protection class : IP65

| | A1 | A2 | A3 | A4 |
|--------------------------------------|-------------|-------------|------------|-------------|
| Process connection (standard) | G ½ | | — | — |
| Fitting length (standard) | EL = 100 mm | EL = 100 mm | EL = 50 mm | EL = 100 mm |
| Neck tube length (standard) | — | HL = 50 mm | — | — |
| Diameter (standard) | D = 6 mm | D = 6 mm | D = 3 mm | D = 6 mm |

Design types

| | |
|-----------|---|
| A1 | with process connection G ½ for screw-in |
| A2 | for higher temperatures, process connection G ½ in distance to housing, HL = length of neck tube |
| A3 | indoor / outdoor probe for wall mounting
<i>(potting of electronics necessary for outdoor application)</i> |
| A4 | duct probe with centrally mounted sensor tube pointing downwards |

Dimensions

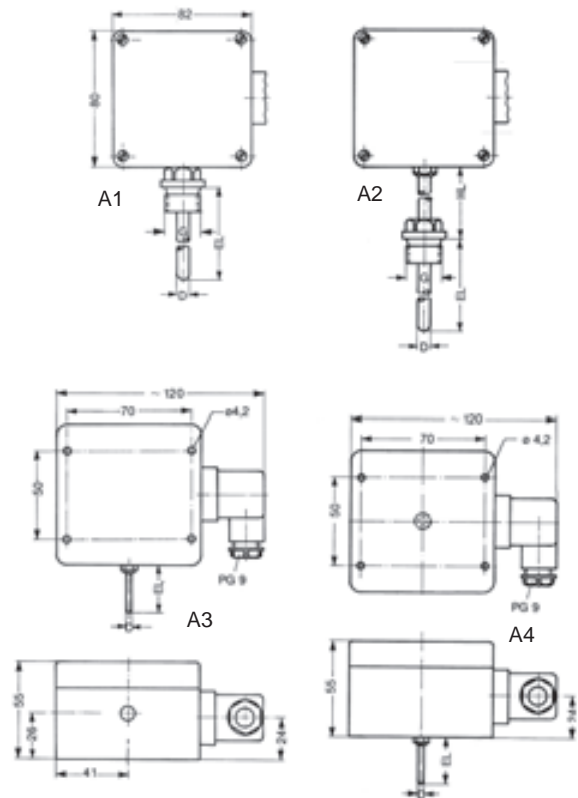

continued on next page

Ordering code

GTMU-OMU - 1. - 2. - 3. - 4. - 5. - 6. - 7.

| | | |
|--|---|------------------------|
| 1. Design type | | |
| A1 | as per description | |
| A2 | as per description | |
| A3 | as per description | |
| A4 | as per description | |
| 2. Sensor element | | |
| P | resistance thermometer Pt100 | |
| T | resistance thermometer Pt1000 | |
| K | thermocouple NiCr-Ni | |
| 3. Measuring range (MB) | | |
| MB1 | 0..100 °C | P / T / K |
| MB2 | -50..+150 °C | P / T / K |
| MB3 | 0..200 °C | only P / T |
| MB4 | -50..+50 °C | only P / T |
| MB5 | -200..+300 °C | only K |
| MB6 | 0..600 °C | only K |
| MB7 | 0..1150 °C | only K |
| MBx | desired measuring range (e.g. -50..+400 °C)
max. possible measuring range:
Pt100: -200..+800 °C / NiCr-Ni: -200..+1150 °C | |
| 4. Fitting length EL | | |
| 050 | 50 mm (standard A3) | |
| 100 | 100 mm (standard A1, A2, A3) | |
| xxx | any EL in mm (e.g.: 200 = 200 mm) | |
| 5. Probe diameter D | | |
| 3 | Ø 3 mm (standard A3) | |
| 4 | Ø 4 mm | |
| 5 | Ø 5 mm | |
| 6 | Ø 6 mm (standard A1, A2, A4) | |
| 8 | Ø 8 mm | |
| 6. Process connection G (only at design type A1 and A2) | | |
| G1 | G ½, V4A (Standard) | |
| G2 | G ¼, V4A | |
| G3 | G ¾, V4A | |
| G5 | G ⅝, V4A | |
| M5 | M5, V4A | only D = 3 mm possible |
| M6 | M6, V4A | only D = 3 mm possible |
| M8 | M8, V4A | max D = 5 mm possible |
| M0 | M10, V4A | max D = 6 mm possible |
| M2 | M12, V4A | |
| 7. Length of neck tube HL (only at design type A2) | | |
| 050 | 50 mm (standard) | |
| xxx | any HL in mm (e.g.: 100 = 100 mm) | |

Temperature Logger
EASYLog 40K
EASYLog 40KH
EASYLog 40KH-300
EASYLog 40KH-600
EASYLog 40KH-GOF



EASYLog 40KH ...

EASYLog 40K

- High battery capacity for long recording duration
- Data memory for 48,000 values
- Long-term monitoring of temperature

Characteristics

The loggers EASYLog 40K and -40KH are designed for long-term monitoring of temperatures, especially in production and server rooms as well as cold storage houses.

EASYLog 40K and -40KH can be used for long-term recording of temperature. Up to 48,000 measured values can be stored.

The combination of low power consumption and high battery capacity ensure long recording duration. The loggers are equipped with a display showing the measured temperature and the operating state of the logger at any time. The industrial housing is splash-water-proof (IP65)

Design types

| | |
|-------------|--|
| ..40K | Sensor tube made of plastic, Ø 7.5 mm, 30 mm long, attached on device |
| ..40KH | Sensor tube made of stainless steel, Ø 5 mm, 50 mm long, 1 m silicone cable, cable attached on housing with kink protection |
| ..40KH-E300 | Sensor tube made of stainless steel, Ø 3 mm, 100 mm long, sleeve Ø 5 x 50 mm, 1 m glass silk cable, cable to housing with kink protection |
| ..40KH-E600 | Sensor tube made of stainless steel, Ø 3 mm, 100 mm long, flexible coating element, sleeve Ø 5 x 50 mm, 1 m silicone cable, cable attached on housing with kink protection |
| ..40KH-GOF | Self-adhesive surface temperature probe with silicone coating for pipe mounting, 2m PFA insulated cable, cable attached on housing with kink protection |

Technical data

| | |
|-------------------------|--|
| Sensor element | : Pt1000 (2-wire) |
| Measuring ranges | |
| EASYLog 40K | : -25.0..+60.0 °C |
| EASYLog 40KH | : -50.0..+150.0 °C |
| EASYLog 40KH-E300 | : -50.0..+300.0 °C |
| EASYLog 40KH-E600 | : -50.0..+600.0 °C |
| EASYLog 40KH-GOF | : -50.0..+150.0 °C |
| Accuracy | |
| Sensor | : DIN class B |
| Electronics | : 40K: ±0.5 °C
40KH: ± 0.5 °C
40KH-E300: ±0.5 °C ±0.2 % of m.v.
40KH-E600: ±1 °C ±0.2 % of m.v.
40KH-GOF: ±0.5 °C ±0.2 % of m.v. |
| Working temperature | : -25..+60 °C (electronics) |
| Storage capacity | : 48.000 measured values |
| Recording | : interval 2 s to 5 h / duration 500 days (at 15 min recording interval) |
| Power supply | : battery operation, service life approx. 6 years (at 15 min recording interval) |
| Interface | : EASYBus interface, 3-pin mini built-in plug |
| Housing | : ABS |
| Protection class | : IP65 |

Dimensions

| | |
|---------|--|
| Housing | : 48.5 x 48.5 x 35.5 mm
plug and cable not included |
|---------|--|

continued on next page

Ordering code

EASYLog - 1. - 2.

| 1. Design type | |
|---|---|
| 40K | as per description |
| 40KH | as per description |
| 40KH-E300 | as per description |
| 40KH-E600 | as per description |
| 40KH-GOF | as per description |
| 2. Options (combination of multiple options upon request) | |
| 000 | without option |
| DBK | double battery capacity
(recommended for fast measuring rates) |
| ALARM | additional alarm output
open-collector-output, 4-pin mini built-in plug
(IP65) incl. 1 m connection cable,
max. switching power: 28 V, 50 mA |
| AFK | plug-able probe-cable
4-pin mini build-in plug (IP65) incl. assembling of
the temperature probe to the corresponding con-
nection socket |
| SMB | special measuring range
freely selectable between -200..+600 °C
(state special measuring range separately) |

Necessary accessories

The EASYLog 40K... is programmed, started and read via its EASYBus interface. Following accessories are required:

- interface converter
RS232 – EASYBus: EBW 1, EBW 64, EBW 240
or USB – EASYBus: EBW 3
- GSOFT 40K (as of Version 5.0) to start logger and read
logger data incl. 1x EBSK 01 connection cable
- EBSK 01 / EBSK 03 (1m or 3m): connection cable from in-
terface converter to EASYLog

Note: 1x EBSK 01 (1m) is in scope of delivery of software
software GSOFT 40K.

Temperature Probe with Transmitter GTMU

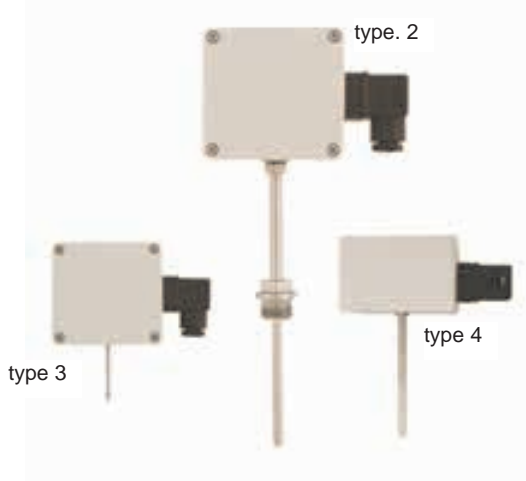

- Optimal adaptability due to 4 different design types
- PT100 or NiCr-Ni probe incl. transmitter
- Ready for assembly

Characteristics

The GTMU is a temperature probe with integrated transmitter. There are 4 basic design types and 2 sensor types. This ensures optimal adaptability to different conditions like higher temperatures, outdoor usage or wall mounting.

The measurement is done by means of a resistive temperature sensor (Pt100, 2- or 3- wire) or thermocouple (NiCr-Ni). The transmitter outputs linear current or voltage signals.

The transmitter is completely customized according to customer requirements.

Technical data

| | |
|--------------------------------------|--|
| Sensor element | : Pt100
NiCr-Ni |
| Standard measuring range | |
| Pt100 | : 0..100 °C, 0..200 °C, -50..+50 °C,
-50..+150 °C |
| NiCr-Ni | : 0..100 °C, -50..+150 °C,
-200..+300 °C, 0..600 °C,
0..1150 °C
other measuring ranges upon request |
| Max. possible measuring range | |
| Pt100 | : -200..+800 °C |
| NiCr-Ni | : -200..1150 °C |
| Accuracy | |
| Pt100 | : DIN class B |
| NiCr-Ni | : class 1 |
| Output signal | : standard 4..20 mA (2-wire)
optional 0..1 V, 0..2 V, 0..5 V,
0..10V (3- or 4-wire) |
| Power supply U_v | : 12..30 V DC (at 0..10 V: 18..30 V DC) |
| Permissible burden R_A | : (at 4..20 mA) $R_A = (U_v - 12 V) / 0,02 A$ |
| Permissible load R_L | : (at ... V) $R_L > 3000 \Omega$ |
| Working temperature | : 0..70 °C
(-40..+85 °C at option RT420 / GITT) |
| Housing material | : ABS |
| Probe material | : stainless steel |

| | |
|-----------------------|--|
| Protection class | : IP65 |
| Sensor installation | : sensors are isolated |
| Mounting | : with fastening holes for wall mounting |
| Electrical connection | : elbow-type plug (EN 175301-803/A) |

| | type 1 | type 2 | type 3 | type 4 |
|--------------------------------------|-------------|-------------|------------|-------------|
| Process connection (standard) | G ½ | | — | — |
| Fitting length (standard) | EL = 100 mm | EL = 100 mm | EL = 50 mm | EL = 100 mm |
| Neck tube length (standard) | — | HL = 50 mm | — | — |
| Diameter (standard) | D = 6 mm | D = 6 mm | D = 3 mm | D = 6 mm |

Design types

| | |
|---------------|---|
| Type 1 | with process connection G ½ for screw-in |
| Type 2 | for higher temperatures, process connection G ½ in distance to housing, HL = length of neck tube |
| Type 3 | indoor / outdoor probe for wall mounting
<i>(potting of electronics necessary for outdoor application)</i> |
| Type 4 | duct probe with centrally mounted sensor tube pointing downwards |

Dimensions

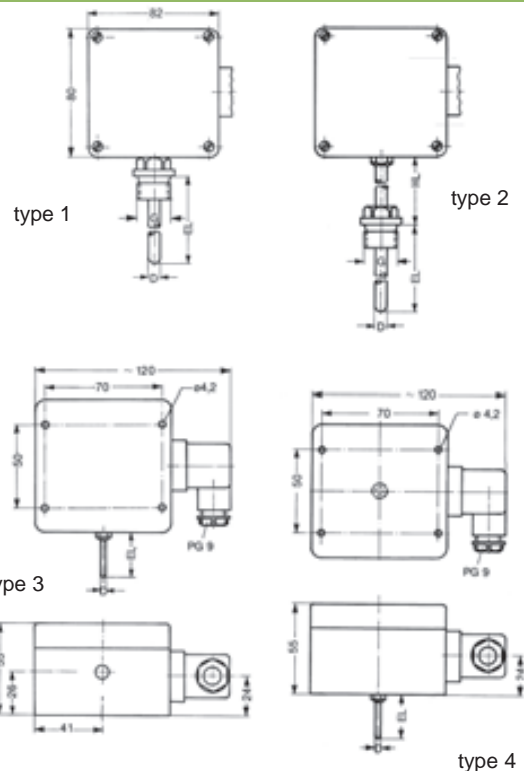

continued on next page

Connection diagram

2-wire connection (4..20 mA)

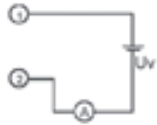

1 = supply voltage +Uv
2 = GND / signal

3-wire connection (.. V DC)

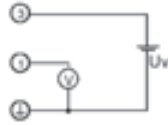

1 = signal +
3 = supply voltage +Uv
↓ = supply voltage -Uv
signal -

4-wire connection (.. V DC)

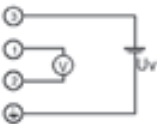

1 = signal +
2 = signal -
3 = supply voltage +Uv
↓ = supply voltage -Uv

Ordering code

1. 2. 3. 4. 5. 6. 7. 8. 9.
GTMU - - - - - - - - -

| | |
|--------------------------------|---|
| 1. Design type | |
| A1 | duct / wall design with thread |
| A2 | duct design for higher temperatures |
| A3 | indoor / outdoor probe |
| A4 | duct design without thread |
| 2. Sensor element | |
| P | resistance thermometer Pt100 |
| K | thermocouple NiCr-Ni |
| 3. Measuring range (MB) | |
| MB1 | 0..100 °C <i>Pt100 / NiCr-Ni</i> |
| MB2 | -50..+150 °C <i>Pt100 / NiCr-Ni</i> |
| MB3 | 0..200 °C <i>only Pt100</i> |
| MB4 | -50..+50 °C <i>only Pt100</i> |
| MB5 | -200..+300 °C <i>only NiCr-Ni</i> |
| MB6 | 0..600 °C <i>only NiCr-Ni</i> |
| MB7 | 0..1150 °C <i>only NiCr-Ni</i> |
| MBx | desired measuring range (e.g. -50..+400 °C)
max. possible measuring range:
Pt100: -200..+800 °C / NiCr-Ni: -200..+1150 °C |
| 4. Output signal | |
| A1 | 4..20 mA (2-wire) (standard) |
| V1 | 0..1 V (3-/ 4-wire) |
| V3 | 0..2 V (3-/ 4-wire) |
| V4 | 0..5 V (3-/ 4-wire) |
| V2 | 0..10 V (3-/ 4-wire) |
| 5. Fitting length EL | |
| 050 | 50 mm (standard A3) |
| 100 | 100 mm (standard A1, A2, A3) |
| xxx | any EL in mm (e.g.: 200 = 200 mm) |

| | |
|--|--|
| 6. Probe diameter D | |
| 3 | Ø 3 mm (standard A3) |
| 4 | Ø 4 mm |
| 5 | Ø 5 mm |
| 6 | Ø 6 mm (standard A1, A2, A4) |
| 8 | Ø 8 mm |
| 7. Process connection G (only at design type A1 and A2) | |
| G1 | G ½ (V4A) (standard) |
| G2 | G ¼ (V4A) |
| G3 | G ⅜ (V4A) |
| M5 | M5 (V4A) |
| M6 | M6 (V4A) |
| M8 | M8 (V4A) |
| M0 | M10 (V4A) |
| M2 | M12 (V4A) |
| 8. Length of neck tube HL (only at design type A2) | |
| 050 | 50 mm (standard) |
| xxx | any HL in mm (e.g.: 200 = 200 mm) |
| 9. Options (combination of multiple options upon request) | |
| 00 | without Option |
| VO | on-site display (display and control panel) |
| LACK | board varnished on both sides (for outdoor usage) |
| GITT | transmitter with electrical isolation (only output 4..20 mA possible) |
| RT420 | transmitter particular for outdoor usage (only with sensor element Pt100 and output 4..20 mA possible) |

Temperature Probe with Transmitter GTMU-MP

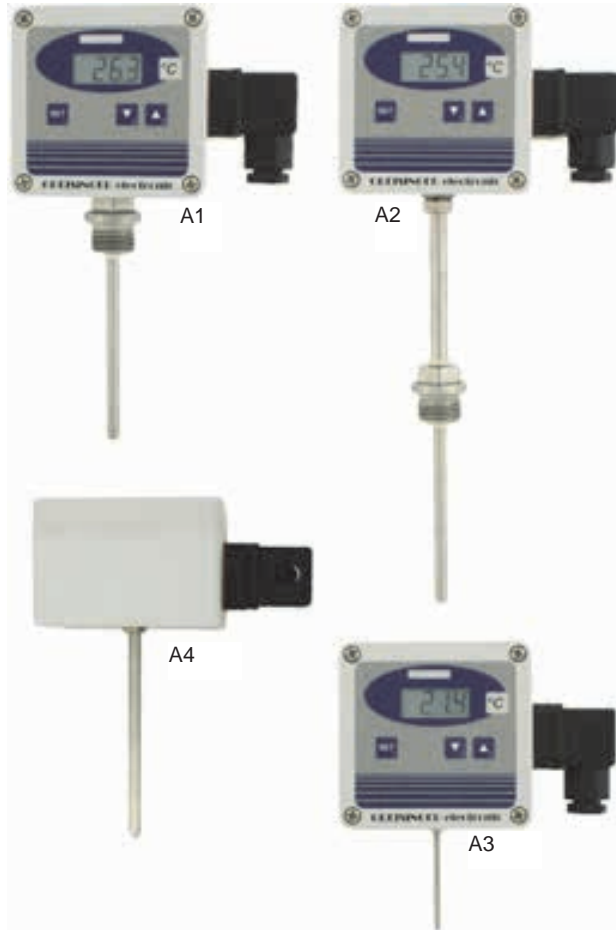

- Optimal adaptability due to 4 different design types
- Freely scalable measuring range
- With display by default

Characteristics

The GTMU-MP is a temperature probe with integrated transmitter. There are 4 basic design types. This ensures optimal adaptability to different conditions like higher temperatures, outdoor usage or wall mounting.

The measurement is done by means of a resistive temperature sensor (Pt1000, 2-wire). The measuring range is freely scalable via buttons. The transmitter outputs linearized current or voltage signals.

The GMTU-MP has a display by default and is completely customized according to customer requirements.

Technical data

Sensor element : Pt1000 (2-wire)
 Measuring range : -50.0..+400.0 °C, freely scalable
 Accuracy :
 Temperature display : ±0.4 % of m.v. ±0.2 °C
 Output signal : ±0.2 % FS
 Output signal : standard 4..20 mA (2-wire)

Power supply U_v : optional 0..1 V, 0..10V (3- / 4- wire)
 : 12..30 V DC (standard),
 : 18..30 V DC at output signal .. V
 Permissible burden R_A : (at 4..20 mA) $R_A = (U_v - 12 V) / 0.02 A$
 Permissible load R_L : (at ... V) $R_L > 3000 \Omega$
 Working temperature : -25..+70 °C (electronics)
 Housing material : ABS
 Probe material : stainless steel
 Protection class : IP65
 Mounting : with fastening holes for wall mounting or
 : with tube support made of plastic for
 : duct mounting
 Electrical connection : elbow-type plug (EN 175301-803/A)
Display
 Display : LCD-display
 Height : 10 mm
 Display range : 4 digit
Functions : Min-/max- value memory
 : Zero point / slope digitally adjustable
 : output signal freely scalable

| | A1 | A2 | A3 | A4 |
|--------------------------------------|-------------|-------------|------------|-------------|
| Process connection (standard) | G ½ | | — | — |
| Fitting length (standard) | EL = 100 mm | EL = 100 mm | EL = 50 mm | EL = 100 mm |
| Neck tube length (standard) | — | HL = 100 mm | — | — |
| Diameter (standard) | D = 6 mm | D = 6 mm | D = 3 mm | D = 6 mm |

Design types

| | |
|-----------|---|
| A1 | with process connection G ½ for screw-in |
| A2 | for higher temperatures, process connection G ½ in distance to housing, HL = length of neck tube |
| A3 | indoor / outdoor probe for wall mounting
<i>(potting of electronics necessary for outdoor application)</i> |
| A4 | duct probe with centrally mounted sensor tube pointing downwards |

Dimensions

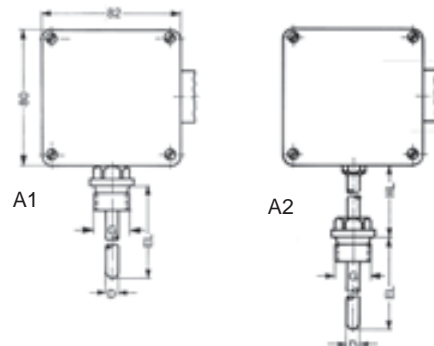

continued on next page

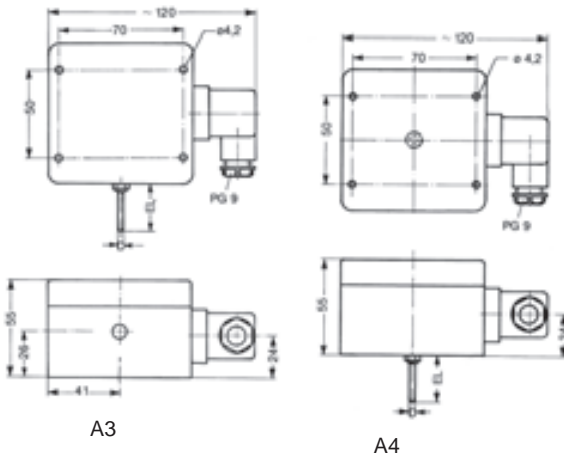

Ordering code

GTMU-MP - 1. - 2. - 3. - 4. - 5. - 6. - 7.

| | | |
|--|---|-------------------------------|
| 1. Design type | | |
| A1 | as per description | |
| A2 | as per description | |
| A3 | as per description | |
| A4 | as per description | |
| 2. Output signal | | |
| A1 | 4..20 mA (2-wire) (standard) | |
| V1 | 0..1 V (3-/ 4-wire) | |
| V2 | 0..10 V (3-/ 4-wire) | |
| 3. Fitting length EL | | |
| 050 | 50 mm (standard A3) | |
| 100 | 100 mm (standard A1, A2, A3) | |
| xxx | any EL in mm (e.g.: 200 = 200 mm) | |
| 4. Probe diameter D | | |
| D03 | Ø 3 mm (standard A3) | |
| D04 | Ø 4 mm | |
| D05 | Ø 5 mm | |
| D06 | Ø 6 mm (standard A1, A2 and A4) | |
| D08 | Ø 8 mm | |
| 5. Thread (only at design type A1 and A2) | | |
| G1 | G ½, V4A (standard) | |
| G2 | G ¼, V4A | |
| G3 | G ¾, V4A | |
| G5 | G ⅝, V4A | |
| M5 | M5, V4A | <i>only D = 3 mm possible</i> |
| M6 | M6, V4A | <i>only D = 3 mm possible</i> |
| M8 | M8, V4A | <i>max. D = 5mm possible</i> |
| M0 | M10, V4A | <i>max. D = 6mm possible</i> |
| M2 | M12, V4A | |
| 6. Length of neck tube HL (only at design type A2) | | |
| 100 | 100 mm (standard) | |
| xxx | any HL in mm (e.g.: 500 = 500 mm) | |
| 7. Options (combination of multiple options upon request) | | |
| 000 | without Option | |
| LACK | board varnished on both sides (for outdoor usage) | |
| DSG | Double sensor accuracy | |

Temperature Transmitter GTMU - IF

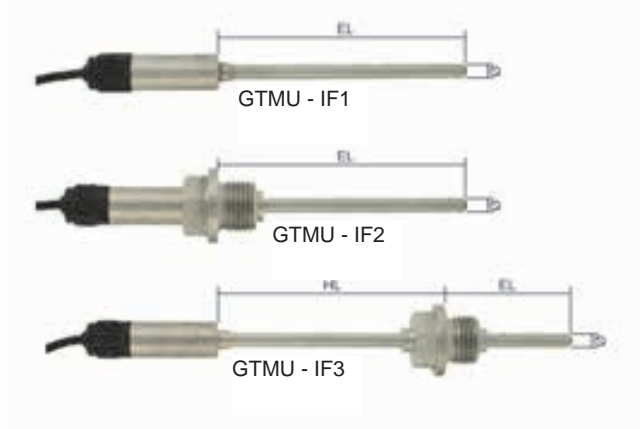

- Internal Pt1000
- Housing made of stainless steel
- Long-term temperature monitoring

Characteristics

The GTMU-IF is designed for long-term monitoring of temperatures. It is particularly suitable for narrow and difficult to access measuring points due to its compact design.

The temperature transmitter GTMU-IF has an internal Pt1000 sensor that measures the temperature. The measured values are output via linearized 4..20 mA signal.

The housing of the sensor module is made of stainless steel and is therefore optimally protected against corrosion. The modules can be modified according to customer requirements.

Technical data

| | GTMU - IF1 | GTMU - IF2 | GTMU - IF3 |
|-------------------------------|--|------------------|------------------|
| Measuring range | -30.0..+100.0 °C | -30.0..+100.0 °C | -70.0..+400.0 °C |
| Sensor element | Pt1000 sensor | | |
| Accuracy | electronics: ±0.2 % of m.v. ±0.2 °C
sensor element: DIN class B | | |
| Working temperature | -25..+70 °C (electronics in cable sleeve) | | |
| Process connection (standard) | — | thread G ½ | thread G ½ |
| Fitting length (standard) | EL = 100 mm | EL = 100 mm | EL = 50 mm |
| Neck tube length (standard) | — | — | HL = 100 mm |
| Probe diameter (standard) | Ø 6 mm | Ø 6 mm | Ø 6 mm |
| Housing | stainless steel V4A (potted) | | |

Dimensions

Cable sleeve : Ø 15 x 35 mm (without threaded connection)

Ordering code

GTMU - 1. - 2. - 3. - 4. - 5. - 6.

| | |
|---|---|
| 1. Design type | |
| IF1 | without thread |
| IF2 | with tread G ½ |
| IF3 | with tread G ½ and neck tube |
| 2. Measuring range | |
| MB1 | -30.0..+100.0 °C (standard IF1 and IF2) |
| MB2 | -70.0..+400.0 °C (standard IF3) |
| MBx | other ranges upon request, indicate measuring range separately (max. possible meas. range: -200..+500 °C) |
| 3. Fitting length EL | |
| 0050 | 50 mm (standard IF3) |
| 0100 | 100 mm (standard IF1 and IF2) |
| xxxx | any EL in mm (e.g.: 0700 = 700 mm) |
| 4. Probe diameter D | |
| D4 | Ø 4 mm |
| D5 | Ø 5 mm |
| D6 | Ø 6 mm (Standard) |
| D8 | Ø 8 mm |
| 5. Process connection (only at design IF2 and IF3) | |
| G1 | G ½ (standard) |
| G2 | G ¼ |
| G3 | G ¾ |
| G4 | G ⅙ |
| G5 | G ⅜ |
| M8 | M8x1 |
| M0 | M10x1 |
| M4 | M14x1,5 |
| 6. Length of neck tube HL (only at design IF3) | |
| 100 | 100 mm (standard) |
| xxx | any HL in mm (e.g.: 200 = 200 mm) |

Accessories

Programming tool for GTMU-IF

- The programming tool contains
- a multilingual configuration software
 - USB interface adapter for GTMU-IF

Option

Sensor element 1/3 DIN class B or class A on requirement.

Temperature Transmitter ETS



- 4..20 mA two-wire temperature transmitter
- Lance-shaped with small bulk
- Compact construction available
- Short response time
- Infinitely adjustably rotatable cable outlet for clean alignment

Characteristics

The temperature sensor consists of a PT1000 resistance sensor, which has very good dynamic behaviour. The temperature-dependent change in resistance is linearised by the downstream electronics, and converted into a temperature-proportional 4..20 mA signal. The sensor is supplied with < 4 mA, so it was possible to implement a two-wire connection. At the same time, this process connection allows monitoring for wire breaks. Because the complete upper part of the housing can be turned, it is possible to simply and infinitely adjust the cable outlet.

Technical data

| | | |
|-----------------------------|--|---|
| Sensor | platinum resistance sensor | |
| Process connection | male thread G 1/4 A.. G 1/2 A, union nut G 3/4 or Tri-clamp connection | |
| Metering range | 0..100 °C | standard range |
| | 0..200 °C | extended range for lance shape with gooseneck |
| | range -20..+200 °C or partial ranges available on request | |
| Measurement accuracy | ±1 K | |
| Repeatability | ±0.1 K | |
| Dynamic (t) | 3 s | |
| | | |
| Pressure | Lance shape | PN 25 |
| | Compact construction | PN 100 |
| Medium | as metering range | |

| | |
|--------------------------------------|---|
| temperature | |
| Ambient temperature | -20..+70 °C |
| Storage temperature | -20..+80 °C |
| Media | water, viscous media, gases |
| Materials medium-contact | 1.4571 |
| Materials, non-medium-contact | FKM, CW614N nickelled, PP |
| Supply voltage | 10..30 V DC |
| Analog output | 4..20 mA two-wire |
| Load | 800 Ω at 24 V
(100 Ω at 10 V – 1.1 k Ω at 30 V, linear at operating voltage) |
| Electrical connection | for round plug connector M12x1, 4-pole or plug DIN 43650-A |
| Ingress protection | IP 67 (round plug connector)
IP 65 (plug DIN 43650-A) |
| Weight | approx. 0.2 kg |
| Conformity | CE |

Wiring

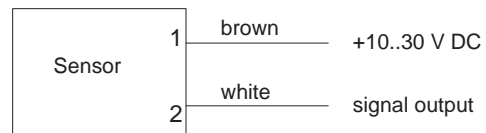

Before the electrical installation, it must be ensured that the supply voltage corresponds with the data sheet.

Dimensions

Lance shape

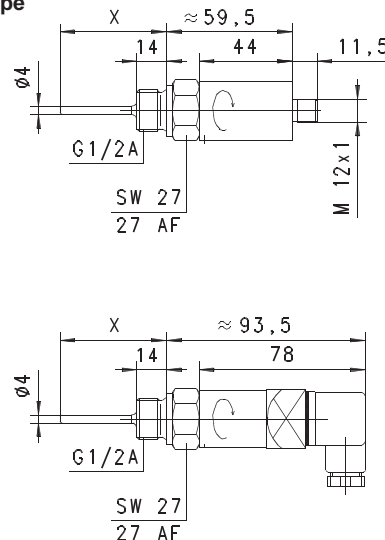

| Lance type | Length X | Screw-in thread |
|------------|----------|-----------------|
| ..050.. | 50 | G 1/2 A |
| ..100.. | 100 | G 1/2 A |
| ..150.. | 150 | G 1/2 A |
| ..200.. | 200 | G 1/2 A |

Compact sensor

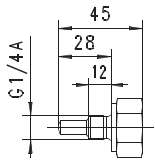

Screw-in sensor G 1/4 A
Type ..028..

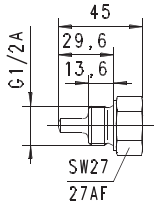

Screw-in sensor G 1/2 A
Type ..029..

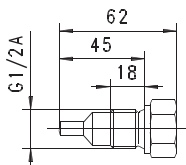

Screw-in sensor G 1/2 A
Type ..045..

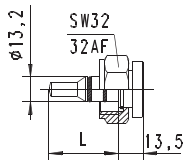

Sensor with union nut for
T-piece G 3/8..G 1/2
Type ..031.. (L = 31 mm)
or
T-piece G 3/4..G 2
Type ..037.. (L = 37 mm)

"Gooseneck" option for higher temperatures

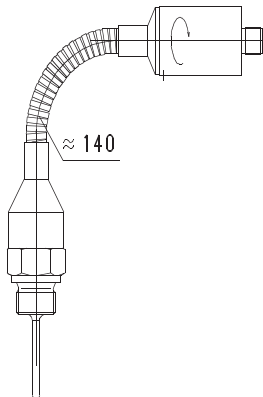

Handling and operation

Installation

Sensors with screw-in threads are screwed into a T-piece or a nozzle in the pipework, using a suitable flat seal (e.g. Klingerit). Sensors with a union nut are mounted in a T-piece (see separate product information). Use only a hexagonal spanner to tighten! It should be ensured that the sensor tip is located fully in the medium, and does not push against the wall of the pipe. The upper part of the sensor with the connector output can be turned steplessly in order to align the cable outlet.

Ordering code

ETS

ETS - 1. 2. 3. 4. 5. 6.
ETS - **K**

Option =

| | | | |
|---------------------------------|--|----------------------|----------------------------|
| 1. Metering range | | | |
| 100 | range 0..100 °C | | |
| 200 | <input type="checkbox"/> range 0..200 °C | | |
| 2. Connection material | | | |
| K | stainless steel 1.4571 | | |
| 3. Connection size | | | |
| 008 | connection G 1/4 A | | |
| 013 | connection for T-piece | | |
| 015 | connection for G 1/2 A | | |
| 4. Electrical connection | | | |
| S | for round plug connector M12x1 | | |
| B | DIN 43650-A plug | | |
| 5. Process connection | | | |
| 050 | lance length | 50 mm Ø 4 mm | ● ● |
| 100 | | 100 mm Ø 4 mm | ● ● |
| 150 | | 150 mm Ø 4 mm | ● ● |
| 200 | | 200 mm Ø 4 mm | ● ● |
| 028 | sensor length | 28 mm (G 1/4 A) | ● |
| 029 | | 29.6 mm (G 1/2 A) | ● |
| 045 | | 45 mm (G 1/2 A) | ● |
| 031 | sensor for | T-piece G 3/8..G 1/2 | ● |
| 037 | | T-piece G 3/4..G 2 | ● |
| 6. Option | | | |
| H | <input type="checkbox"/> model with gooseneck for metering range 0..200 °C | | <input type="checkbox"/> ● |

Options

- Range -20..+200 °C

Accessories

- T-piece type TS-2... Thread G 3/8..G 2
- Cable/round plug connector (KB...) see additional information "Accessories"
- Evaluation electronics OMNI-TA

Temperaturtransmitter ETK12-I / U / F

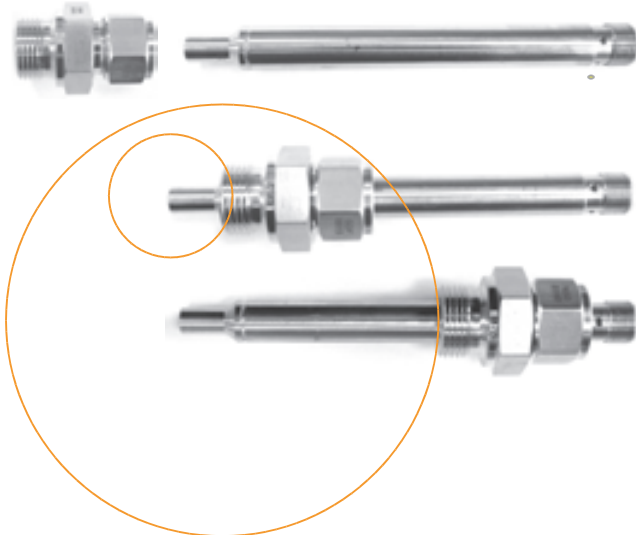

- Kompletter Transmitter im 12 mm-Gehäuse!
- Analogausgang 4..20 mA (ETK12-I)
- Analogausgang 0..10 V (ETK12-U)
- Frequenzausgang (ETK12-F)
- Für unterschiedliche Rohrnenweiten der gleiche Transmitter
- Benutzer konfigurierbar über Steckerpin (Teach-In)
- Gleiche mechanische Ausführung als Temperaturschalter, Durchflusstransmitter / -schalter oder als Füllstandschalter erhältlich!

Merkmale

Die Sensoren der ETK12-Familie sind zur Messung und Überwachung von Temperaturen in strömenden Medien einsetzbar. Sie bieten bei geringem Platzbedarf eine variable Fühlerlänge sowie unterschiedliche Befestigungsmöglichkeiten. Der 16-bit-Prozessor sorgt für eine Linearisierung der PT2000-Kennlinie und gibt das normierte Ausgangssignal aus.

Die ETK12-Elektronik gibt das Ergebnis aus als

- Analoges 0/4..20 mA-Signal (ETK12-I)
- Analoges 0/2..10 V-Signal (ETK12-U)
- Frequenzsignal (ETK12-F)

Der Bereichsendwert kann auf Wunsch über Teach-In bei jeweils anstehender Temperatur eingestellt werden (siehe Handhabung und Betrieb).

Technische Daten

| | | |
|---------------------------|---|-----------------|
| Sensor | Platin-Widerstandsfühler | |
| Anschlussart | Edelstahlverschraubung G 1/2 A oder Kunststoffverschraubung M12x1,5 | |
| Nennweite | für DN 15..300, andere auf Anfrage | |
| Messbereich | 0..100 °C | Standardbereich |
| | -20..+100 °C
(oder Teile davon) | auf Anfrage |
| Messunsicherheit | ±1 °C | |
| Reproduzierbarkeit | ±0,5 °C | |

| | | |
|---------------------------------------|--|--|
| Dynamik (τ) | 3 s | |
| | | |
| Druck | PN 63 (mit Edelstahlverschraubung)
PN 4 (mit Kunststoffverschraubung) | |
| Medientemperatur | -20..+100 °C | |
| Umgebungstemperatur | 0..60 °C | |
| Lagertemperatur | -20..+70 °C | |
| Medien | Flüssigkeiten und Gase | |
| Werkstoffe medienberührt | Gehäuse 1.4571 | |
| Werkstoffe nicht medienberührt | Stecker | PA |
| | Kontakte | vergoldet |
| Versorgungsspannung | 18..30 V DC (geregelt) | |
| Ruhestromaufnahme | < 60 mA | |
| Ausgang | ETK12-I | 4..20 mA
Last max. 500 Ohm |
| | ETK12-U | 0..10 V
Last min. 1 kOhm |
| | ETK12-F | Frequenzausgang
"Push-Pull" (kurzschluss- und verpolungsfest)
I _{out} = 100 mA max.
Ausgangsfrequenz wählbar, max. 2 kHz |
| Elektrischer Anschluss | für Rundsteckverbinder M12x1, 4-polig | |
| Schutzart | IP 67 | |
| Gewicht | ca. 0,05 kg ohne Verschraubung | |
| Konformität | CE | |

Anschlussbild

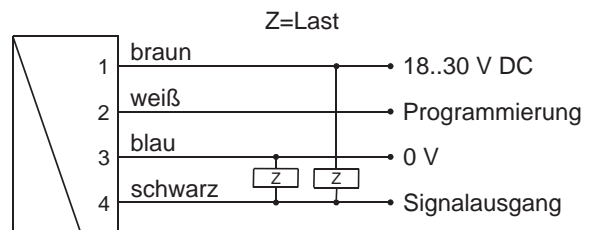

Anschlussbeispiel: PNP NPN

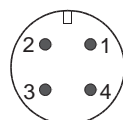

Die Verwendung abgeschirmter Leitungen wird empfohlen!

Abmessungen

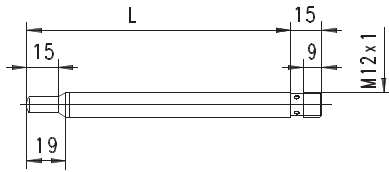

Optionales Zubehör

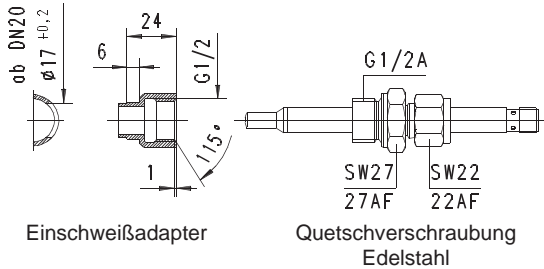

Einschweißadapter

Quetschverschraubung
Edelstahl

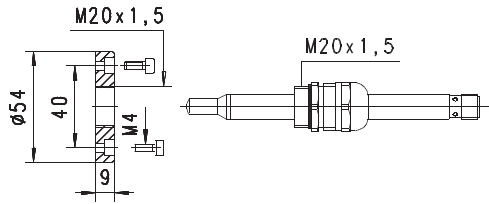

Flanschbefestigung
Kunststoff

Quetschverschraubung
Kunststoff

Handhabung und Betrieb

Hinweise

Der Messbereichsendwert kann vom Benutzer per Teach-In programmiert werden. Die Programmierbarkeit muss bei der Bestellung angegeben werden, anderenfalls ist das Gerät nicht programmierbar.

Als komfortable Programmiermöglichkeit per PC für alle Parameter und zur Justierung steht das Interface ECI-1 mit zugehöriger Software zur Verfügung.

Montage

Die Fühlerspitze sollte sich möglichst in der Mitte des Rohres befinden. Bei vorhandener Strömung sollte das x angeströmt werden, um eine geringstmögliche Reaktionszeit zu erreichen.



Blasen oder Ablagerungen am Sensor sind zu vermeiden! Die beste Einbaulage ergibt sich daher von der Seite.

Die Edelstahlverschraubung wird zunächst von Hand angezogen und dann mit Hilfe eines Schlüssels 1/4 Umdrehung weiter festgezogen. Der Klemmring der Verschraubung ist anschließend nicht mehr vom Sensor entferbar, die Eintauchtiefe also nicht mehr änderbar!

Bedienung und Programmierung

Das Messbereichsende ist auf Wunsch per Teach-In durch den Anwender einstellbar.

Hierzu ist wie folgt vorzugehen:

- Gerät mit der einzustellenden Temperatur beaufschlagen
- Impuls von mindestens 0,5 s und max. 2 s Dauer an Pin 2 anlegen (z.B. durch Brücke zur Versorgungsspannung oder Puls von SPS), um den gemessenen Wert zu übernehmen.
- Nach erfolgtem Teach-In sollte Pin 2 mit 0 V verbunden werden, um versehentliche Programmierung zu verhindern.

Die Geräte besitzen eine gelbe LED, die während des Programmierpulses blinkt. Im Betrieb dient die LED als Betriebsspannungsanzeige.

Um zu vermeiden, dass für das Teach-In ein unerwünschter Betriebszustand angefahren werden muss, kann das Gerät ab Werk mit einem Teach-Offset versehen werden. Der Teach-Offset-Wert wird vor dem Abspeichern zum aktuellen Messwert addiert.

Beispiel: Das Messbereichsende soll auf 80 °C eingestellt werden. Gefahrlos sind aber nur 60 °C zu erreichen. In diesem Fall würde das Gerät mit einem Teach-Offset von +20 °C bestellt werden. Bei 60 °C im Prozess würde dann beim Teachen ein Wert von 80 °C gespeichert werden.

Bestellschlüssel

ETK12 - 1. 2. K1 4. 5. 6

○ = Option

| | |
|------------------------------|--|
| 1. Analogausgang | |
| I | Stromausgang 4..20 mA |
| U | Spannungsausgang 0..10 V |
| F | Frequenzausgang |
| 2. Fühlerlänge L = | |
| 100 | 123 mm |
| 150 | 173 mm |
| 200 | 223 mm |
| 3. Anschlusswerkstoff | |
| K1 | Edelstahl 1.4571 |
| 4. Programmierung | |
| N | nicht programmierbar (kein Teach-In) |
| P | <input type="checkbox"/> programmierbar (Teach-In möglich) |
| 5. Schaltertyp | |
| L | Minimum-Schalter |
| H | Maximum-Schalter |
| 6. Ausgang | |
| O | Ausgang nicht invertiert |
| I | <input type="checkbox"/> Ausgang invertiert |

Optionen

Für ETK12-I und ETK12-U

Sonderbereich Analogausgang:

Messbereichsanfang (4 mA bzw. 0 V) bei °C
Standard = 0 °C

Messbereichsende (20 mA bzw. 10 V) bei °C
Standard = 100 °C

Teach-Offset (-100..+100 °C) °C
Standard = 0 °C

Für ETK12-F

Endfrequenz (max. 2000 Hz) Hz
Standard = 2000 Hz

Sonderbereich Frequenzausgang:

Messbereichsanfang (0 Hz) bei °C
Standard = 0 °C

Messbereichsende (Endfrequenz) bei °C
Standard = 100 °C

Teach-Offset (-100..+100 °C) °C
Standard = 0 °C

Weitere Optionen auf Anfrage!

Zubehör

- Verschraubungen
- Einschweißadapter
- Rundsteckverbinder
- Gerätekonfigurator ECI-1

Temperature Switch ETK12-S



- Temperature sensor with limit switch in 12 mm housing
- The same transmitter for various piping widths
- User-configurable via plug pin (teaching)
- Same mechanical design available, whether temperature transmitter, flow transmitter / switch or level switch

Characteristics

The sensors of the ETK12 family can be used for measuring and monitoring temperatures in flowing media. They require little space, yet offer a variable sensor length, as well as various fastening options.

The electronics of the ETK12-S are a flexibly configurable limit switch.

The switching value can be set by the user via teaching (see Handling and Operation). All other values have been preset at the factory, but can be modified by the user with the aid of the optionally available ECI-3 device configurator and a PC.

The adjustable parameters are:

- Switching value
- Hysteresis
- Minimum/maximum monitoring
- Switching delay
- Switchback delay
- Power-On delay
- Teach-Offset

Technical data

| | | |
|-------------------------------------|--|-------------|
| Sensor | platinum resistance sensor | |
| Process connection | stainless steel threaded connection G 1/2 A or plastic threaded connection M12x1.5 | |
| Nominal width | for DN 15..300, others available on request | |
| Switching range | -20..+100 °C | |
| Measurement accuracy | ±1 °C | |
| Reproducibility | ±0.5 °C | |
| Dynamic (t) | 3 s | |
| Pressure | PN 63 (with stainless steel threaded connection) PN 4 (with plastic threaded connection) | |
| Medium temperature | -20..+100 °C | |
| Ambient temperature | 0..60 °C | |
| Storage temperature | -20..+70 °C | |
| Media | fluids and gases | |
| Materials medium-contact | Housing | 1.4571 |
| Materials non-medium-contact | Plug | PA |
| | Contacts | gold-plated |
| Supply voltage | 18..30 V DC (regulated) | |
| Current consumption | < 60 mA | |
| Switching output | transistor output "push-pull" (resistant to short circuits and polarity reversal)
$I_{out} = 100 \text{ mA max.}$ | |
| Electrical connection | for round plug connector M12x1, 4-pole | |
| Ingress protection | IP 67 | |
| Weight | approx. 0.05 kg (excluding screwed connection) | |
| Conformity | CE | |

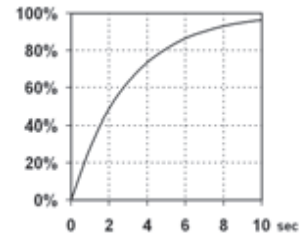

Wiring

The use of shielded cabling is recommended.

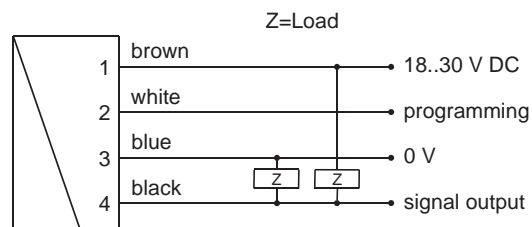

Connection example: PNP NPN

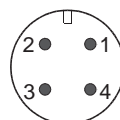

Dimensions

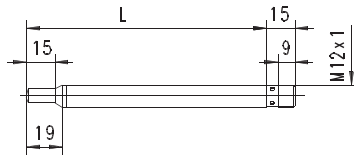

Optional accessories

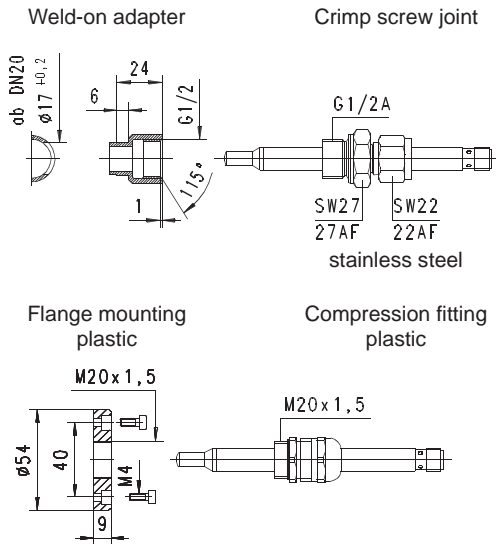

Handling and operation

Installation

Wherever possible, the sensor tip should be positioned in the middle of the pipe. When a flow is present, it should impinge onto the X, in order to achieve the lowest possible response time.

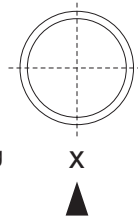

Avoid bubbles or deposits on the sensor. It is therefore best to install at the side. The stainless steel threaded connection is first tightened by hand, and then by 1/4 of a turn, using a spanner. The connection ring of the threaded connection can then no longer be removed from the sensor, and the immersion depth can therefore not be changed further.

Operation and programming

The switching value can be set by the user by means of teaching. For this, proceed as follows:

- The temperature which is to be set is applied to the device.
- Apply a pulse of at least 0.5 seconds and max. 2 seconds duration to pin 2 (e.g. via a bridge to the supply voltage or a pulse from the PLC), in order to accept the measured value.
- When the teaching is complete, pin 2 should be connected to 0 V, so as to prevent unintended programming.

The device has a yellow LED which flashes during the programming pulse. During operation, the LED serves as a status display for the switching output. In order to avoid the need to transit to an undesired operating

status during the teach-in, the device can be provided ex-works with a teach-offset. The teach-offset point is added to the currently measured value before saving.

Example: The switching value is to be set to 80 °C, because at this temperature a critical process status is to be notified. However, only 60 °C can be achieved without danger. In this case, the device would be ordered with a "teach-offset" of +20 °C. At 60 °C in the process, a switching value of 80 °C would then be stored during "teaching".

The ETK12-S limit switch can be used to monitor minima or maxima or maxima.

With a minimum-switch, falling below the limit value causes a switchover to the alarm state. Return to the normal state occurs when the limit value plus the set hysteresis is once more exceeded.

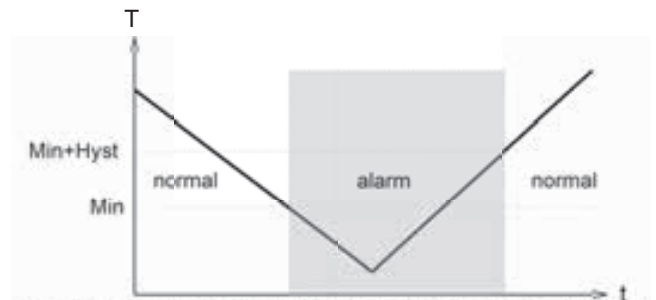

With a maximum-switch, exceeding the limit value causes a switchover to the alarm state. Return to the normal state occurs when the measured value once more falls below the limit value minus the set hysteresis.

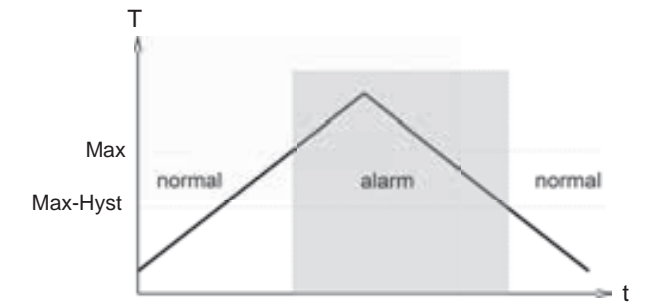

A switchover delay time (t_{DS}) can be applied to the switchover to the alarm state. Equally, one switch-back delay time (t_{DR}) of several can be applied to switching back to the normal state.



In the normal state the integrated LED is on, in the alarm state it is off, and this corresponds to its status when there is no supply voltage.

In the non-inverted (standard) model, while in the normal state the switching output is at the level of the supply voltage; in the alarm

state it is at 0 V, so that a wire break would also display as an alarm state at the signal receiver. Optionally, an inverted switching output can also be provided, i.e. in the normal state the output is at 0 V, and in the alarm state it is at the level of the supply voltage.

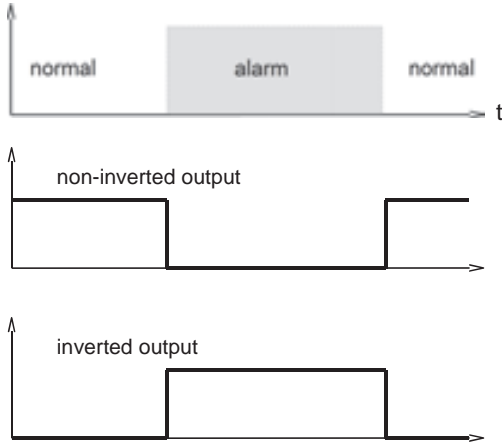

A Power-On-Delay function (ordered as a separate option) makes it possible to maintain the switching output in the normal state for a defined period after application of the supply voltage.

Ordering code

ETK12 - 1. 2. 3. 4. 5. 6.
S [] K1 [] [] [] [] []

○=Option

| | |
|-------------------------------|--|
| 1. Switch | |
| S | push-pull switch (compatible with PNP and NPN) |
| 2. Sensor length L = | |
| 100 | 123 mm |
| 150 | 173 mm |
| 200 | 223 mm |
| 3. Connection material | |
| K1 | stainless steel 1.4571 |
| 4. Programming | |
| N | cannot be programmed (no teaching) |
| P | <input type="radio"/> programmable (teaching possible) |
| 5. Switch type | |
| L | minimum-switch |
| H | maximum-switch |
| 6. Output | |
| O | non-inverted output |
| I | <input type="radio"/> inverted output |

Options

- Switching delay period (0.0..99.9 s) [][] . [] s (from Normal to Alarm)
- Switch-back delay period (0.0..99.9 s) [][] . [] s (from Alarm to Normal)
- Power-On delay period (0..99 s) [][] s
- Switching output fixed at [][] °C
- Switching hysteresis [][] %
- Standard = 2 % of the metering range
- Teach-offset (-100..+100 °C) [][][] °C
- Standard = 0 °C

Further options available on request.

Accessories

- Screwed connections
- Weld-on adapter
- Cable/round plug connector (KB...) see additional information "Accessories"
- Device configurator ECI-3
- Connection cable

Temperature Transmitter / Switch FLEX-T



- Analog 4..20 mA or 0..10 V output signal
- Programmable switching output (push-pull) or alternatively frequency output
- Switching point or full scale can be set via a magnet clip
- Programming protection by removal of the clip
- All metal housing
- Rotatable electronic head for alignment of the 90° cable outlet
- LED for switching status display
- Oil-filled tropical model
- High temperature model (200 °C) optionally available
- IP 67

Characteristics

The temperature sensor consists of a platinum resistance sensor and the downstream evaluation electronics.

The sensors work with a 16-bit processor, a 12-bit A/D and a 12-bit D/A converter. Linearisations and calibrations are carried out automatically. The flash memory guarantees the exchangeability of all programs.

An analog output (4..20 mA or 0..10 V) and a switching output (transistor output "push-pull") are available as output. The switching output can be configured either as a limit switch (minimum / maximum monitoring) or as a frequency output (max. 2 kHz).

Options allow:

- Variable ranges for the analog outputs
- Variable hysteresis
- Minimum or maximum switches
- Inversion of the outputs
- Power-On delay
- Switching delays

Technical data

| | | |
|-----------------------------|--|---|
| Sensor | platinum resistance sensor | |
| Process connection | male thread G 1/4 A.. G 1/2 A, union nut G 3/4 or Tri-clamp connection | |
| Metering range | 0..100 °C | standard range |
| | 0..200 °C | extended range for lance shape with gooseneck |
| | range -20..+200 °C or partial ranges available on request | |
| Measurement accuracy | ±1 % FS | |
| Reproducibility | ±0.1 % FS | |

| | | |
|--------------------------------------|--|-----------------|
| Dynamic (t) | 3 s | |
| | | |
| Pressure | Lance shape
Compact construction | PN 25
PN 100 |
| Medium temperature | as metering range | |
| Ambient temperature | 0..70 °C | |
| Storage temperature | -20..+80 °C | |
| Materials medium-contact | 1.4571 | |
| Materials, non-medium-contact | 1.4305, PP | |
| Supply voltage | 18..30 V DC | |
| Analog output | 4..20 mA / max. load 500 Ω or 0..10 V / min. load 1 kΩ | |
| Switching output | Push-pull (can be connected as PNP or NPN), optionally NPN o.c., configurable as limit switch or frequency output (max. 2 kHz) | |
| Output current | max. 100 mA | |
| Electrical connection | for round plug connector M12x1, 4-pole | |
| Ingress protection | IP 67 | |
| Weight | approx. 0.25 kg | |
| Conformity | CE | |

Wiring

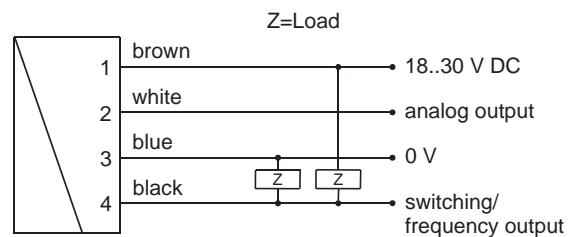

Connection example: PNP NPN

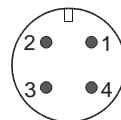

The use of shielded cabling is recommended.

Dimensions

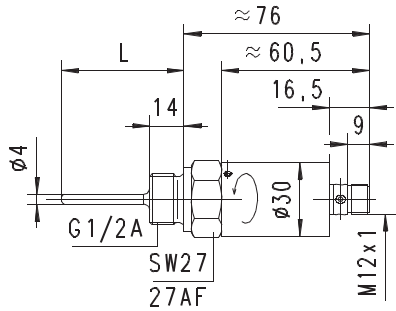

Lance shape

| Lance type | Length X | Screw-in thread |
|------------|----------|-----------------|
| ..050.. | 50 | G 1/2 A |
| ..100.. | 100 | G 1/2 A |
| ..150.. | 150 | G 1/2 A |
| ..200.. | 200 | G 1/2 A |

Compact sensor

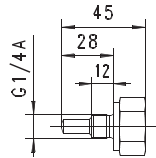

Screw-in sensor G 1/4 A
Type ..028..

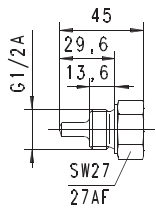

Screw-in sensor G 1/2 A
Type ..029..

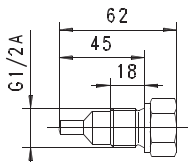

Screw-in sensor G 1/2 A
Type ..045..

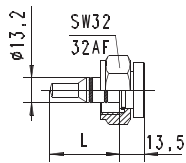

Sensor with union nut for
T-piece G 3/8..G 1/2
Type ..031.. (L = 31 mm)
or
T-piece G 3/4..G 2
Type ..037.. (L = 37 mm)

"Gooseneck" option for higher temperatures
(available for lance and compact shape)

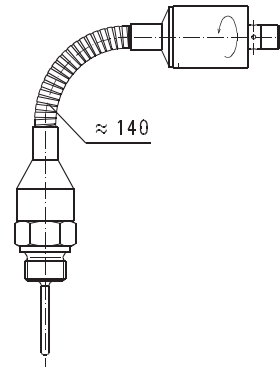

Handling and operation

Note

The sensors are fully preconfigured at HONSBERG to customer wishes. However, as an option, the setting of one or more parameters using a magnetic clip through the enclosed housing (IP 67) is fully possible.

The parameters available are:

- Switching temperature of the limit switch
- Temperature at full scale analog output
- Temperature at full scale frequency output

The parameter to be programmed must be specified when ordering.

Installation

Sensors with screw-in threads are screwed into a T-piece or a nozzle in the pipework, using a suitable flat seal (e.g. Klingerit). Sensors with a union nut are mounted in a T-piece (see separate product information). Use only a hexagonal spanner to tighten. It should be ensured that the sensor tip is located fully in the medium, and does not push against the wall of the pipe. The upper part of the sensor with the connector outputs can be turned steplessly in order to align the cable outlet.

Operation and programming

The electronics contain a magnetic contact, with the aid of which different parameters can be programmed. Programming takes place when a magnet clip is applied for a period between 0.5 and 2 seconds to the marking located on the label. If the contact time is longer or shorter than this, no programming takes place (protection against external magnetic fields).



After the programming ("teaching"), the clip can either be left on the device, or removed to protect data.

The device has a yellow LED which flashes during the programming pulse. During operation, the LED serves as a status display for the switching output.

In order to avoid the need to transit to an undesired operating status during "teaching", the device can be provided ex-works with a "teach-offset". The "teach-offset" value is added to the currently measured value before saving (or is subtracted if a negative value is entered).

Example: The switching value is to be set to 70 % of the metering range, because at this flow rate a critical process status is to be notified. However, only 50% can be achieved without danger. In this case, the device would be ordered with a "teach-offset" of +20 %. At 50 % in the process, a switching value of 70 % would then be stored during "teaching".

Normally, programming is used to set the limit switch. However, if desired, other parameters such as the end value of the analog or frequency output may also be set.

The limit switch can be used to monitor minima or maxima.

With a minimum-switch, falling below the limit value causes a switchover to the alarm state. Return to the normal state occurs when the limit value plus the set hysteresis is again exceeded.

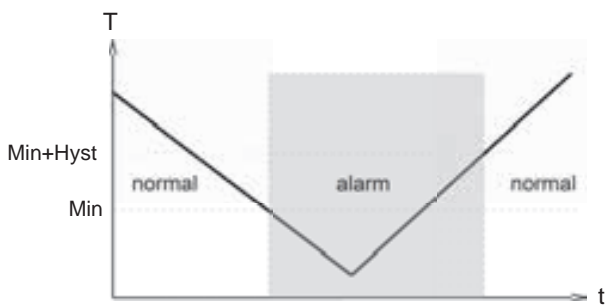

With a maximum-switch, exceeding the limit value causes a switchover to the alarm state. Return to the normal state occurs when the measured value once more falls below the limit value minus the set hysteresis.

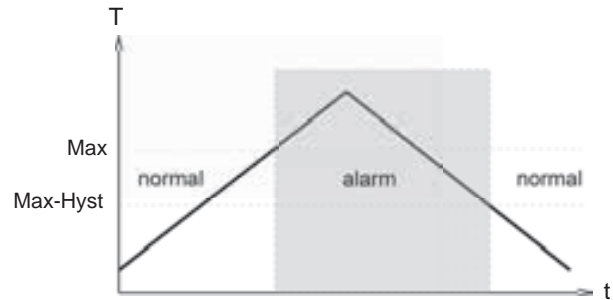

A switchover delay time (t_{DS}) can be applied to the switchover to the alarm state. Equally, one switch-back delay time (t_{DR}) of several can be applied to switching back to the normal state.



In the normal state the integrated LED is on, in the alarm state it is off, and this corresponds to its status when there is no supply voltage.

In the non-inverted (standard) model, while in the normal state the switching output is at the level of the supply voltage; in the alarm state it is at 0 V, so that a wire break would also display as an alarm state at the signal receiver. Optionally, an inverted switching output can also be provided, i.e. in the normal state the output is at 0 V, and in the alarm state it is at the level of the supply voltage.

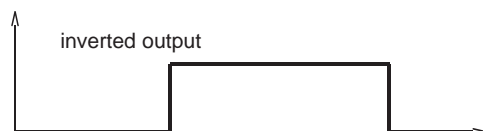
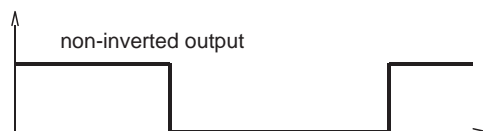

A Power-On delay function (ordered as a separate option) makes it possible to maintain the switching output in the normal state for a defined period after application of the supply voltage.

Ordering code

FLEX-T - 1. 2. 3. 4. 5. 6. 7.
 K

Option =

| | | |
|-------------------------------|----------------------------|---------------------------------------|
| 1. Connection material | | |
| K | stainless steel 1.4571 | |
| 2. Connection size | | |
| 008 | <input type="radio"/> | connection G 1/4 A |
| 013 | | connection for T-piece |
| 015 | | connection for G 1/2 A |
| 3. Process connection | | |
| 050 | lance length | 50 mm Ø 4 mm |
| 100 | | 100 mm Ø 4 mm |
| 150 | | 150 mm Ø 4 mm |
| 200 | | 200 mm Ø 4 mm |
| 028 | sensor length | 28 mm (G 1/4 A) |
| 029 | | 29.6 mm (G 1/2 A) |
| 045 | | 45 mm (G 1/2 A) |
| 031 | sensor for | T-piece G 3/8..G 1/2 |
| 037 | | T-piece G 3/4..G 2 |
| 4. Analog output | | |
| I | current output 4..20 mA | |
| U | voltage output 0..10 V | |
| K | no analog output | |
| 5. Switching output | | |
| T | switching output push-pull | |
| M | <input type="radio"/> | switching output NPN (open collector) |
| K | no switching output | |
| 6. Switching function | | |
| L | minimum-switch | |
| H | maximum-switch | |
| R | frequency output | |
| K | no switching output | |
| 7. Switching signal | | |
| O | standard output | |
| I | inverted output | |

Options

For analog output:

Special range for analog output:

Start of metering range (4 mA or 0 V) at °C
Standard = 0 °C

End of metering range (20 mA or 10 V) at °C

For frequency output:

End frequency (max. 2000 Hz) Hz
Standard = 2000 Hz

Special range for frequency output:

Start of metering range (0 Hz) at °C
Standard = 0 °C

End of metering range (end frequency) at °C
Standard = 100 °C

For switching output:

Switching delay period (0.0..99.9 s) . s
 (from Normal to Alarm)

Switch-back delay period (0.0..99.9 s) . s
 (from Alarm to Normal)

Switching output fixed at °C
Switching hysteresis %

Standard = 2 % of the metering range

General:

Power-On delay period (0..99 s) s
Teach-offset (-20..+200 °C) °C
Standard = 0 °C

High temperature model (Gooseneck)

Tropical model (oil filled)

Accessories

- T-piece type TS-2... Thread G 3/8..G 2
- Cable/round plug connector (KB...) see additional information "Accessories"
- Evaluation electronics OMNI-TA
- Device configurator ECI-3

Temperature Transmitter / Switch OMNI-T



- Analog output 4..20 mA or 0..10 V
- Two programmable switches (push-pull)
- Backlit graphical LCD-Display (transreflective), can be read in sunlight and in the dark
- Programmable parameters via rotatable, removable ring (programming protection)
- Full metal housing with non-scratch, chemically resistant glass
- Physical unit in the display (selectable)
- Rotatable electronic head for best reading position
- Tropical model optionally available
- High temperature model (200 °C) optionally available
- Connection to USB interface for setting parameters
- IP 67

Characteristics

The primary sensor consists of a platinum resistance sensor using thin film technology, which provides a very good response time, thanks to the lance diameter of 4 mm.

With these sensors, switching points can be set on the spot for where process values are exceeded or fallen short of. This setting can be carried out via the display, even without the process. The present values, or error messages from the measuring point, are visible at all times, and all important parameters can be displayed locally (this saves time during installation, commissioning, and troubleshooting during the process). The analog current signal can be evaluated from large distances, and the present values can be made available there. The sensor is configured to your requirements. It is therefore ready for immediate use, without programming. If you wish to change parameters, you can set the device directly at the sensor, by means of the programming ring.

The entire family of OMNI sensors is made up in a modular way, by means of a building-block system (hardware and software). A 16-bit microcontroller with a 12-bit A/D converter and a 12-bit D/A converter ensures the necessary processing speed and accuracy. The signal is displayed with the unit of measure by a backlit LCD graphical display, and is converted into a 0/4..20 mA signal. Two switching points with push-pull output can be programmed across the whole range. The hysteresis of the switching points can be set separately in value and direction (min., max. switching value). Exceeding or falling short of switching points, and error messages, are indicated by a flashing red LED visible from a long distance, together with a message in the display.

Further parameters can be modified by means of a code:

- Signal filter
- Unit (°C, °F ...) incl. automatic conversion of the values
- Output 0 or 4..20 mA
- Value assignment of 0/4 and 20 mA (setting of zero point and range).

By turning the programming ring to right or left, it is simple to modify the parameters (e.g. switching point, hysteresis...). To protect from unintended programming, it can be removed, turned through 180 ° and replaced, or completely removed.



Technical data

| | | |
|--------------------------------------|--|---|
| Sensor | platinum resistance sensor | |
| Process connection | male thread G 1/4 A.. G 1/2 A, union nut G 3/4 or Tri-clamp connection | |
| Metering range | 0..100 °C | standard range |
| | 0..200 °C | extended range for lance shape with gooseneck |
| Measurement accuracy | ±1 % FS | |
| Reproducibility | ±0.1 % FS | |
| Dynamics | measuring cycle 31.25 ms, display cycle 0.5 sec. | |
| Dynamic (τ) | 3 s | |
| | | |
| Operating pressure | Lance shape | PN 25 |
| | Compact construction | PN 100 |
| Medium temperature | same as metering range | |
| Ambient temperature | -20..+70 °C | |
| Storage temperature | -20..+80 °C | |
| Materials medium-contact | 1.4571 | |
| Materials, non-medium-contact | 1.4305, hardened mineral glass, samarium-Cobalt, | |
| Supply voltage | 18..30 V DC | |
| Power consumption | < 1 W | |
| Analog output | 0/4..20 mA
0/2..10 V via a 500 Ohm resistance to 0 V | |
| Switching outputs S1 and S2 | transistor output "push-pull" (short circuit proof and reverse polarity protected) I _{out} = 100 mA max. per output | |

| | |
|---------------------------|---|
| Display | backlit graphical LCD-Display (transreflective), extended temperature range -20..+70 °C, 32 x 16 pixels, background illumination, displays value and unit, flashing LED signal lamp with simultaneous message on the display. |
| Ingress protection | IP 67 |
| Weight | approx. 0.35 kg |
| Conformity | CE |

Dimensions

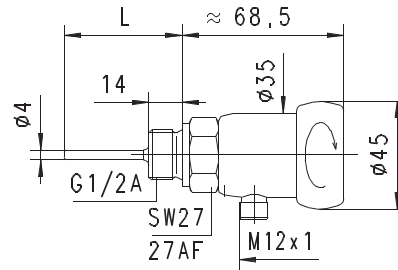

| Lance type | Length X | Screw-in thread |
|------------|----------|-----------------|
| ..050.. | 50 | G 1/2 A |
| ..100.. | 100 | G 1/2 A |
| ..150.. | 150 | G 1/2 A |
| ..200.. | 200 | G 1/2 A |

Wiring

Z = Load

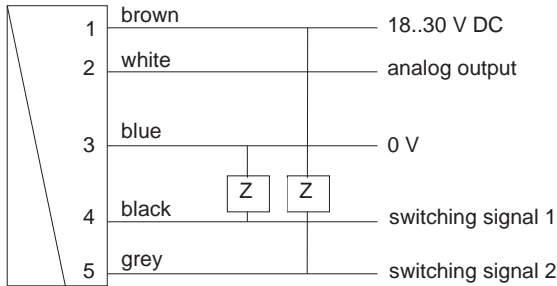

connection example PNP NPN

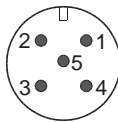

Round plug connector M12x1

The switching outputs are self-configuring, depending on whether they are connected as PNP or NPN switches (push-pull).

It is recommended to use shielded wiring. Conversion of a 0/4..20 mA output into a 0/2..10 V output:

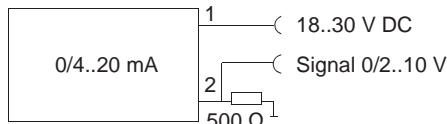

True 0..10 V output can also be ordered.

Compact sensor

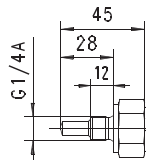

Screw-in sensor G 1/4 Type ..028..

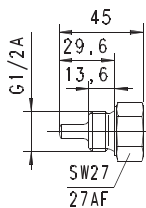

Screw-in sensor G 1/2 Type ..029..

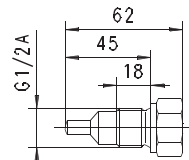

Screw-in sensor G 1/2 Type ..045..

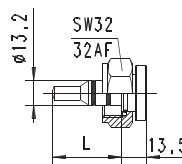

Sensor with union nut for T-piece G 3/8..G 1/2 Type ..031.. (L = 31 mm) or T-piece G 3/4..G 2 Type ..037.. (L = 37 mm)

"Gooseneck" option for higher temperatures
(available for lance and compact shape)



Handling and operation

Installation

Sensors with screw-in threads are screwed into a T-piece or a nozzle in the pipework, using a suitable flat seal (e.g. Klingerit). Sensors with a union nut are mounted in a T-piece (see separate product information). Use only a hexagonal spanner to tighten. It should be ensured that the sensor tip is located fully in the medium, and does not push against the wall of the pipe. The upper part of the sensor with the connector outputs can be turned steplessly in order to align the cable outlet.

Operation and programming

The annular gap of the programming ring can be turned to positions 1 and 2. The following actions are possible:



Set to 1 = continue (STEP)
Set to 2 = modify (PROG)

Neutral position between 1 and 2

The ring can be removed to act as a key, or turned through 180 ° and replaced to create a programming protector. Operation is by dialog with the display messages, which makes its use very simple. Starting from the normal display (currently measured value with unit), if 1 (STEP) is repeatedly selected, then the display shows the following information in this order:

Display of the parameters, using position 1

- Switching value S1 (switching point 1 in the selected unit)
- Switching characteristic of S1
(MIN = monitoring of minimum value, hysteresis greater than switching value,
MAX = monitoring of maximum value, hysteresis less than switching value)
- Hysteresis 1 (hysteresis value of S1 in the set unit)
- Switching value S2
- Switching characteristic of S2
- Hysteresis 2
- Code:
- After entering the code 111, further parameters can be defined:
- Filter (settling time of the display and output)
- Units: e.g. ° C or ° F
- Output: 0..20 mA or 4..20 mA
- 0/4 mA (temperature corresponding to 0/4 mA)
- 20 mA (temperature corresponding to 20 mA)

Edit, using position 2

If the currently visible parameter is to be modified:

- Turn the annular gap to position 2, so that a flashing cursor appears which displays the position which can be modified.
- By repeatedly turning to position 2, values are increased; by turning to position 1, the next digit is then reached.
- If there is no action within 30 seconds, the device returns to the normal display range without accepting the modification.
- Leaving the parameter by turning to position 1 means that the modification is accepted

The limit switches S1 and S2 can be used to monitor minima or maxima.

With a minimum-switch, falling below the limit value causes a switchover to the alarm state. Return to the normal state occurs when the limit value plus the set hysteresis is once more exceeded.

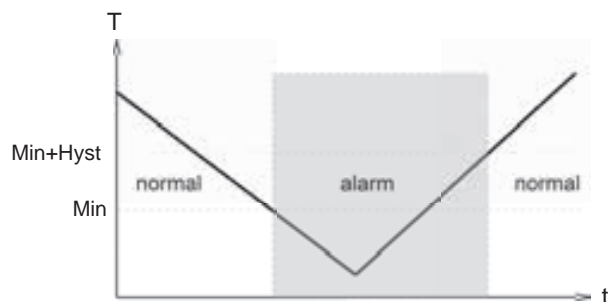

With a maximum-switch, exceeding the limit value causes a switchover to the alarm state. Return to the normal state occurs when the measured value once more falls below the limit value minus the set hysteresis.

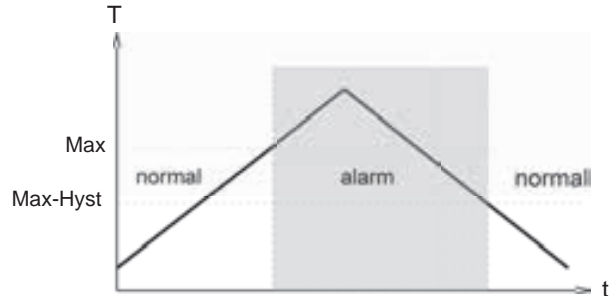

The change to the alarm state is indicated by the integrated red LED and a cleartext in the display.

While in the normal state, the switching outputs are at the level of the supply voltage; in the alarm state they are at 0 V, so that a wire break would also be displayed as an alarm state at the signal receiver.

Simulation mode

To simplify commissioning, the sensor supports a simulation mode for the analog output. It is possible to create a programmable value in the range 0..26.0 mA at the output (without modifying the process variable). This allows the wiring run between the sensor and the downstream electronics to be tested during commissioning. This mode is accessed by means of **Code 311**.

Zero point alignment

Zero point alignment by customer: Immerse the lance completely into ice/water at 0 °C; after 5 minutes use **Code 211** to carry out the automatic zero point correction. The sensor shifts the complete characteristic curve, based on the new zero point.

Overload display

Overload of the switching outputs, e.g. because of a short circuit, is detected, indicated on the display, and the affected switching output is set to high impedance. After the short circuit has been corrected, the switching output continues to function.

Default setting

After setting the configuration parameters, they can be reset to factory values at any time, by means of **Code 989**.

Ordering code

OMNI-T - 1. 2. 3. 4. 5. 6. 7.

Option =

| | | | |
|---------------------------------|--|--|-----|
| 1. Metering range | | | |
| 100 | range 0..100 °C | | |
| 200 | range 0..200 °C | | |
| 2. Connection material | | | |
| K | stainless steel 1.4571 | | |
| 3. Connection size | | | |
| 008 | connection G 1/4 A | | |
| 013 | connection for T-piece | | |
| 015 | connection for G 1/2 A | | |
| 4. Signaloutput | | | |
| I | 0/4..20 mA current output | | |
| U | <input type="radio"/> 0/2..10 V voltage output | | |
| 5. Electronic connection | | | |
| S | for round plug connector M12x1, 5-pole | | |
| 6. Process connection | | | |
| 050 | lance length | 50 mm Ø 4 mm | ● ● |
| 100 | | 100 mm Ø 4 mm | ● ● |
| 150 | | 150 mm Ø 4 mm | ● ● |
| 200 | | 200 mm Ø 4 mm | ● ● |
| 028 | sensor length | 28 mm (G 1/4 A) | ● |
| 029 | | 29.6 mm (G 1/2 A) | ● |
| 045 | | 45 mm (G 1/2 A) | ● |
| 031 | sensor for | T-piece G 3/8..G 1/2 | ● |
| 037 | | T-piece G 3/4..G 2 | ● |
| 7. Option | | | |
| H | <input type="radio"/> | model with gooseneck for metering range 0..200 °C (only for lance legth) | ● |

Options

- 10 V output
- Range -20..+200 °C

Accessories

- T-piece type TS-2... Thread G 3/8..G 2
- Cable/round plug connector (KB...) see additional information "Accessories"
- Device configurator ECI-3

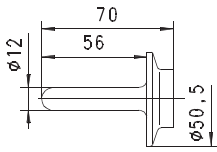

Sensor for Tri-clamp connection
Type ..056..

"Gooseneck" option for higher temperatures
(available for lance and compact shape)

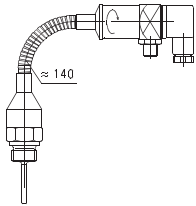

Handling and Operation

Installation

Sensors with screw-in threads are screwed into a T-piece or a nozzle in the pipework, using a suitable flat seal (e.g. Klingerit). Sensors with a union nut are mounted in a T-piece (see separate product information). Use only a hexagonal spanner to tighten. It should be ensured that the sensor tip is located fully in the medium flow, and does not push against the wall of the pipe. After this, the upper part of the sensor with the connector output can be turned steplessly in order to align the cable outlet.

Ordering code

Sensors ETSD1 and ETSD2 are what you should order for a complete temperature difference measuring point!

ETSD - 1. 2. 3. 4. 5. 6.

| | |
|--------------------------------|--|
| 1. Zero point | |
| 04 | Output current in mA, which corresponds to T1-T2 = 0 K (for curve A always 0, for curve B selectable in the range of 04 to 12) |
| 2. Difference | |
| 020 | T1-T2 = 20 Kelvin corresponds to 20 mA |
| 050 | T1-T2 = 50 Kelvin corresponds to 20 mA |
| 3. Connection material | |
| K | Stainless steel 1.4571 |
| 4. Connection type | |
| 050 | 50 mm Ø 4 mm |
| 100 | 100 mm Ø 4 mm |
| 150 | Lance length 150 mm Ø 4 mm |
| 200 | 200 mm Ø 4 mm |
| 028 | 28 mm (G ¼ A) |
| 029 | 29.6 mm (G ½ A) |
| 045 | 45 mm (G ½ A) |
| 031 | T-piece G ¾..G ½ |
| 037 | Sensor for T-piece G ¾..G 2 |
| 5. Characteristic curve | |
| A | Version A (output signal proportional to T1-T2) |
| B | Version B (output signal proportional to T1-T2) |
| 6. Option | |
| H | Gooseneck model |

Accessories

- T-piece type TS-2... Thread G ¾..G 2
- Cable/round plug connector (KB...) see additional information "Accessories"
- Evaluation electronics OMNI-TA
- Device configurator ECI-2

Temperature Difference Transmitter ETSD



- Simple measurement of temperature differences
- Self-built plug including
- large distance between the two sensors is possible (4-wire connection)
- Infinitely adjustably rotatable cable outlet for clean alignment
- Different characteristic curves are possible

Characteristics

Temperature difference measuring at two process locations, with very low installation effort and compliant 4..20 mA 2-wire system. The ETSD1 und ETSD2 sensors measure temperatures T1 and T2 at the respective process locations, each using a platinum resistance sensor. In addition to the sensor, ETSD1 contains a microcontroller circuit which calculates the difference between the two temperatures (T1-T2), and outputs it via an amplifier as a 4..20 mA signal. Two outputs with different characteristic curves are available as standard. Altogether the circuit requires < 4 mA, and so it was possible to implement a 2-wire system (including wire break recognition).

Technical data

| | | |
|--------------------------------------|--|---|
| Sensor | platinum resistance sensor | |
| Process connection | male thread G 1/4 A.. G 1/2 A, union nut G 3/4 or 3-clamp connection | |
| Metering range | ±020 K, ±50 K (other on request) | |
| Measurement accuracy | ±1 K | |
| Reproducibility | ±0.1 K | |
| Pressure | Lance shape | PN 25 |
| | Compact construction | PN 100 |
| Media temperature T1 | Lance shape | -20..+80 °C
optionally -20..+100 °C with gooseneck |
| | Compact construction | -20..+80 °C
optionally -20..+100 °C with gooseneck |
| Media temperature T2 | Lance shape | -20..+120 °C |
| | Compact construction | -20..+100 °C |
| Ambient temperature | -20..+70 °C | |
| Dynamic (τ) | 3 s | |
| | | |
| Supply voltage | 15..30 V DC | |
| Materials medium-contact | 1.4571 | |
| Materials, non-medium-contact | CW614N plated, PP | |
| Analog output | 4..20 mA (two-wire) | |
| Reversal polarity protected | yes | |
| Electrical connection | plug DIN 43650-A / ISO 4400 | |
| Ingress protection | IP 65 | |
| Weight | 0.45 kg | |
| Conformity | CE | |

Ranges

Metering ranges of 20 Kelvin difference and 50 Kelvin difference are available as standard. Any other required differences are available on request.
Every temperature difference range is available with two different characteristic curves:
Characteristic curve A: The absolute value of the difference T1-T2 is output, i.e. it cannot be recognised from the signal which of the two temperatures is the higher. Difference 0 corresponds to 4 mA. If the maximum difference is exceeded, the output signal can show larger values than 20 mA (max. 24 mA).

Example:
Characteristic curve A for metering range 20 Kelvin difference

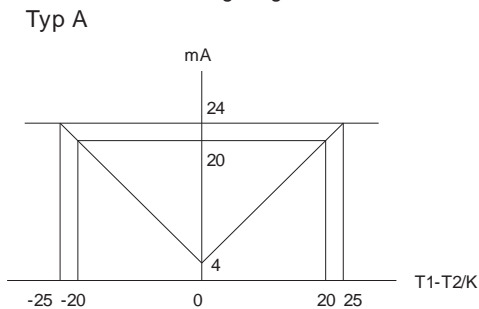

Characteristic curve B: The output signal is proportional to the difference T1-T2. The difference 0 Kelvin can be assigned to any desired current value in the range 4..20 mA, so that negative differences can also be represented.

If the intended metering range is left, the output signal can show smaller values than 4 mA (min. 3.6 mA) or larger values than 20 mA (max. 21 mA).

Example:
Characteristic curve B for metering range 20 Kelvin difference
Difference of 0 Kelvin corresponds to 4 mA

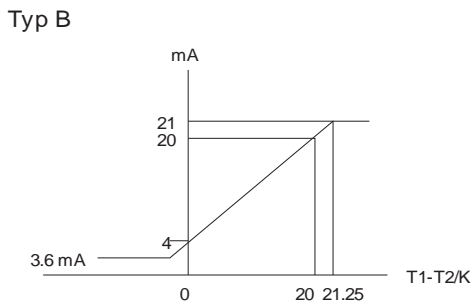

Wiring

plug DIN 43650-A / ISO 440 round plug connector M12x1

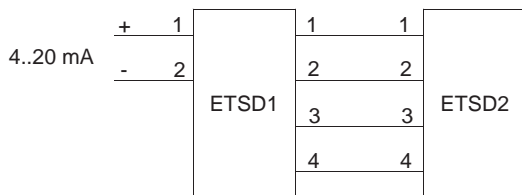

Dimensions

Lance shape

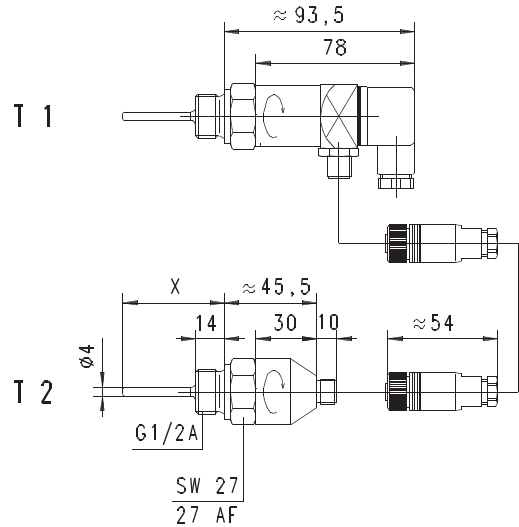

| Lance type | Length X | Screw-in thread |
|------------|----------|-----------------|
| ..050.. | 50 | G 1/2 A |
| ..100.. | 100 | G 1/2 A |
| ..150.. | 150 | G 1/2 A |
| ..200.. | 200 | G 1/2 A |

Compact sensor

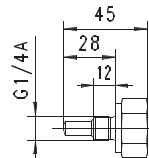

Screw-in sensor G 1/4 A
Type ..028..

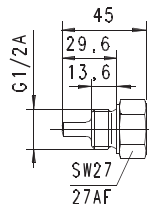

Screw-in sensor G 1/2 A
Type ..029..

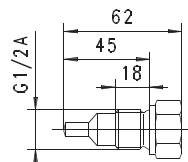

Screw-in sensor G 1/2 A
Type ..045..

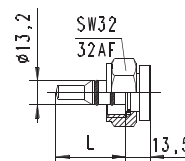

Sensor with union nut for
T-piece G 3/8..G 1/2
Type ..031.. (L = 31 mm)
or
T-piece G 3/4..G 2
Type ..037.. (L = 37 mm)

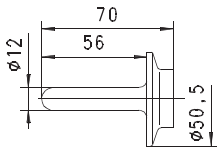

Sensor for Tri-clamp connection
Type ..056..

"Gooseneck" option for higher temperatures
(available for lance and compact shape)

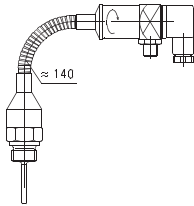

Handling and Operation

Installation

Sensors with screw-in threads are screwed into a T-piece or a nozzle in the pipework, using a suitable flat seal (e.g. Klingerit). Sensors with a union nut are mounted in a T-piece (see separate product information). Use only a hexagonal spanner to tighten. It should be ensured that the sensor tip is located fully in the medium flow, and does not push against the wall of the pipe. After this, the upper part of the sensor with the connector output can be turned steplessly in order to align the cable outlet.

Ordering code

Sensors ETSD1 and ETSD2 are what you should order for a complete temperature difference measuring point!

ETSD - 1. 2. 3. 4. 5. 6.

| | |
|--------------------------------|--|
| 1. Zero point | |
| 04 | Output current in mA, which corresponds to T1-T2 = 0 K (for curve A always 0, for curve B selectable in the range of 04 to 12) |
| 2. Difference | |
| 020 | T1-T2 = 20 Kelvin corresponds to 20 mA |
| 050 | T1-T2 = 50 Kelvin corresponds to 20 mA |
| 3. Connection material | |
| K | Stainless steel 1.4571 |
| 4. Connection type | |
| 050 | 50 mm Ø 4 mm |
| 100 | 100 mm Ø 4 mm |
| 150 | Lance length 150 mm Ø 4 mm |
| 200 | 200 mm Ø 4 mm |
| 028 | 28 mm (G ¼ A) |
| 029 | 29.6 mm (G ½ A) |
| 045 | 45 mm (G ½ A) |
| 031 | T-piece G ¾..G ½ |
| 037 | Sensor for T-piece G ¾..G 2 |
| 5. Characteristic curve | |
| A | Version A (output signal proportional to T1-T2) |
| B | Version B (output signal proportional to T1-T2) |
| 6. Option | |
| H | Gooseneck model |

Accessories

- T-piece type TS-2... Thread G ¾..G 2
- Cable/round plug connector (KB...) see additional information "Accessories"
- Evaluation electronics OMNI-TA
- Device configurator ECI-2

Temperature Difference Transmitter ETSD



- Simple measurement of temperature differences
- Self-built plug including
- large distance between the two sensors is possible (4-wire connection)
- Infinitely adjustably rotatable cable outlet for clean alignment
- Different characteristic curves are possible

Characteristics

Temperature difference measuring at two process locations, with very low installation effort and compliant 4..20 mA 2-wire system. The ETSD1 und ETSD2 sensors measure temperatures T1 and T2 at the respective process locations, each using a platinum resistance sensor. In addition to the sensor, ETSD1 contains a microcontroller circuit which calculates the difference between the two temperatures (T1-T2), and outputs it via an amplifier as a 4..20 mA signal. Two outputs with different characteristic curves are available as standard. Altogether the circuit requires < 4 mA, and so it was possible to implement a 2-wire system (including wire break recognition).

Technical data

| | | |
|--------------------------------------|--|---|
| Sensor | platinum resistance sensor | |
| Process connection | male thread G 1/4 A.. G 1/2 A, union nut G 3/4 or 3-clamp connection | |
| Metering range | ±020 K, ±50 K (other on request) | |
| Measurement accuracy | ±1 K | |
| Reproducibility | ±0.1 K | |
| Pressure | Lance shape | PN 25 |
| | Compact construction | PN 100 |
| Media temperature T1 | Lance shape | -20..+80 °C
optionally -20..+100 °C with gooseneck |
| | Compact construction | -20..+80 °C
optionally -20..+100 °C with gooseneck |
| Media temperature T2 | Lance shape | -20..+120 °C |
| | Compact construction | -20..+100 °C |
| Ambient temperature | -20..+70 °C | |
| Dynamic (τ) | 3 s | |
| | | |
| Supply voltage | 15..30 V DC | |
| Materials medium-contact | 1.4571 | |
| Materials, non-medium-contact | CW614N plated, PP | |
| Analog output | 4..20 mA (two-wire) | |
| Reversal polarity protected | yes | |
| Electrical connection | plug DIN 43650-A / ISO 4400 | |
| Ingress protection | IP 65 | |
| Weight | 0.45 kg | |
| Conformity | CE | |

Radio Temperature Transmitter / Switch RF1-T



- Temperature sensor with integrated radio interface for the HONSBERG RF1 radio system
- PT1000 sensor
- Energy-saving battery operation
- Robust stainless steel housing
- Operation without registration or fees (ISM band 868 MHz)
- Ingress protection IP 67

Characteristics

The temperature sensors in this range measure temperatures in liquids and gases. The measured value is polled using a radio connection. If set limit values are exceeded, this can be actively notified by the sensor. To operate one or more sensors, at least one send/receive station (access point RF1-ETH or RF1-USB) is required.

The robust solid metal construction makes the sensors suitable for universal industrial use.

Technical data

| | | |
|--------------------------------------|--|---|
| Sensor | platinum resistance sensor | |
| Process connection | male thread G 1/4 A.. G 1/2 A, union nut G 3/4 or Tri-clamp connection | |
| Metering ranges | 0..100 °C | standard range |
| | 0..200 °C | extended range for lance shape with gooseneck |
| Measurement accuracy | ±0.5 K | |
| Reproducibility | ±0.1 K | |
| Pressure | lance shape | PN 25 |
| | compact construction | PN 100 |
| Ambient temperature | -20..+70 °C | |
| Storage temperature | -20..+80 °C | |
| Materials medium-contact | stainless steel 1.4571 | |
| Materials, non-medium-contact | stainless steel 1.4305 | |
| Voltage supply | lithium battery 1/2 AA 3.6 V (e.g. Tadiran SL-750/S) | |
| Power consumption | depending on parameter settings and operating status, minimum 70 µW | |

| | |
|-----------------------------|--|
| Battery life | depending on parameter settings, usually > 1 year |
| Radio frequency | 868.9 MHz; < 10 mW (ISM band, no registration or fees) |
| Vibration resistance | max. 20 g |
| Ingress protection | IP 67 |
| Conformity | CE (FTEG and directive 1999 / 5 / EC) |

Dimensions

Lance shape

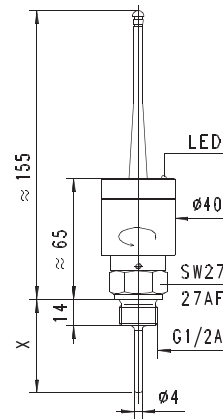

| Lance type | Length X | Screw-in thread |
|------------|----------|-----------------|
| ..050.. | 50 | G 1/2 A |
| ..100.. | 100 | G 1/2 A |
| ..150.. | 150 | G 1/2 A |
| ..200.. | 200 | G 1/2 A |

"Gooseneck" option for higher temperatures

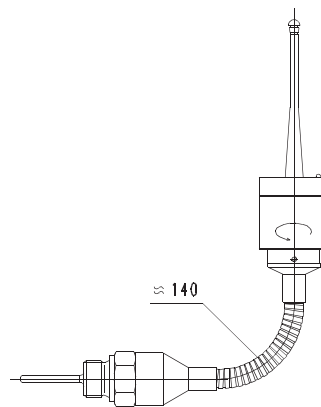

Compact sensor

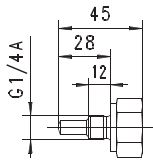

Screw-in sensor G 1/4 A
Type ..028..

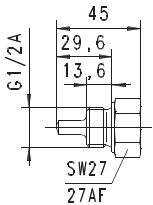

Screw-in sensor G 1/2 A
Type ..029..

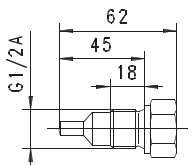

Screw-in sensor G 1/2 A
Type ..045..

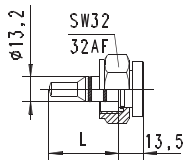

Sensor with union nut for
T-piece G 3/8..G 1/2
Type ..031.. (L = 31 mm)
or
T-piece G 3/4..G 2
Type ..037.. (L = 37 mm)

Handling and operation

Note

The sensor is fitted with a yellow LED, which briefly flashes every 10 s if the battery is operational.

Installation

Sensors with screw-in threads are screwed into a T-piece or a nozzle in the pipework, using a suitable flat seal (e.g. Klingerit). Sensors with a union nut are mounted in a T-piece (see separate product information). Use only a hexagonal spanner to tighten. It should be ensured that the sensor tip is located fully in the medium, and does not push against the wall of the pipe.

Operation and programming

If the customer desires, the sensor can be preconfigured and made ready for use, with the battery inserted. Configuration before commissioning is then unnecessary. However, all parameters can be modified by radio using the optionally available software RF1-Control.

Modifiable parameters include:

- Measurement cycle time
- Limit values for alarm warnings
- Metering range

Thanks to the flash memory used, the firmware can also be updated by radio if necessary. Software modules can be made available by HONSBERG for customer applications; this allows the use of the whole range of functionality.

Detailed information available on request.

Changing battery

The cover of the housing is unscrewed to change the battery. The battery can be replaced without the need for additional tools. Take care when removing the lid: Do not tear off the wiring! Remove the battery from the battery holder, and replace it with a suitable battery (e.g. Tadiran Lithium SL-750/S). If the battery is connected with reversed polarity, it will be discharged, but the device will not be damaged.

Ordering code

RF1-T - 1. 2. 3. 4. 5.
 K

Option =

| | | | | | |
|-------------------------------|--------------------------|---|----------------------|--------------------------|--------------------------|
| 1. Metering range | | | | | |
| 100 | <input type="checkbox"/> | metering range 0..100 °C | | | |
| 200 | <input type="radio"/> | metering range 0..200 °C | | | |
| 2. Connection material | | | | | |
| K | <input type="checkbox"/> | stainless steel 1.4571 | | | |
| 3. Connection size | | | | | |
| 008 | <input type="checkbox"/> | connection G 1/4 A | | | |
| 013 | <input type="checkbox"/> | connection for T-piece | | | |
| 015 | <input type="checkbox"/> | connection for G 1/2 A | | | |
| 4. Process connection | | | | | |
| 050 | <input type="checkbox"/> | lance length | 50 mm Ø 4 mm | <input type="checkbox"/> | <input type="checkbox"/> |
| 100 | <input type="checkbox"/> | | 100 mm Ø 4 mm | <input type="checkbox"/> | <input type="checkbox"/> |
| 150 | <input type="checkbox"/> | | 150 mm Ø 4 mm | <input type="checkbox"/> | <input type="checkbox"/> |
| 200 | <input type="checkbox"/> | | 200 mm Ø 4 mm | <input type="checkbox"/> | <input type="checkbox"/> |
| 028 | <input type="checkbox"/> | sensor length | 28 mm (G 1/4 A) | <input type="checkbox"/> | <input type="checkbox"/> |
| 029 | <input type="checkbox"/> | | 29.6 mm (G 1/2 A) | <input type="checkbox"/> | <input type="checkbox"/> |
| 045 | <input type="checkbox"/> | | 45 mm (G 1/2 A) | <input type="checkbox"/> | <input type="checkbox"/> |
| 031 | <input type="checkbox"/> | sensor for | T-piece G 3/8..G 1/2 | <input type="checkbox"/> | <input type="checkbox"/> |
| 037 | <input type="checkbox"/> | | T-piece G 3/4..G 2 | <input type="checkbox"/> | <input type="checkbox"/> |
| 5. Option | | | | | |
| H | <input type="radio"/> | model with gooseneck for metering range 0..200 °C | | <input type="checkbox"/> | <input type="checkbox"/> |

Accessories

- T-piece type TS-2... Thread G 3/8..G 2
- Cable/round plug connector (KB...) see additional information "Accessories"
- USB adapter RF1-USB
- Ethernet adapter RF1-ETH

Infrared Thermometer IR-CT 20



- Small infrared measuring head with 20:1 optical resolution
- Freely selectable and scalable analog output
- Robust and applicable without cooling

Characteristics

The infrared transmitter IR-CT 20 is designed for non-contact temperature measurements. The infrared measuring head allows very precise and contact-free measurements.

The infrared thermometer measures the surface temperature of the next visible surface and outputs it as linearized signal (current, voltage or thermocouple J, K).

The device is very robust and is applicable without cooling at ambient temperature up to 180 °C.

Technical data

| | |
|------------------------------------|---|
| Measuring range | : -50..+975 °C
freely scalable via programming buttons |
| Spectral region | : 8..14 μm |
| Optical resolution | : 20:1 (precision glass optics) |
| System accuracy | : ±1 % or ±1 °C (higher value applicable) |
| Reproducibility | : ±0.5 % or 0.05 °C/K
(higher value applicable) |
| Response time | : 150 ms (95 %) |
| Emissions-,
transmission factor | : 0,100..1,100 scalable |
| Output signal | : 0..20 mA, 4..20 mA, 0..5 V, 0..10 V
thermocouple type J or K |
| Output impedance | |
| mA | : max. 500 Ohm (at 8..36 V DC) |
| V | : min. 100 kOhm load resistance |
| Thermocouple | : 20 Ohm |
| Power supply | : 8..36 V DC |
| Power consumption | : max. 100 mA |
| Cable length | : 1 m (atandard), 3 m, 15 m |
| Protection class | : IP65 (NEMA-4) |
| Vibration (measuring head) | |
| IEC 68-2-6 | : 3G, 11..200 Hz, each axis |
| Shock (measuring head) | |
| IEC 68-2-27 | : 50G, 11 ms, each axis |
| Weight | : Meas. head: 40 g, electronics: 420 g |

Working temperature

Measuring head : -20..+180 °C
Electronics : 0..65 °C

Dimensions

Measuring box:

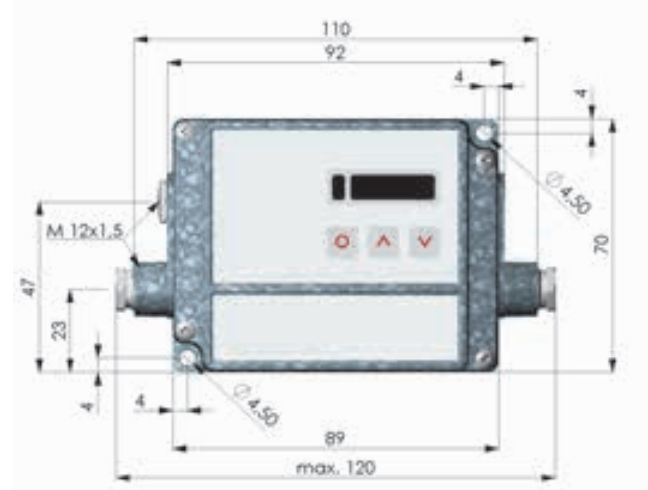

Measuring head:

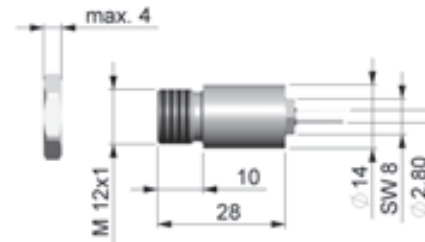

Optical resolution

Optical resolution: standard

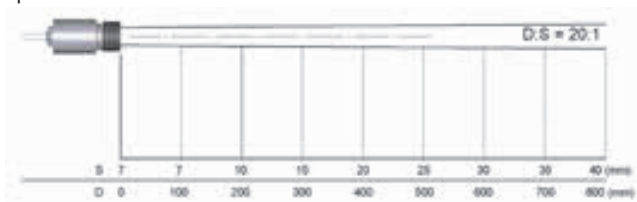

Optical resolution: with option CF (auxiliary lens for measuring smallest objects)

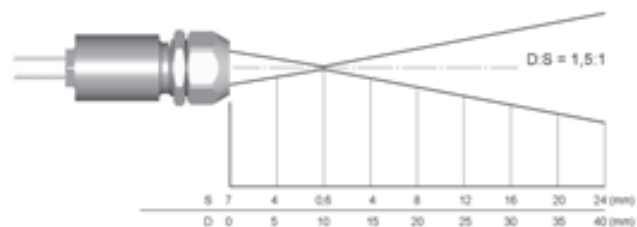

continued on next page

Ordering code

IR-CT20 - 1. - 2.

| 1. Cable length L | |
|-------------------|--|
| L01 | 1 m (standard) |
| L03 | 3 m |
| L15 | 15 m |
| 2. Options | |
| 00 | without option |
| CF | Auxiliary lens for measuring smallest objects
(measuring spot diameter 0.6 mm @ 10 mm,
at long distance 1.5:1) |

Accessories

MW

Mounting bracket, fixed

MB

Mounting bolts with M12x1 thread

MG

Mounting fork, adjustable in 2 axis with M12x1 mount

FVS

Standard air purge collar

FVL

Laminar air purge collar

Head Transmitter T19



Dimensions

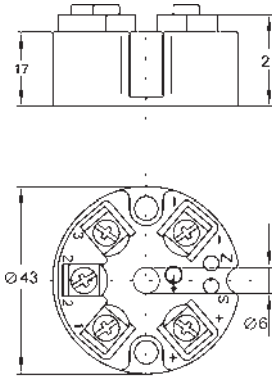

Characteristics

The transmitter T19 makes the field-mounting in the head of a RTD temperature sensor with DIN-head, possible. The current output guarantees a trouble free signal transmission over long distances. Different measuring ranges are configurable by internal links.

Technical data

- Supply voltage : loop powered
- Operating temperature : -40..+85 °C
- relative humidity : < 95 % without condensation
acc. to DIN IEC 68-2-30 Var.2
- Vibration : 10..2000 Hz, 5 g DIN IEC 68-2-6
- Shock : acc. to DIN IEC 68-2-27 g_n = 15
- CE - conformity : EN50 082-2

- Input** : Pt100, DIN IEC 751 2- or 3-wire
- Measuring range : -50..+400 °C
- Temperature coefficient : ± 0.2 K / 10 Ohm, 3-wire
- Max. line resistance : 30 Ohm each line, 3-wire, symmetric
- 0-point adjustment (Z) : type 1P0-1 ±10 °C
type 1P0-2 ±25 °C
type 1P0-3 ±30 °C
- End-value adjustment(S) : approx. 10 % of the end-value

- Output** : 4..20 mA, loop powered
- Accuracy : ± 0.5 %
- Linearisation error : ± 0.1 %
- Circuit error indication
- Broken line : output current < 3 mA
- Cross fault : output current < 3 mA
- Burden : $RA \leq (U_B - 10 \text{ V}) / 0.02 \text{ A}$

- Case**
- Material : Polyamide, with fiber glass
- Weight : approx. 30 g
- Connection : screw terminals, 0.14..1.5 mm²
- Protection class : case IP50, terminals IP 00

Measuring ranges and code for factory configuration

| Pt100 [°C] (Code XX for ordering code field 3) | | | | | |
|--|-----------|------------|-----------|------------|-----------|
| Type 1P0-1 | Code (XX) | Type 1P0-2 | Code (XX) | Type 1P0-3 | Code (XX) |
| -50..+50 | EA | -50..+200 | EL | -30..+30 | CA |
| 0..50 | 1A | 0..200 | 1L | -30..+50 | CB |
| 0..100 | 1E | 0..250 | 1M | 0..60 | 1C |
| 0..120 | 1F | 0..300 | 1N | 0..80 | 1D |
| 0..150 | 1H | 0..350 | 1P | 0..100 | 1E |
| 0..200 | 1L | 0..400 | 1Q | 0..120 | 1F |

Connection diagram

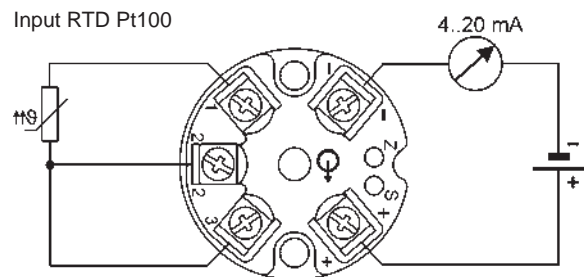

Ordering code

1. 2. 3.
T19-10- 0 - -

| | |
|---------------------------------|----------------------------------|
| 1. Measuring input | |
| 1P | Pt100 |
| 2. Measuring range | |
| 1 | Pt100, -50..+200 °C configurable |
| 2 | Pt100, -50..+400 °C configurable |
| 3 | Pt100, -30..+120 °C configurable |
| 3. Factory configuration | |
| NK | without |
| XX | see table for code |

Analog Head Transmitter T03 BU / WE



- Continuous measurement due to analog signal path
- Measuring range programmable
- 2- or 3- wire sensor connection

Characteristics

The T03 BU / WE is an analog Pt100 transmitter. It is designed for industrial applications and are used to measure the temperature through Pt100 resistance thermometers in 2-/3-wire circuits connections. The 0...10 V output signal is linear with temperature.

The transmitter is factory preset, but can also be configured by the customer via programming tool. This makes customers' warehousing easier and has the advantages of a freely programmable measuring range.

This transmitter combines the advantages of a continuous analog signal path and those of digital adjustment.

Technical data

| | |
|--------------------------------------|---|
| Measuring input | : Pt100 |
| Measuring range | : -200...+850 °C, programmable |
| Measuring span | : 40 to 1050 K |
| Lower range limit | : if span <75 K: -40, -20, 0, 20, 40 °C |
| | : if span =75 K: ±50 °C |
| | : if span >75 K: ±(span*0.2+35 °C) |
| Sensor connection | : 2- or 3-wire connection |
| Measuring rate | : continuous measurement due to analog signal path |
| Output signal | : 0...10 V, 3-wire-technology |
| Transfer accuracy | : ±0.2 % Full Scale |
| Calibration accuracy | : ≤ ±0.2 °C or ±0.2 % of meas. span |
| Power supply U _B | : 15...30 V DC |
| Permissible load R _L | : ≥ 10 kOhm |
| Setting time on a temperature change | : ≤ 10 ms |
| Working temperature | : -40...+85 °C |
| Electrical connection | : via screw terminals
max. cable cross-section 1.75 m ² |
| Housing | : PC-housing, suitable for installation in connection head (DIN 43729 form B) |
| Operating position | : unrestricted |
| Protection class | : housing: IP54
terminals: IP00 |

Dimensions

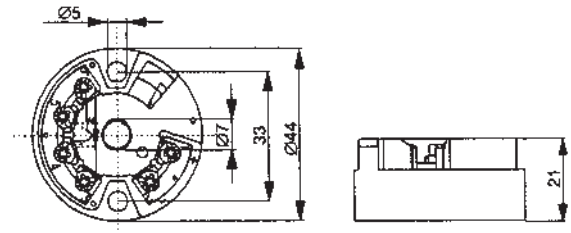

Connection diagram

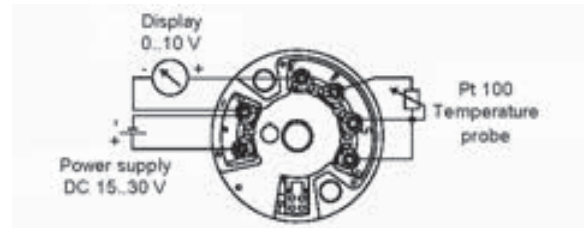

Ordering code

T03BU/WE - 1. - 2.

1. Sensor connection

| | |
|----|--------------------------------------|
| P2 | resistance thermometer Pt100, 2-wire |
| P3 | resistance thermometer Pt100, 3-wire |

2. Measuring range

| | |
|-----|--|
| MBx | state desired measuring range
e.g.: MB -50...+400 °C
(max. possible measuring range: -200...+850 °C) |
|-----|--|

Accessories

Rail adapter

(for snapping the T03BU onto a top-hat rail)



Programming tool for T03BU

The programming tool contains a multilingual configuration software and PC-Interface USB / SP-translator

Head Transmitter / Transmitter RT420



- For head or rail mounting
- 2-, 3- and 4- wire
- Error signaling in case of sensor break or short-circuit

Characteristics

The RT420 is a installation resistance thermometer with transmitter. Pt100 temperature probes can be connected (2-, 3- or 4- wire technology). The device has a linearized 4..20 mA current output. The RT420 is fully potted, robust, shakeproof and durable. This makes it particularly suitable for stressing industrial application as well as outdoor usage.

The transmitter is factory preset, but can also be configured by the customer via programming tool. This makes customers' warehousing easier and has the advantages of a freely programmable measuring range.

The RT420 is suitable for head or rail mounting depending on design type. The device provides error signaling in case of sensor break or sensor short-circuit.

Technical data

| | |
|--------------------------|--|
| Measuring input | : Pt100 |
| Measuring range | : -200..+850 °C, programmable |
| Measuring span | : 25 to 1050 K |
| Lower range limit | : -200..+825 °C |
| Sensor connection | : 2-, 3- or 4- wire connection |
| Measuring rate | : < 700 ms |
| Output signal | : 4..20 mA, 2-wire technology |
| Accuracy | : ±0.25 °C or ±0.1 % of meas. span (higher value applicable) |
| Accuracy (output) | : < ±0.1 % of current signal |
| Power supply U_B | : 8..35 V DC |
| Permissible burden R_A | : $R_A \leq (U_B - 8 V) / 0.023 A$ (R_A in Ohm) |
| Power-on time | : 10 s |
| Working temperature | : -40..+85 °C |
| Electrical connection | : via screw terminals |
| Protection class | : housing: IP40
terminals: IP10 |

Design types

| | RT420 | RT420 - SG |
|--------------------|--|---|
| Housing / mounting | Head transmitter, suitable for head mounting | Head transmitter in snap-on housing, suitable for rail mounting |

Dimensions

| | RT420 | RT420 - SG |
|---------|-----------------|--------------------|
| Housing | Ø 44 mm x 19 mm | 22.5 x 78 x 105 mm |

Connection diagram



Ordering code

RT420 - / WE - - -

| | |
|-------------------------------|--|
| 1. Design type | |
| 00 | head transmitter |
| SG | head transmitter in snap-on housing |
| 2. Sensor connection | |
| P2 | Resistance thermometer Pt100, 2-wire |
| P3 | Resistance thermometer Pt100, 3-wire |
| P4 | Resistance thermometer Pt100, 4-wire |
| 3. Measuring range | |
| MBx | state desired measuring range
e.g.: MB -50..+400 °C
(max. possible measuring range: -200..+850 °C) |
| 4. Sensor break signal | |
| FBU | 3.5 mA |
| FBO | > 23 mA |

Accessories

Rail adapter

(for snapping the RT420-00 onto a top-hat rail)



Programming tool for RT420

The programming tool contains a multilingual configuration software, Programmer, USB connection cable. Configuring without computers is possible.

Universal Head Transmitter GITT01



- Freely programmable for resistance thermometers, thermocouples, resistance sensors, voltage sensors
- Electrically isolated

Characteristics

The GITT01 is a universally programmable transmitter for measuring temperature, resistance and voltage. The input signal is linearized and output as 4..20 mA or 20..4 mA signal. This allows to transmit signals over large distances. The GITT01 is well-suited for industrial application.

The transmitter is factory preset, but can also be configured by the customer via programming tool. This makes customers' warehousing easier and has the advantages of a freely programmable measuring range.

The GITT01 provides error signaling in case of sensor break or sensor short-circuit. PC-configuration is possible while the transmitter is in measuring mode.

Technical data

Measuring input : resistance thermometer, thermocouple, resistance, voltage

Input signal max. meas. range min. meas. range

Resistance thermometers

| | | |
|--------|-------------------|------|
| Pt100 | : -200..+850 °C | 10 K |
| Pt500 | : -200..+250 °C | 10 K |
| Pt1000 | : -200..+250 °C | 10 K |
| Ni100 | : -60 ... +250 °C | 10 K |
| Ni500 | : -60..+150 °C | 10 K |
| Ni1000 | : -60..+150 °C | 10 K |

Thermocouples

| | | |
|-----------------------|-------------------|-------|
| Type B (PtRh30-PtRh6) | : 0..+1820 °C | 500 K |
| Type C (W5Re-W26Re) | : 0..+2320 °C | 500 K |
| Type D (W3Re-W25Re) | : 0..+2495 °C | 500 K |
| Type E (NiCr-CuNi) | : -270..+1000 °C | 50 K |
| Type J (Fe-CuNi) | : -210..+1200 °C | 50 K |
| Type K (NiCr-Ni) | : -270..+1372 °C | 50 K |
| Type L (Fe-CuNi) | : -200.. + 900 °C | 50 K |
| Type N (NiCrSi-NiSi) | : -270..+1300 °C | 50 K |
| Type R (Pt13Rh-Pt) | : -50..+1768 °C | 500 K |
| Type S (Pt10Rh-Pt) | : -50..+1768 °C | 500 K |
| Type T (Cu-CuNi) | : -270..+ 400 °C | 50 K |
| Type U (Cu-CuNi) | : -200.. + 600 °C | 50 K |

Resistance-type sensor

| | | |
|------------|----------------|--------|
| Resistance | : 10.. 400 Ohm | 10 Ohm |
| Resistance | : 10..2000 Ohm | 10 Ohm |

Voltage sensor

| | | |
|---------|---------------|------|
| Voltage | : -10..100 mV | 5 mV |
|---------|---------------|------|

Sensor connection

| | |
|---------------------|-------------------------------|
| Resist. thermometer | : 2-, 3- or 4-wire connection |
| Thermocouple | : 2-wire connection |

| | |
|---------------------|---|
| Working temperature | : -40..+85 °C |
| Output signal | : 4..20 mA, 20..4 mA, 2-wire |
| Power supply U_B | : 8..35 V DC |
| Response time | : 1 s |
| Electric connection | : via screw terminals, max. cable cross-section 1.75 mm ² |
| Housing | : round head transmitter, Ø 44 x 21 mm, suitable for installation in connection head acc. to DIN 43729 form B |
| Protection class | : housing: IP54 terminals: IP00 |

Dimensions

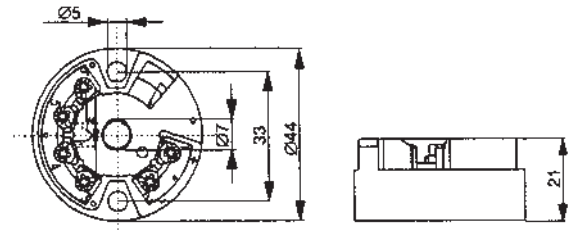

Connection diagram

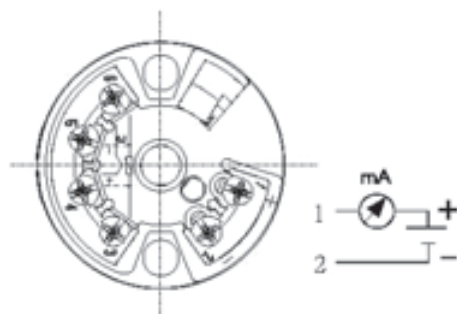
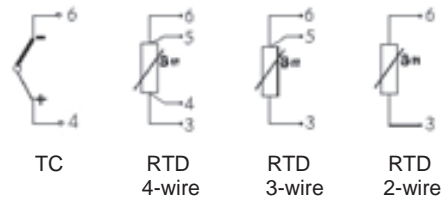

continued on next page

Ordering code

GITT01 - 1. - 2. - 3. - 4. - 5.

| 1. Input signal | |
|------------------------|--|
| 1 | resistance thermometer Pt100 |
| 2 | resistance thermometer Pt500 |
| 3 | resistance thermometer Pt1000 |
| 4 | resistance thermometer Ni100 |
| 5 | resistance thermometer Ni500 |
| 6 | resistance thermometer Ni1000 |
| B | type B (PtRh30-PtRh6) |
| C | type C (W5Re-W26Re) |
| D | type D (W3Re-W25Re) |
| E | type E (NiCr-CuNi) |
| J | type J (Fe-CuNi) |
| K | type K (NiCr-Ni) |
| L | type L (Fe-CuNi) |
| N | type N (NiCrSi-NiSi) |
| R | type R (Pt13Rh-Pt) |
| S | type S (Pt10Rh-Pt) |
| T | type T (Cu-CuNi) |
| U | type U (Cu-CuNi) |
| 7 | resistance 10..400 Ohm |
| 8 | resistance 10..2000 Ohm |
| 9 | voltage -10..100 mV |
| 2. Measuring range | |
| MBx | state desired measuring range
e.g.: MB -50..+400 °C
(must be within max. possible measuring range) |
| 3. Sensor break signal | |
| FBU | 3.6 mA |
| FBO | ≥ 21.0 mA |
| 4. Output signal | |
| A1 | 4..20 mA |
| A2 | 20..4 mA |
| 5. Options | |
| 00 | without option |
| Ex | with Ex protection (ATEX) for use in potentially explosive areas |

Accessories

Rail adapter

(for snapping the GITT01 onto a top-hat rail)



Programming tool for GITT01

The programming tool contains a multilingual configuration software and USB-connection cable

Transmitter GTMU-A5



- Transmitter for already existing Pt100 or NiCr-Ni sensors
- Ready for assembly

Characteristics

The GTMU A5 is a transmitter for external thermocouples (NiCr-Ni) or resistance temperature sensors (Pt100, 2- or 3- wire). The transmitter outputs linear current or voltage signals.

The GTMU A5 is particularly suitable if the temperature probe is already available or if housing and temperature sensor have to be apart from each other (e.g. due to high ambient temperatures).

The transmitter is adjusted according to customer requirements.

Technical data

| | |
|---------------------------------------|--|
| Possible sensor | : Pt100 (2- or 3- wire)
NiCr-Ni |
| Standard measuring range | |
| Pt100 | : 0..100 °C, 0..200 °C, -50..+50 °C,
-50..+150 °C |
| NiCr-Ni | : 0..100 °C, -50..+150 °C,
-200..+300 °C, 0..600 °C,
0..1150 °C
other ranges upon request |
| Max. possible measuring ranges | |
| Pt100 | : -200..+800 °C |
| NiCr-Ni | : -200..+1150 °C |
| Sensor connection | : insertion of sensor cable via PG7
connection to board via screw terminals |
| Output signal | : standard 4..20 mA (2-wire)
optional 0..1 V, 0..2 V, 0.5 V,
0..10 V (3- or 4-wire) |
| Power supply U_v | : 12..30 V DC (at 0..10 V: 18..30 V DC) |
| Permissible burden R_A | : (at 4..20 mA) $R_A = (U_v - 12 V) / 0,02 A$ |
| Permissible load R_L | : (at ... V) $R_L > 3000 \Omega$ |
| Working temperature | : 0..70 °C
(-40..+85 °C at Option RT420 / GITT) |
| Housing material | : ABS |
| Protection class | : IP65 |
| Mounting | : with fastening holes for wall mounting |
| Electrical connection | : elbow-type plug (EN 175301-803/A) |

Dimensions

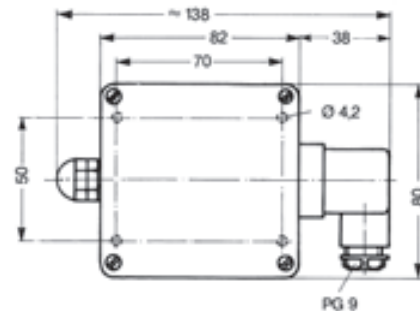

Connection diagram

2-wire (4..20 mA)

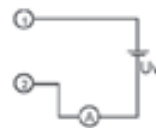

- 1 = supply voltage + U_v
- 2 = GND / signal

3-wire (.. V DC)

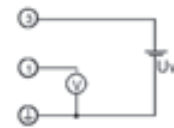

- 1 = signal +
- 3 = supply voltage + U_v
- ↓ = supply voltage - U_v
signal -

4-wire (.. V DC)



- 1 = signal +
- 2 = signal -
- 3 = supply voltage + U_v
- ↓ = supply voltage - U_v

continued on next page

Ordering code

GTMU-A5 - - - -

1. 2. 3. 4.

| | |
|--|---|
| 1. Sensor element | |
| P2 | resistance thermometer Pt100, 2-wire |
| P3 | resistance thermometer Pt100, 3-wire |
| K2 | thermocouple NiCr-Ni |
| 2. Measuring range (MB) | |
| MB1 | 0..100 °C <i>Pt100 / NiCr-Ni</i> |
| MB2 | -50..+150 °C <i>Pt100 / NiCr-Ni</i> |
| MB3 | 0..200 °C <i>only Pt100</i> |
| MB4 | -50..+50 °C <i>only Pt100</i> |
| MB5 | -200..+300 °C <i>only NiCr-Ni</i> |
| MB6 | 0..600 °C <i>only NiCr-Ni</i> |
| MB7 | 0..1150 °C <i>only NiCr-Ni</i> |
| MBx | desired measuring range (e.g. -50..+400 °C)
max. possible measuring range:
Pt100: -200..+800 °C / NiCr-Ni: -200..+1150 °C |
| 3. Output signal | |
| A1 | 4..20 mA (2-wire) (standard) |
| V1 | 0..1 V (3-wire) |
| V3 | 0..2 V (3-wire) |
| V4 | 0..5 V (3-wire) |
| V2 | 0..10 V (3-wire) |
| 4. Options (combination of multiple options upon request) | |
| 00 | without Option |
| VO | on-site display (display and control panel) |
| LACK | board varnished on both sides (for outdoor usage) |
| GITT | transmitter with electrical isolation
(only output 4..20 mA possible) |
| RT420 | transmitter particular for outdoor usage
(only with sensor element Pt100 and output 4..20 mA possible) |

Temperature Transmitter MU500L



Dimensions

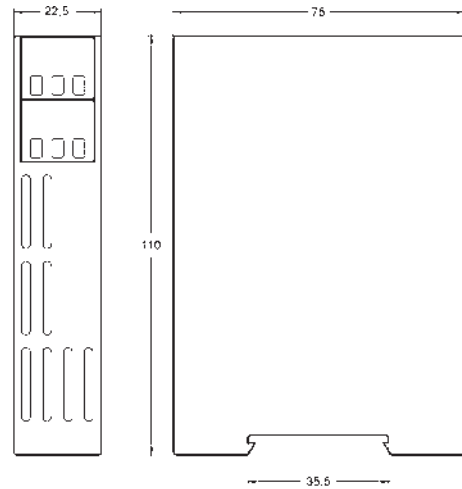

Characteristics

Temperature transmitter MU500L accept field signals of Pt100 or Pt1000 RTD sensors to the input which is filtered, isolated and converted into industry standard signals for process control systems. Special circuit design makes it possible, to produce any useful measurement ranges.

Technical data

Power supply

Supply voltage : 230 V AC $\pm 10\%$; 24 V DC $\pm 20\%$
 Frequency AC : 47..63 Hz
 Power consumption : <1.5 VA
 Operating temperature : -10..+60 °C
 CE- conformity : EN 61326-1:2013, EN 60664-1:2007
 Explosion protection : Approval: TÜV 03 ATEX 2283
 Marking : II (1) G [Ex ia] IIC bzw. II (1) D [Ex iaD]

Measuring input *

Start value Pt100 : in the range -100 °C.. +100 °C
 Span Pt100 : in the range 50..600 °C
 Start value Pt1000 : in the range -50 °C..+50 °C
 Span Pt1000 : in the range 10..200 °C
 Sensor current : ca. 0.6 mA (no self heating)
 Line resistance : max. 10 Ω , automatic compensation at 3-wire connection

Start value adjustment

4mA/2V adjustment : approx. ± 10 °C

Span

4mA/2V adjustment : approx. ± 1 mA or ± 0.5 V

Broken line

short circuit : output shows max. value

Outputs

Current : 0/4..20 mA, max. 500 Ω

Voltage : 0/2..10 V, max. 10 mA, simultaneously to the current output max. 1 mA

Accuracy

Temperature error : $\leq 0.2\%$

Case

Temperature error : $\leq 0.01\%/K$

Weight

Case : Polycarbonate, UL94V-0
 T35 acc. to DIN EN 60715

Connection

Weight : approx. 140g

Protection class

Connection : screw terminals with pressure plate, max. 2.5 mm²

Protection class : case IP30, terminals IP20, BGVA3

*Minimal and maximal range for start value and span of the measuring range.

Connection diagram

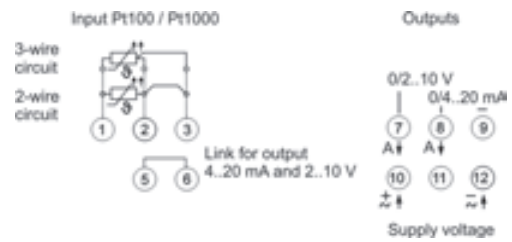

Ordering code

MU500L - 1. - 2. - 3.

| | |
|---------------------------|---|
| 1. Device type | 51 Pt100 |
| | 53 Pt1000 |
| 2. Supply voltage | 0 230 V AC $\pm 10\%$ |
| | 5 24 V DC $\pm 15\%$ |
| 3. Measuring range | Please state in clear text
e. g.: -50..+100 °C |

Universal Transmitter MU500



Dimensions

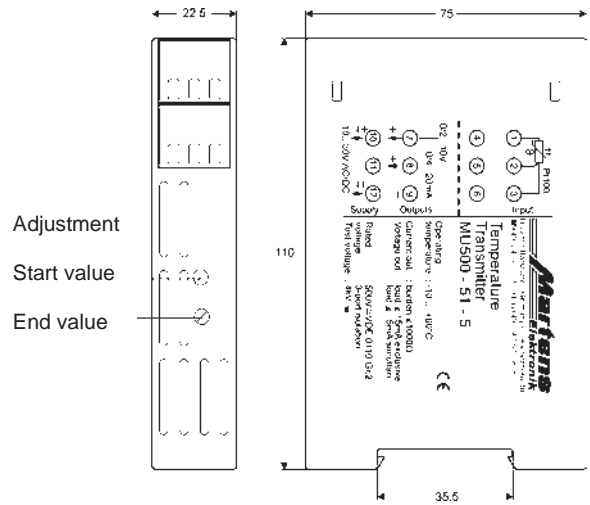

Characteristics

Temperature transmitter MU500 accept field signals of Pt100 or Pt1000 RTD sensors to the input which is filtered, isolated and converted into industry standard signals for process control systems. The multipurpose design of inputs and outputs, also the wide range of the supply voltage reduces the number of types. The small case allows space-saving mounting.

Technical data

Power supply
Supply voltage : 85..265 V AC/110..125 V DC or 10..30 V AC/10..42 V DC
Frequency AC : 40..400 Hz
Power consumption : max. 2.2 W , max. 3.3 VA
Operating temperature : -10..+60 °C
CE-conformity : EN 61326-1:2013; EN 60664-1:2007

Input
RTD Pt100 : 13 ranges, switch selectable
- Sensor current : Pt100 approx. 1 mA
RTD Pt1000 : 16 ranges, switch selectable
- Sensor current : Pt1000 approx. 0.25 mA
Line resistance : max. 100 Ω
Accuracy : ≤ 0.2 %
Zero adjust : Pt100 approx. ± 8 Ω (± 20 °C)
Pt1000 approx. ± 8 Ω (± 2 °C)
End value : adjustable approx. +/-20 %
Sensor error;
- broken or shorted line: output rises to max. output value

Outputs
Current : 0/4..20 mA switch selectable
burden ≤ 1 kΩ
Voltage : 0/2..10 V switch selectable
load max. 15 mA , short-circuit-proof
(simultaneously to the current output
max. 5 mA)

Case : Polycarbonate, UL94V-0
TS 35 acc. to DIN EN 60715:2001-09
Weight : approx. 200 g
Protection class : case IP30, terminals IP20, BGV A3
Electrical connection : screw terminals with pressure plate,
max. 2.5 mm²

Connection diagram

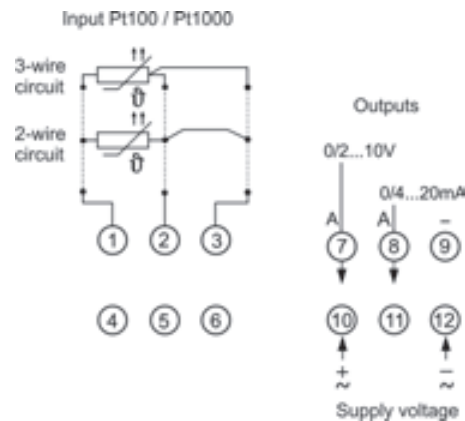

Ordering code

1. 2.
MU500 - -

| 1. Device type | |
|-------------------|-----------------------------|
| 51 | Pt100, 13 measuring ranges |
| 53 | Pt1000, 16 measuring ranges |
| 2. Supply voltage | |
| 0 | 85..265 V AC |
| 5 | 10..30 V AC/DC |

Universal Transmitter MU500Ex



Outputs

| | |
|------------------|--|
| Current | : 0/4..20 mA DC switch selectable, burden $\leq 1 \text{ k}\Omega$ |
| Voltage | : 0/2..10 V DC switch selectable, load max. 15 mA, short-circuit-proof (simultaneously with current output 5 mA) |
| Rated voltage | : 253 V AC or 125 V DC (U_m) acc. to EN 60079-0 |
| Accuracy | : $\leq 0.2 \%$ |
| Case | : Polycarbonate UL94V-0 TS 35 |
| Weight | : approx. 200 g |
| Protection class | : case IP30, terminals IP20 (BGV A3) |
| Connection | : screw terminals with pressure plate max. 2.5 mm ² |
| Mounting | : installation in dry, clean and well monitored areas |

Characteristics

Temperature transmitters series MU500-Ex offer an intrinsically safe input and convert RTD sensor signals (Pt100 or Pt1000) into industry standard signals. The device includes a full 3-port isolation.

Technical data

Power supply

| | |
|--------------------------|--|
| Supply voltage | : 85..253 V AC/110..125 V DC
10..30 V AC/DC |
| Frequency AC | : 40..400 Hz |
| Power consumption | : < 3.3 VA |
| Operating temperature | : -10..+60 °C |
| CE-conformity | : ATEX-Richtlinie 2014/34/EU |
| Standards | : EN 60079-0:2006, EN 60079-11:2007
EN 61241-0:2006, EN 61241-11:2006 |
| EMC-directive / standard | : 2014/30/EU / EN 61326-1:2013 |

Explosion protection

| | |
|------------------|--|
| Approval | : TÜV 03 ATEX 2283, |
| Marking | : II (1) G [Ex ia Ga] IIC or
II (1) D [Ex ia Da] IIIC |
| | U_0 I_0 P_0 C_0 L_0 |
| MU500Ex- ... -51 | : 1.3 V <3mA <3mW 29 μ F 100mH |
| MU500Ex- ... -53 | : 4.9 V <3mA <3mW 2.2 μ F 100mH |
| Ci, Li | : 5 nF, ca. 0 mH |

The intrinsically safe circuit is galvanically separated from the non-intrinsically safe circuits up to a peak crest value of the voltage of 375 V.

Measuring input

| | |
|-----------------|--|
| Sensor current | : Pt100 approx 1 mA,
Pt1000 approx. 0.25 mA |
| Line resistance | : max. 100 Ω , automatic compensation with 3-wire connection |
| Zero adjust | : Pt100 approx. $\pm 8 \Omega$ ($\triangleq 20 \text{ }^\circ\text{C}$)
Pt1000 approx. $\pm 8 \Omega$ ($\triangleq 2 \text{ }^\circ\text{C}$) |
| End value | : approx. +/-20 % adjustable |
| Sensor error | : output rises to max. output (voltage output >12V DC current output > 25 mA) |

Dimensions

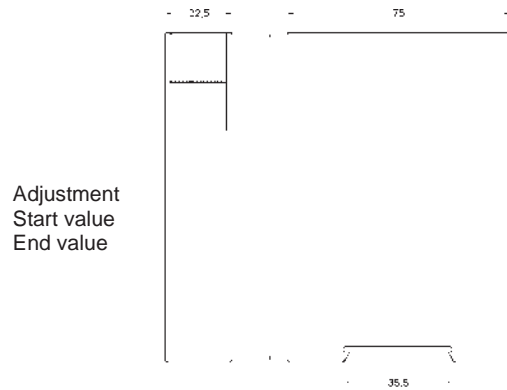

Connection diagram

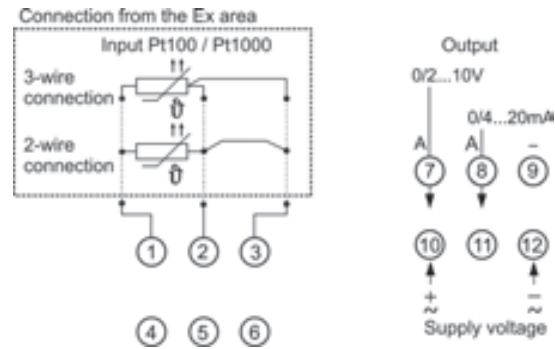

Ordering code

MU500Ex - - -

| 1. Device type | |
|-------------------|-----------------------------|
| 51 | Pt100, 13 measuring ranges |
| 53 | Pt1000, 16 measuring ranges |
| 2. Supply voltage | |
| 0 | 85..253 V AC/110..125 V DC |
| 5 | 10..30 V AC/DC |
| 3. Options | |
| 00 | without option |

Thermocouple Transmitter TC500



Dimensions

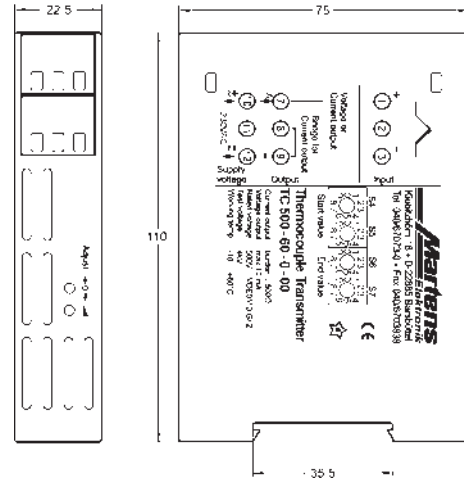

Characteristics

Thermocouple Transmitter TC500 converts thermovoltages into standard industry signals 0/4..20 mA or 0/2..10 V DC. The measuring range is programmable via rotary switches at the side.

Technical data

- Power supply**
 Supply voltage : 230 V AC $\pm 10\%$ or 24 V DC $\pm 15\%$
 Frequency AC : 47..63 Hz
 Power consumption : < 3.5 VA
 Operating temperature : -10..+60 °C
 CE-conformity : EN 61326-1:2013
 EN 60664-1:2007
- Input**
 Thermocouple
 Type J : Fe-CuNi, in range -100..+800 °C
 Type K : NiCr-Ni, in range -150..+1200 °C
 Type S : Pt10Rh-Pt, in range 0..+1600 °C
- Output**
 Current : 0..20 mA, 4..20 mA switch selectable, burden $\leq 500 \Omega$
 Voltage : 0..10 V, 2..10 V switch selectable, load max. 10 mA, short-circuit-proof
- Start value : adjustable approx. $\pm 5\%$
 End value : adjustable approx. $\pm 5\%$
 Broken line : outputs takes the end value + 1 %, overflow indication
- Short-circuit : no indication (output takes terminal temperature)
- Accuracy : $\leq 0.15\%$, 1 °C
 Temperature coefficient : $\leq 0.01\%/K$
- Case** : Polycarbonate, UL94 V-0
 TS35 acc. to DIN EN 60715:2001-09
- Weight : approx. 200 g
 Connection : screw terminals with pressure plate max. 2.5 mm²
 Protection class : case IP30
 terminals IP20 acc. to BGV A3

Connection diagram

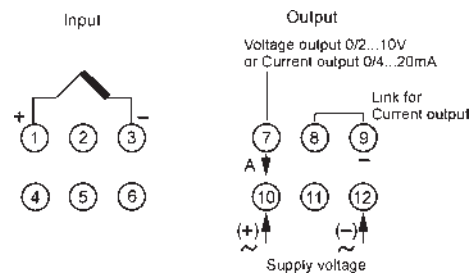

Ordering code

TC500 - - -

1. 2. 3.

| | | |
|--------------------------|----|--|
| 1. Input | 60 | Thermocouple J, K, S programmable, output 0/4..20 mA or 0/2..10 V DC |
| 2. Supply voltage | 0 | 230 V AC $\pm 10\%$ |
| | 5 | 24V DC $\pm 15\%$ |
| 3. Options | 00 | without option |

Temperature Transmitter PMT50-2 /-3



- Signal conditioning – linearisation – output characteristic transformation
- Input for resistance and Potentiometer or RTD Pt100/Pt1000 and thermocouples
- Measuring range programmable
- Linearisation or transformation of output characteristic via 32 base-points programmable
- Automatic fault detection in the measuring circuit

Characteristics

The programmable universal transmitter PMT50 operates with analog input signals. The device convert input signals to analog output 0/4..20 mA; 0/2..10 V DC. Optional a serial interface is available. The device offers a linearisation function for any sensor curves and a simulator function. The integrated transmitter supply 24 V DC max. 30 mA allows the feeding of 2-and 3-wire sensors. 4 alarm outputs for monitoring and controlling are available.

Technical data

Power supply

Supply voltage : 230 V AC $\pm 10\%$
 : 115 V AC $\pm 10\%$
 : 24 V DC $\pm 15\%$

Power consumption : < 5 VA

Operating temperature : -10..+55 °C

CE – conformity : EN 61326-1:2013, EN 60664-1:2007

Inputs

Fault detection : type -2: (only resistance measurement) broken line;
 type -3: broken line (Pt100 / Pt1000,TC) and short circuit (only Pt100 / Pt1000)

Device type 2

Input : resistance 0..100 k Ω ,
 potentiometer min.1 k Ω .. max. 100 k Ω
 Accuracy : < 0.2 %, ± 1 Digit

Device type 3

Input : Pt100 (3-wire) -100.0..+600.0 °C
 Pt1000 (3-wire) -100.0..+300.0 °C
 : Thermocouple (TC)
 type J -100.0..+800.0 °C
 type K -150..+1200 °C
 type N -150..+1200 °C
 type S -50..+1600 °C
 Accuracy : < 0.1 %, ± 1 Digit

Outputs

Alarm outputs : relay SPDT
 < 250 V AC < 250 VA < 2 A
 cos Phi ≥ 0.3
 < 300 V DC < 40 W < 2 A

Analog output : 0/4..20 mA burden $\leq 500 \Omega$,
 0/2..10 V burden > 500 Ω isolated
 output changes automatically (burden depending)

Fault indication : for broken line or short circuit detection
 → analog output (programmable)
 0 mA, < 3.6 mA or >21.5 mA
 → Alarm relays
 min. or max. programmable

Bus system

Modbus : RS485, RTU or ASCII
 max. 38400 Baud

Profibus : Profibus DP

Connection : 9 pole D-SUB plug in the front

Display : Graphic-LCD-Display

128 x 64 Pixel,

with white LCD backlight

Case : Polyamide (PA) 6.6 , UL94V-0

TS35 acc. to DIN EN 60715

Weight : approx. 450 g

Connection : screw terminals 0.14..2.5 mm²

AWG 26..AWG14

Protection class : case IP30, terminals IP20 acc. to

BGV A3

Dimensions

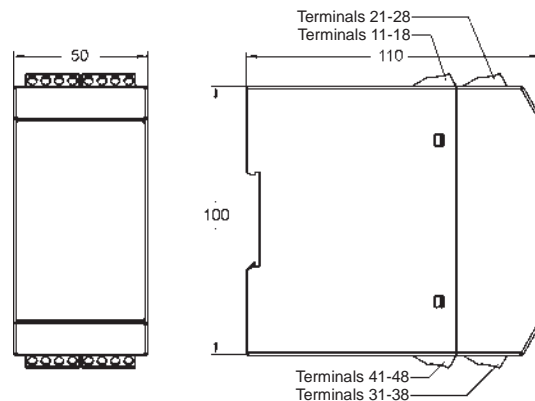

continue next page

Connection diagrams

Device type PMT50-2
Resistance, Potentiometer

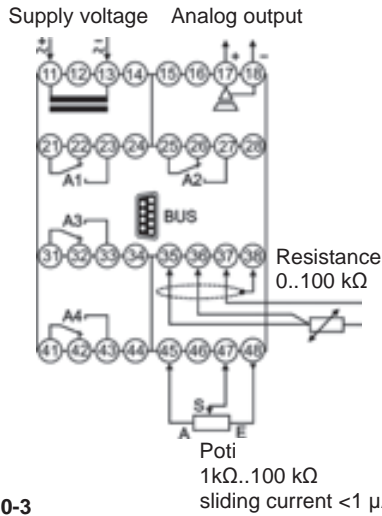

Device type PMT50-3
Pt100, Pt1000, thermocouple

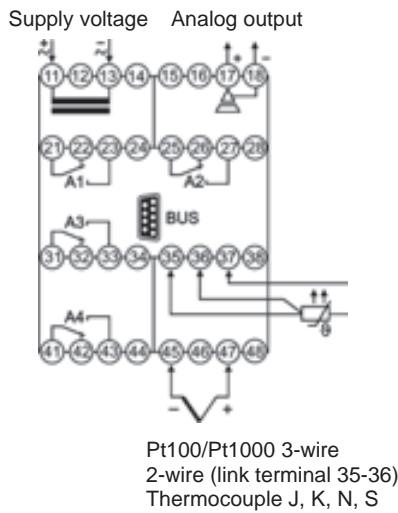

Ordering code

1. 2. 3. 4. 5. 6.
PMT50 - - - - - -

| | |
|--|---|
| 1. Device type/input | |
| 2 | Resistance in the range 0..100 kΩ
Poti 1 kΩ..100 kΩ |
| 3 | RTD Pt100, 3-wire, -100.0..+600.0 °C
RTD Pt1000, 3-wire, -100.0..+300.0 °C
Thermocouple
J (Fe-CuNi), -100.0..+800.0 °C
K (NiCr-Ni), -150..+1200 °C
N (NiCrSi-NiSi), -150..+1200 °C
S (Pt10Rh-Pt), -50..+1600 °C |
| 2. Analog output | |
| AO | 0/4..20 mA, 0/2..10 V DC
isolated |
| 3. Alarm outputs | |
| 00 | not installed |
| 2R | 2 relay outputs, A1, A2 SPDT |
| 4. Alarm output/BUS configuration | |
| 00 | not installed |
| 2R | 2 relay outputs, A3, A4 SPDT |
| MB | Modbus RTU/ASCII, RS485 |
| PB | Profibus DP |
| 5. Supply voltage | |
| 0 | 230 V AC, ± 10 % 50-60 Hz |
| 1 | 115 V AC, ± 10 % 50-60 Hz |
| 5 | 24 V DC, ± 15 % |
| 6. Options | |
| 00 | without option |

Bus connection

| Modbus | | |
|----------|---------------------|------------------|
| PIN | Signal | EIA/TIA-485 Name |
| 5 | D1 | B / B' |
| 9 | D0 | A / A' |
| 1 | Common | C / C' |
| Profibus | | |
| 3 | RxD / TxD-P | |
| 5 | DGND | |
| 6 | VP / +5V max. 10 mA | |
| 8 | RxD / TxD-N | |

9-pol. D-Sub plug
in the front

Temperature Transmitter PMT50Ex-2 /-3



- Signal conditioning – linearisation – output characteristic transformation
- Input for resistance and Potentiometer or RTD Pt100/Pt1000 and thermocouples
- Measuring range programmable
- Linearisation or transformation of output characteristic via 32 base-points programmable
- Automatic input fault detection

Characteristics

The programmable Temperature Transmitter PMT50 operates with RTD and thermocouple input signals. The device convert the signal to analog output 0/4..20 mA; 0/2..10 V DC. Optional a serial interface is available. The device offers a linearisation function for any sensor curves and a simulator function. The integrated transmitter supply 24 V DC max. 30 mA allows the feeding of 2-and 3-wire sensors. 4 alarm outputs for monitoring and controlling are available.

Technical data

Power supply

Supply voltage : 230 V AC ±10 %
 115 V AC ±10 %
 24 V DC ±15 %
 Um = 253 V AC or 125 V DC (terminals 11 and 13)

Power consumption : < 5 VA
 Operating temperature : -10..+55 °C
 CE-conformity : ATEX-directive 2014/34/EU
 Standards : EN 60079-0:2006 EN60079-11:2007
 EN 61241-0:2006 EN61241-11:2006
 EMC-directive / standard : 2014/30/EU / EN 61326-1:2013

Explosion protection

Marking : II (1) G [Ex ia] IIC/IIB bzw. II (1) D [Ex iaD]
 Approval : TÜV 08 ATEX 554329

Device type 2

Input : resistance 0..20 kΩ (terminals 35, 36, 37, 38)

Fault detection : broken line

Accuracy : < 0.2 %, ±1 Digit

Max. U_o no load : 1.4 V

Max. I_o short circuit : 2,5 mA

Max. output power P_o : 3 mW

Resistance : 5600 Ω

Characteristic curve : trapezoidal

Internal inductivity : 4 µH

Internal capacity : 135 nF

Explosion protection Ex ia/IIC ia/IIB

Max. external inductivity : 100 mH 100 mH

Max. external capacity : 25 µF 120 µF

Input : Potentiometer min. 1 kΩ..max. 100 kΩ (terminals 45, 47, 48)

Accuracy : <0.2 %, ±1 Digit

Max. values U_o : 9.6 V

Max. I_o : 56 mA

Max. P_o : 200 mW

Resistance R : 259 Ω

Characteristic curve : trapezoidal

Internal inductivity : 4 µH

Internal capacity : negligible

Explosion protection Ex ia/IIC ia/IIB

Max. external inductivity : 5 mH 20 mH

Max. external capacity : 0.48 µF 2 µF

Device type 3

Input : Pt100 (3-wire) -100.0..+600.0 °C
 Pt1000 (3-wire) -100.0..+300.0 °C
 thermocouple (TC)
 type J -100.0..+800.0 °C
 type K -150..+1200 °C
 type N -150..+1200 °C
 type S -50..+1600 °C (terminals 35, 36, 37; 45, 47)

Fault detection : broken line (Pt100 / Pt1000,TC) or short circuit (only Pt100 / Pt1000)

Accuracy : < 0.1 %, ±1 Digit

Max. voltage no load U_o : 1,4 V

Max. short circuit curr. I_o : 2.5 mA

Max. output power P_o : 3 mW

Resistance R : 5600 Ω

Characteristic curve : trapezoidal

Internal inductivity : 4 µH

Internal capacity : 135 nF

Explosion protection Ex ia/IIC ia/IIB

Max. external inductivity : 100 mH 100 mH

Max. external capacity : 25 µF 120 µF

Outputs

Alarm outputs : relay SPDT
 < 250 V AC < 250 VA < 2 A
 cos Phi ≥ 0.3
 < 300 V DC < 40 W <2 A (terminals 21, 22, 23; 25, 26, 27)

Analog output : 0/4..20 mA burden ≤ 500 Ω
 0/2..10 V burden > 500 Ω, isolated output changes automatically (burden depending)

- Accuracy : 0.2 %; TK 0.01 % / K (terminals 17, 18)

Fault function : for broken line or short circuit detection
 → analog output (programmable)
 0 mA, < 3.6 mA or >21.5 mA
 → alarm relays
 min. or max. programmable

Bus system

Modbus : RS485, RTU or ASCII
 max. 38400 Baud

Profibus : Profibus DP

Connection : 9 pole D-SUB plug in the front

Display : graphic-LCD-display, 128 x 64 Pixel with white LCD backlight

Product information Flow - Temperature

Case : Polyamide (PA) 6.6, UL94V-0
TS35 acc. to DIN EN 60715
Weight : approx. 450 g
Connection : screw terminals 0.14..2.5 mm²
AWG 26..AWG14
Protection class : case IP30, terminals IP20 acc. to
BGV A3

Dimensions

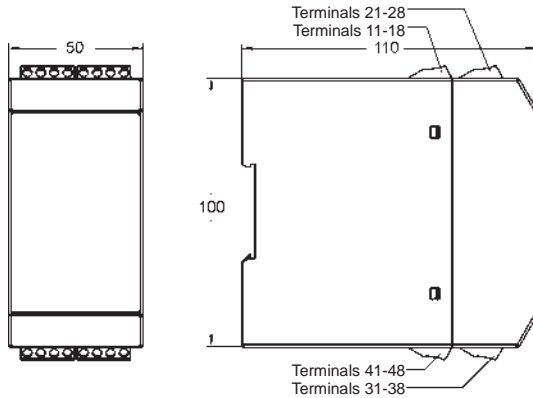

Bus connection

| Modbus | | |
|----------|---------------------|--------------------|
| PIN | Signal | EIA / TIA-485 Name |
| 5 | D1 | B / B' |
| 9 | D0 | A / A' |
| 1 | Common | C / C' |
| Profibus | | |
| 3 | RxD / TxD-P | |
| 5 | DGND | |
| 6 | VP / +5V max. 10 mA | |
| 8 | RxD / TxD-N | |

9 pol. D-Sub plug
in the front

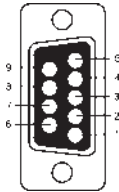

Connection diagram

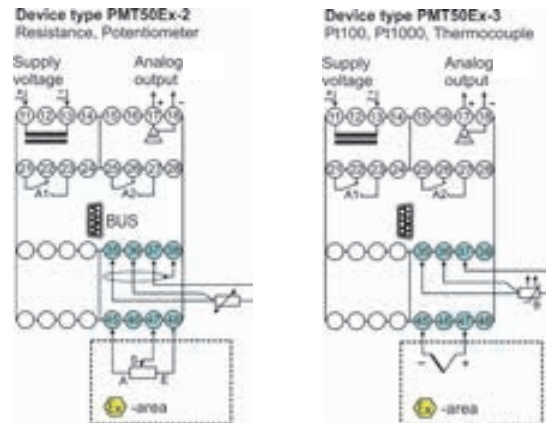

Ordering code

PMT50Ex - 1. - 2. - 3. - 4. - 5. - 6.

| | |
|-----------------------------|---|
| 1. Device type/input | |
| 2 | Resistance in the range 0..20 kΩ
Poti 1 kΩ..100 kΩ |
| 3 | RTD Pt100, 3-wire, -100.0..+600.0 °C
RTD Pt1000, 3-wire, -100.0..+300.0 °C
Thermocouple
J (Fe-CuNi), -100.0..+800.0 °C
K (NiCr-Ni), -150..+1200 °C
N (NiCrSi-NiSi), -150..+1200 °C
S (Pt10Rh-Pt), -50..+1600 °C |
| | Inputs intrinsically safe EX II (1) G [Ex ia] IIC/IIB
EX II (1) D [Ex iaD] |
| 2. Analog output | |
| AO | 0/4..20 mA, 0/2..10 V DC
isolated |
| 3. Alarm outputs | |
| 00 | not installed |
| 2R | 2 relay outputs, A1, A2 SPDT |
| 4. BUS configuration | |
| 00 | not installed |
| MB | Modbus RTU/ASCII, RS485 |
| PB | Profibus DP |
| 5. Supply voltage | |
| 0 | 230 V AC, ± 10 % 50-60 Hz |
| 1 | 115 V AC, ± 10 % 50-60 Hz |
| 5 | 24 V DC, ± 15 % |
| 6. Options | |
| 00 | without option |

ISO-TC

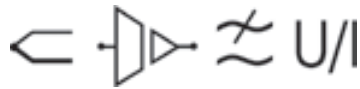

Characteristics

The **ISO-TC Module** offers signal conditioning of thermocouples (standard types J, K and T). Linearisation is done by the module. Maximum measurement range (type K) is -100°C to 1200°C. The standard module has a fixed range (-100°C to +100°C, or +200°C, +500°C, +1000°C, +1200°C) plus type to be specified with order. Calibration is done for this range. Optionally up to three switchable ranges are selectable. The CJC is integrated in the connector, cable break is indicated by an LED. Depending on the base configuration the module has voltage and current outputs.

Technical Data

| | |
|--|---|
| Supply voltage | 24 V DC ± 10 % |
| Power consumption at nominal voltage
(without sensor / without load) | 90 mA |
| Electrical isolation
(3-way isolation) | 1000 V DC |
| Accuracy¹ | 0.2 % |
| Cut-off frequency
(standard / maximum) | 10 Hz / 5 kHz |
| Linearity (typical) | 0.1 % |
| Input
Thermocouple
Input resistance | Type K, J, T ² , R ³
10 MΩ |
| Output – Voltage
Output range
(V1 / V2) | ± 10 V / 0..10 V |
| Output – Current
Output range
(A1 / A2 / A3) | ± 20 mA / 0..20 mA / 4..20 mA |
| Max. load current (U output) | ± 10 mA |
| Residual ripple @
f _g = 5 kHz | typ. 2 mV _{pp} |
| Cable break | red LED |
| Ranges
Maximum range
Standard ranges (selectable)
Minimum range
Ranges per module (standard)
Maximum numbers | -250°C..+1200°C
200, 500, 1000, 1200°C
-100°C..+100°C
1
4 |
| Environmental temperature | 0..50 °C |
| Plug-in filter
Standard frequencies in Hz | 10, 30, 50, 100, 300, 500,
1 k, 3 k, 5 k, 10 k |

Remarks to technical data:

- *1 Input connector must be attached for 30 minutes to module. A possible offset can be corrected with trimmer ZERO-A
- *2 Accuracy for type T is only met up to -230°C with negative range.
- *3 Accuracy for type R is only met with positive range, with negative range deviation is < 1%.

Block Diagram

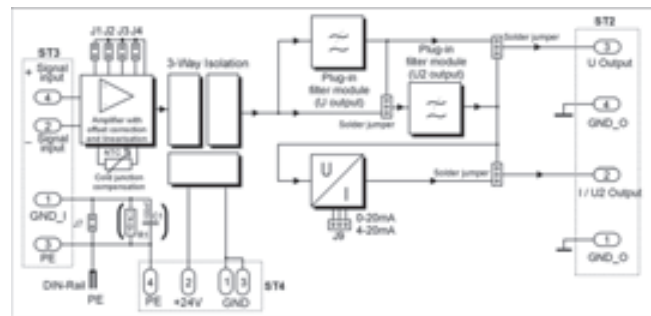

Dimensions

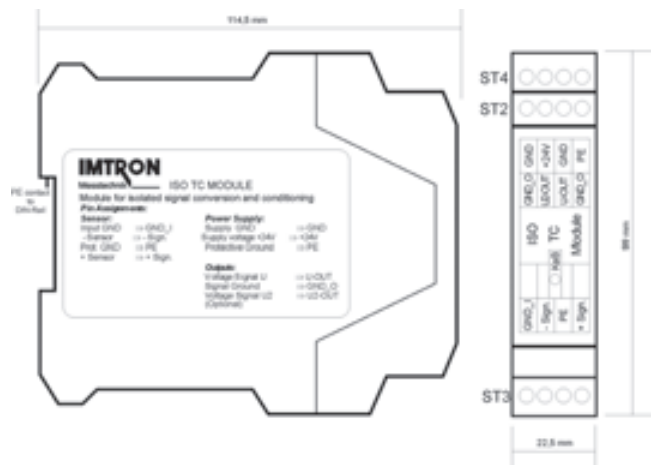

Ordering Code

- 60-ISO-TC-A-B-MBS-XX-YY-ZZ
- A = 1 (1 output), 2 (2 outputs)
 - B = Type J, K, T, R
 - MBS = Range 1, 2, 5, 10, 12 (+100, 200, 500, 1000, 1200 °C)
 - XX = Filter frequency
 - YY = Characteristics (BW = Butterworth, BS = Bessel)
 - ZZ = Voltage resp. current output

Example: 60-ISO-TC-1-K-10-10 Hz-BW-V1

ISO-Pt100

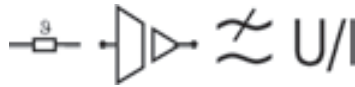

Characteristics

The **ISO-Pt100 Module** offers signal conditioning of Pt100 sensors in 4-wire technology. Linearisation is done by the module, with a fixed range of -100 to +100, +200, or +500°C, to be specified with order. Sensor supply of 1 mA constant is isolated, provided by the module. Depending on the base configuration the module has voltage and current outputs.

Technical Data

| | |
|--|--|
| Supply voltage | 24 V DC ± 10 % |
| Power consumption at nominal voltage
(without sensor / without load) | 65 mA |
| Electrical isolation
(3-way isolation) | 1000 V DC |
| Accuracy | 0.2 % |
| Cut-off frequency
(standard / maximum) | 5 Hz / 10 kHz |
| Linearity (typical) | 0.1 % |
| Input
Sensor
Input resistance | Pt100 RTD
10 MΩ |
| Output – Voltage
Output range
(V1 / V2) | ± 10 V / 0..10 V |
| Output – Current
Output range
(A1 / A2 / A3) | ± 20 mA / 0..20 mA / 4..20 mA |
| Max. load current (U output) | ± 12 mA |
| Residual ripple @
f _g = 5 kHz
f _g = 10 kHz | typ. 2 mV _{pp}
typ. 5 mV _{pp} |
| Sensor supply | Constant current 1 mA |
| Multi-wire technology | 4-wire |
| Range
1 fixed range to be specified with order | -100°C..+100°C
-100°C..+200°C
-100°C..+500°C |
| Environmental temperature | 0..50 °C |
| Plug-in filter
Standard frequencies in Hz | 10, 30, 50, 100, 300, 500,
1 k, 3 k, 5 k, 10 k |

Block Diagram

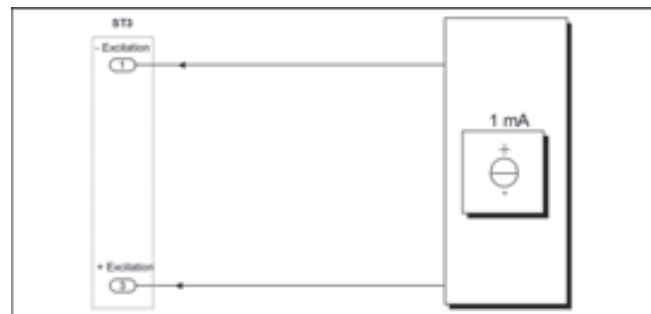
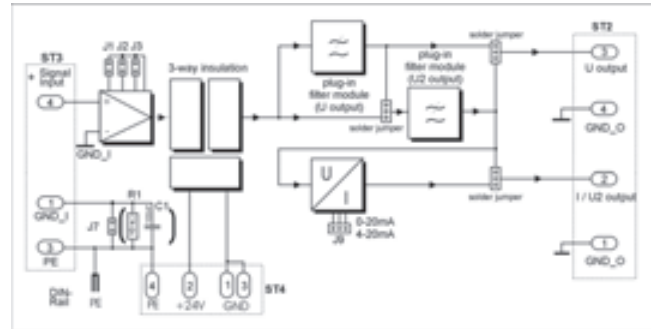

Dimensions

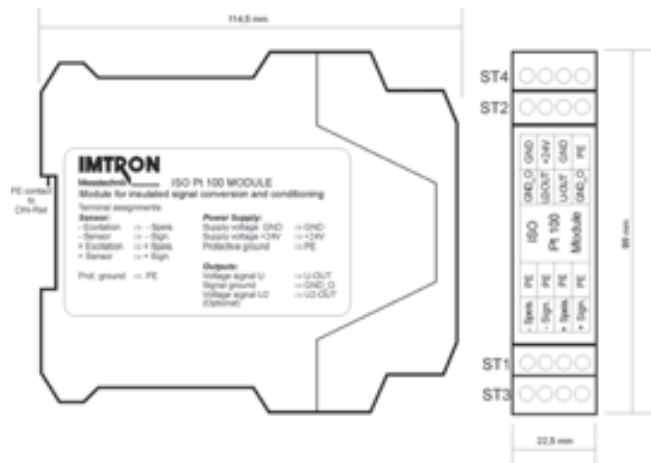

Ordering Code

60-ISO-PT100-A-MBS-XX-YY-ZZ

- A = 1 (1 output), 2 (2 outputs)
- MBS = Range select 1, 2, 5 (+100, 200, 500 °C)
- XX = Filter frequency
- YY = Characteristics (BW = Butterworth, BS = Bessel)
- ZZ = Voltage resp. current output

Example: 60-ISO-PT100-1-5-10 kHz-BW-V1

CAN Compact Modules

Characteristics

The SIQUAD **CAN Compact Modules** offer computer-controlled signal conditioning of various sensors. There are a universal or sensor-specific amplifiers available. It has 1 DSP per amplifier unit. Signal output is digital via CAN. Protocol is CAN 2.0B. Parameter setting is done with the software DaSoft via a USB-to-CAN interface. Signal filtering can be configured from 3..3000 Hz at 20 kS/s sample rate.



Technical Data

| | | |
|---------------------------|------------------|---|
| General | Accuracy | see sensors |
| | Channels/unit | 4, 2x4, isolated (8, 2x8, isolated inputs with common ground) |
| | AD converter | 24 bit / channel |
| | Sample rate | max. 20 kHz |
| | Band width | max. 5 kHz |
| | Digital output | CAN |
| | Input protection | ± 80 V, ESD IEC 1000-4-2 |
| | Supply voltage | 9..36 V DC |
| Environmental temperature | 0..+50 °C | |
| Thermo-couples J,K | Range | -100 to +100, +200, +500, +1000 (1200) °C |
| | Accuracy | ± 0.1 % (without CJC) |
| Pt100 | Range | -100 to +100, +200, +500, +1000 °C |
| | Accuracy | ± 0.1 % |

Block Diagram (exemplary for 2 channels)

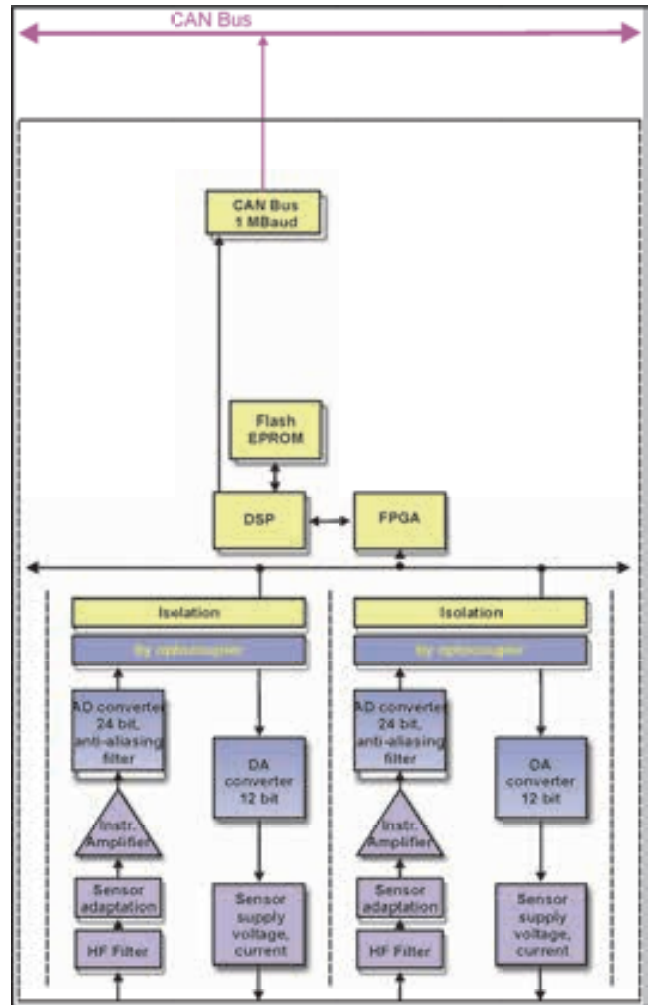

Dimensions

VCS: 130 x 250 x 45 mm, 130 x 130 x 45 mm (WxHxD)

VCD: 130 x 250 x 75 mm, 130 x 130 x 75 mm (WxHxD)

depending on type of amplifier

Ordering Code

56-VCS-C-XXX-Y-N-24V-Z with 1 amplifier card

56-VCD-C-XXX-Y-N-24V-Z with 2 amplifier cards

XXX = TC, Type J, K, a.A.; PT;

N = 1x4=4, 2x4=8, 1x8=8, 2x8=16 channels

Z = Box H, Flange L, DIN-rail T

Temperature Guard TG50



| | |
|------------------|--|
| Output | |
| Alarm A1-A4 | : relay SPDT
< 250 V AC < 250 VA < 2 A
cos Phi ≥ 0.3
< 300 V DC < 40 W < 2 A |
| Analog | : 0/4..20 mA burden ≤500 Ω
0/2..10 V burden >500 Ω
isolated, automatic output changing
(burden dependent) |
| - Accuracy | : 0.2 %;TK 0.01 %/K |
| Fault indication | : for broken line or short circuit detection
→ analog output (programmable)
0 mA, < 3.6 mA or >21.5 mA
→ Alarm relays
min. or max. function programmable |
| Case | : Polyamide (PA) 6.6 , UL94V-0
TS35 acc. to DIN EN 60715:2001-09 |
| Weight | : approx. 450 g |
| Connection | : screw terminals 0.14..2.5 mm ²
AWG 26..AWG14 |
| Protection class | : case IP30, terminals IP20 acc. to
BGV A3 |

Characteristics

The Temperature-Guard TG50 has inputs for temperature probes RTD (Pt100/Pt1000) and thermocouple J, K, N and S. Simple programming, up to 4 alarm outputs (SPDT) and an available fully isolated free programmable analog output 0/4..20 mA; 0/2..10 V DC offers a lot of solutions for temperature monitoring. Peak value indication for minimum and maximum measured temperature are stored in the background and can be read out from the display at any time.

Technical data

| | |
|-----------------------|---|
| Power supply | |
| Supply voltage | : 230 V AC ±10 %
115 V AC ±10 %
24 V DC ±15 %
: < 5 VA |
| Operating temperature | : -10..+55 °C |
| CE-conformity | : EN 61326-1:2013
EN 60664-1:2007 |
| Input | |
| Fault function | : break of wire (RTD Pt100/1000,
Thermocouple) and short-circuit
(only Pt100/1000) |
| RTD | : Pt100 (3-wire) -100.0..+600.0 °C
Pt1000 (3-wire) -100.0..+300.0 °C
: Thermocouple (TC)
type J -100.0..+800.0 °C
type K -150..+1200 °C
type N -150..+1200 °C
type S -50..+1600 °C
cold junction compensation integrated |
| Accuracy | : <0.1 %, ±1 Digit |
| Display | : Graphic LCD-Display, 128 x 64 Pixel,
with white back-lite |

Dimensions

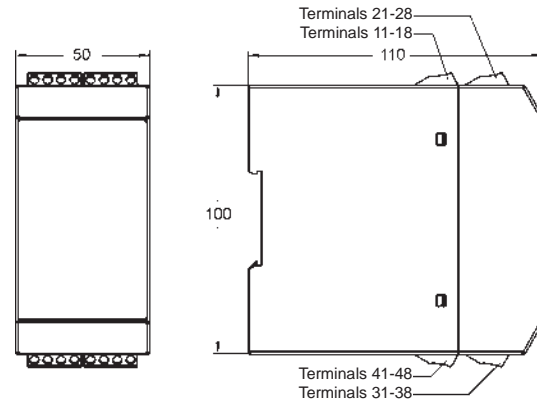

Continue next page.

Connection diagram

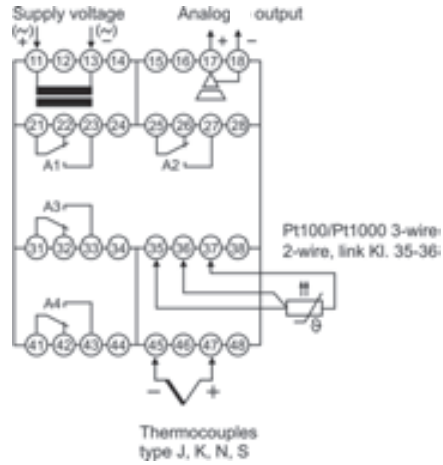

Ordering code

1. 2. 3. 4. 5. 6.
 TG50 - - - - - -

- 1. Device type/input**
 - 3 RTD Pt100, 3-wire, -100.0..+600.0 °C
 - RTD Pt1000, 3-wire, -100.0..+300.0 °C
 - Thermocouple
 - J (Fe-CuNi), -100.0..+800.0 °C
 - K (NiCr-Ni), -150..+1200 °C
 - N (NiCrSi-NiSi), -150..+1200 °C
 - S (Pt10Rh-Pt), -50..+1600 °C
- 2. Alarm output A1, A2**
 - 2R 2 relay SPDT
- 3. Alarm output A3, A4**
 - 00 not installed
 - 2R 2 relay SPDT
- 4. Analog output**
 - 00 not installed
 - AO 0/4..20 mA, 0/2..10 V DC, isolated
- 5. Supply voltage**
 - 0 230 V AC, ± 10 % 50-60 Hz
 - 1 115 V AC, ± 10 % 50-60 Hz
 - 5 24 V DC, ± 15 %
- 6. Options**
 - 00 without option

Temperature Guard TG50Ex



Characteristics

The Temperature Guard TG50Ex offers intrinsically safe inputs for direct connection of temperature probes RTD (Pt100, Pt1000) and thermocouples type J, K, N or S, which are installed in the explosion endangered area.

Simple programming, 2 alarm outputs (SPDT) and an optional available fully free programmable isolated analog output 0/4..20 mA; 0/2..10 V DC offers a lot of solutions for temperature monitoring. The peak value indication for minimum and maximum measured temperature are stored in the background and can be read out from the display at any time.

Technical data

Power supply

| | |
|--------------------------|---|
| Supply voltage | : 230 V AC ±10 %
115 V AC ±10 %
24 V DC ±15 %
Um = 253 V AC or 125 V DC
(terminals 11 and 13) |
| Power consumption | : max. 5 VA |
| Operating temperature | : -10..+55 °C |
| CE-conformity | : ATEX-directive 2014/34/EU
EN 60079-0:2006 EN 60079-11:2007
EN 61241-0:2006 EN 61241-11-0:2006 |
| EMC-directive / standard | : 2014/30/EU / EN 61326-1:2013 |

Inputs

| | |
|-------------------------|--|
| Explosions protection | : II (1) G [Ex ia] IIC/IIB or
II (1) D [Ex iaD] |
| Approval | : TÜV 08 ATEX 554329 |
| Fault detection | : broken line (Pt100/1000 and thermo-
couple) and short circuit (only
Pt100/1000) |
| Input RTD | : Pt100 (3-wire) -100.0..+600.0 °C
Pt1000 (3-wire) -100.0..+300.0 °C
(terminals 35, 36, 37) |
| Input TC | : Thermocouple
type J -100.0..+800.0 °C
type K -150..+1200 °C
type N -150..+1200 °C
type S -50..+1600 °C
cold junction compensation integrated
(terminals 45 and 47) |
| Accuracy | : <0.1 %, ±1 Digit |
| Temperature coefficient | : 0.01 %/K |

Safety data

| | |
|---|---------------|
| Max. voltage no load U ₀ | : 1,4 V |
| Max. short circuit curr. I ₀ | : 2.5 mA |
| Max. output power P ₀ | : 3 mW |
| Resistance R | : 5600 Ω |
| Characteristic curve | : trapezoidal |
| Internal inductivity | : 4 µH |
| Internal capacity | : 135 nF |

Explosion protection

| | | |
|---------------------------|------------------|---------------|
| | Ex ia/IIC | ia/IIB |
| Max. external inductivity | : 100 mH | 100 mH |
| Max. external capacity | : 25 µF | 120 µF |

Outputs

| | |
|------------------|--|
| Alarm outputs | : relay SPDT
< 250 V AC < 250 VA < 2 A
cos Phi ≥ 0.3
< 300 V DC < 40 W < 2 A
(terminals 21, 22, 23; 25, 26, 27) |
| Analog output | : 0/4..20 mA burden ≤ 500 Ω
0/2..10 V burden > 500 Ω, isolated
output changes automatically
(burden depending) |
| - Accuracy | : 0.2 %; TK 0.01 % / K
(terminals 17 and 18) |
| Fault function | : for broken line or short circuit detection
→ analog output (programmable)
0 mA, < 3.6 mA or >21.5 mA
→ alarm relays
min. or max. function programmable |
| Display | : graphic-LCD-display, 128 x 64 Pixel
with white LCD backlight |
| Case | : Polyamide (PA) 6.6, UL94V-0
TS35 acc. to DIN EN 60715 |
| Weight | : approx. 450 g |
| Connection | : screw terminals 0.14..2.5 mm ²
AWG 26..AWG14 |
| Protection class | : case IP30, terminals IP20 acc. to
BGV A3 |

Continue next page

Dimensions

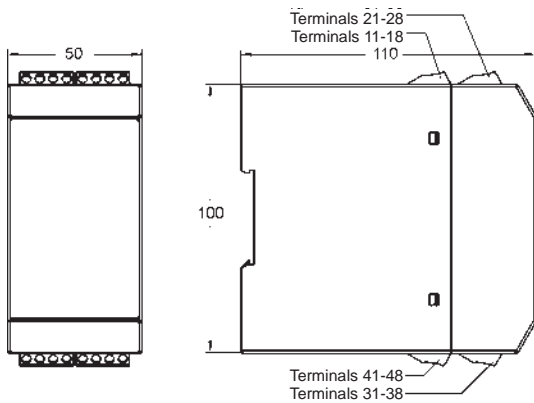

Connection diagram

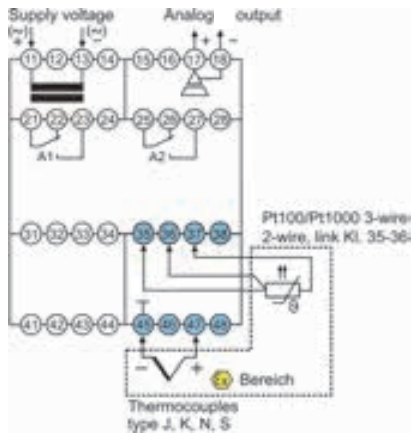

Ordering code

TG50Ex - 1. - 2. - 3. - 4. - 5. - 6.

| | | |
|--------------------------------|---|---|
| 1. Device type/input | 3 | RTD Pt100, 3-wire, -100.0..+600.0 °C
RTD Pt1000, 3-wire, -100.0..+300.0 °C
Thermocouple
J (Fe-CuNi), -100.0..+800.0 °C
K (NiCr-Ni), -150..+1200 °C
N (NiCrSi-NiSi), -150..+1200 °C
S (Pt10Rh-Pt), -50..+1600 °C |
| Inputs intrinsically safe | EX II (1) G [Ex ia] IIC/IIB
EX II (1) D [Ex iaD] | |
| 2. Alarm outputs A1, A2 | 2R 2 relay SPDT | |
| 3. Alarm outputs A3, A4 | 00 not available | |
| 4. Analog output | 00 not installed
AO 0/4..20 mA, 0/2..10 V DC, isolated | |
| 5. Supply voltage | 0 230 V AC, ± 10 % 50-60 Hz
1 115 V AC, ± 10 % 50-60 Hz
5 24 V DC, ± 15 % | |
| 6. Options | 00 without option | |

Temperature Controller TF1



- Installation location as desired
- Compact construction
- Normally opened or normally closed contact

Characteristics

A fully potted bimetal thermostat switches when a limit temperature is reached.

Technical data

| | | |
|----------------------------|---|--------------------|
| Switch | bimetal thermostatic switch | |
| Process connection | male thread G 1/2 A - optionally G 3/4 A (further process connections available on request) | |
| Switching value | +40..+120 °C in 10 °C steps.
The switching value is indicated for temperature increasing at 2 K/min. | |
| Tolerance | ±10 K | |
| Hysteresis | 10..20 K | |
| Pressure | PN 100 | |
| Medium temperature | Switch | Medium temperature |
| | 40 °C | -20..+ 90 °C |
| | 50 °C | -20..+100 °C |
| | 60 °C | -20..+110 °C |
| | 70 °C | -20..+120 °C |
| | 80 °C | -20..+130 °C |
| | from 90 °C | -20..+140 °C |
| Ambient temperature | -20..+70 °C | |
| Media | water, oils, gases | |
| Wiring | normally opened (n.o.)
No. 0.212 | |
| | normally closed (n.c.)
No. 0.214 | |
| Switching voltage | max. 250 V AC | |
| Switching current | max. 10 A | |
| Protection class | 1 - safety insulation | |
| Ingress protection | IP 65 | |

| | | |
|-------------------------------------|---|--------------------------------------|
| Electrical connection | plug DIN 43650-A / ISO 4400 | |
| Materials medium-contact | Brass construction: CW614N | Stainless steel construction: 1.4305 |
| Non-medium-contact materials | PA6.6, NBR | |
| Weight | G 1/2 A - 0.12 kg
G 3/4 A - 0.18 kg | |
| Installation location | Installation location as desired. When installed, the sensor (Ø8) should be fully immersed in the medium. | |

Dimensions

G 1/2 A

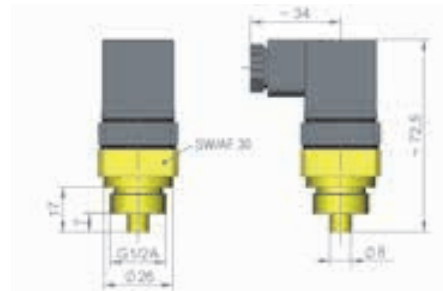

G 3/4 A (optional)

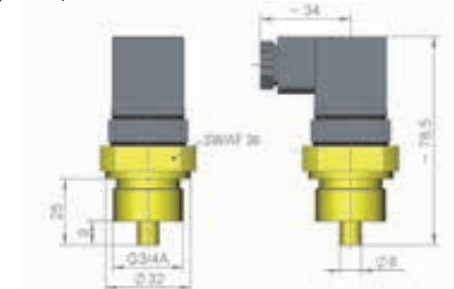

Ordering code

TF1 - 1. 2. 3. 4. H 5.

○=Option

| | | |
|-------------------------------|------------------------------|---------------------------------------|
| 1. Switching range | 040
..
120 | temperature 40..120 °C in 10 °C steps |
| 2. Connection material | M <input type="checkbox"/> | brass |
| | K <input type="checkbox"/> | stainless steel |
| 3. Connection | 015 <input type="checkbox"/> | thread G 1/2 A |
| | 020 <input type="checkbox"/> | thread G 3/4 A |
| 4. Process connection | H <input type="checkbox"/> | screw-in thread |
| 5. Wiring | S <input type="checkbox"/> | wiring 0.212 normally open (n.o.) |
| | O <input type="checkbox"/> | wiring 0.214 normally closed (n.c.) |

Options

- Signal lamp red

Temperature Controller TR



- Adjustable from the exterior
- Installation location as desired

Characteristics

The measurement fluid in the sensor expands as the temperature increases, and thus triggers a micro switch via a membrane.

Technical data

| | |
|-------------------------------------|--|
| Switch | micro switch |
| Process connection | male thread R 1/2" (DIN 2999) |
| Switching range | <i>one contact</i>
externally adjustable +50..+130 °C
<i>two contacts</i>
externally adjustable +35..+95 °C
internally adjustable +50..+130 °C |
| Adjustability | in 5 °C steps |
| Tolerance | ±5 K |
| Hysteresis | ~ 8 K |
| Pressure | PN 16 |
| Medium temperature | -20..+145 °C |
| Ambient temperature | -20..+55 °C |
| Media | water, viscous media, gases |
| Wiring | changeover No. 0.342
 |
| Switching voltage | 24..250 V AC |
| Switching current | max. 8 A (15 A ohmic load) |
| Switching capacity | at 24 V AC min. 150 mA |
| Protection class | 1 |
| Ingress protection | IP 43 (optionally IP 54) |
| Electrical connection | cable screw gland M20x1.5 |
| Materials medium-contact | CW614N nickelled (optionally stainless steel 1.4301) |
| Non-medium-contact materials | Cu nickelled, ABS |
| Weight | one contact 0.3 kg
two contacts 0.5 kg |
| Installation location | installation location as desired. When installed, the sensor should be fully immersed in the medium. |

Dimensions

one contact

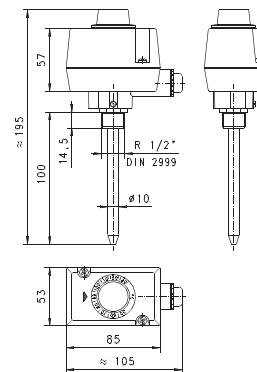

Further sensor lengths available on request.

two contacts

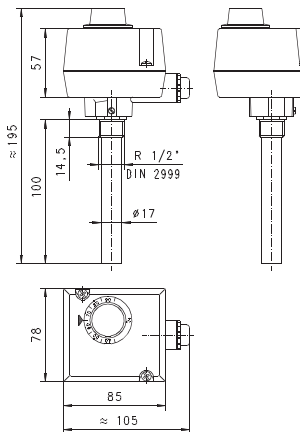

Further sensor lengths available on request.

Ordering code

TR - 1. 015 2. H 3. M 4.

| | | |
|-------------------------------|-----|----------------------------|
| 1. Connection size | 015 | threaded connection R 1/2" |
| 2. Process connection | H | screw-in thread |
| 3. Connection material | M | brass |
| 4. Number of contacts | 1 | one contact |
| | 2 | two contacts |

Options

- Immersion sleeve 200 mm
- Immersion sleeve 280 mm
- Immersion sleeve stainless steel
- Ingress protection IP 54

Thermal Limiter TB225

(in accordance with DIN EN 14597)



- Can be used as a temperature limiter and monitor
- Certified in accordance with DIN EN 14597
- adapted for all sensors according to DIN EN14597
- Pt100 inputs, dual thermocouple, input signals
- 2 changeover relays
- Configuration via backlit graphic display
- 'White / Red' display colour change in the case of an alarm
- Safe galvanic isolation between input / output / auxiliary voltage
- Automatic recognition of the output signal
- Wide-range mains adapter
- Carrier rail mounting TS 35

Characteristics

The temperature limiter TB225 is used for applications where thermal processes must be monitored and the system must be switched to a safe operating state in the case of a fault. The device has universal inputs for the connection of dual thermocouples, Pt100 sensors, and input signals (0/4..20mA or 0/2..10V). The safety function is provided by means of the main relay with configurable threshold. An additional relay with an independently adjustable threshold is provided for additional signalling. The TB225 also offers an analog output which can be freely defined within the measuring range of the temperature input. The resetting of the device in the operating mode as a temperature limiter can take place via the buttons on the front, the integrated graphic display, or using an external switch or external voltage. The TB225 has safe 3-way electrical isolation between input, output, and auxiliary voltage.

Brief information

The connected temperature signal is evaluated and monitored. If the permissible threshold is reached or an error occurs within the permissible temperature range, the TB225 switches off immediately. The additional relay output of the TB225 enables the function of a preliminary alarm with an independent threshold. TB225 is adapted for the use with all sensors according to EN14597.

The following operating modes are possible through configuration:

Temperature limiter:

Maximum or minimum monitoring with catch, manual resetting after fault elimination via the front keys or an external switch / voltage signal.

Operating methods in accordance with EN14597: 02/2015: Type 2B, 2H, 2V

Temperature monitor:

Maximum or minimum monitoring without catch, automatic resetting on return to the permissible range.

Operating methods in accordance with EN 14597: 02/2015: Type 2B

Technical data

Auxiliary power

Auxiliary voltage : 18 – 230 V AC/DC
 Power consumption : < 5 VA
 Rated voltage : 250V AC in accordance with EN 60730-1: 10/2012, between input / relay output / auxiliary voltage, Degree of contamination 2, Overvoltage category III
 Rated surge voltage 4kV

CE Conformity : EN 14597 02/2015
 EN 61326: 07/2013

Environmental conditions

Operating temperature : -10..+55 °C
 storage temperature : -20..+60 °C
 Relative air humidity : < 95 %
 Condensation : not permitted

Approvals

DIN EN 14597: 02/2015 : Temperature control devices and temperature limiters for heat generating systems

Input

Pt100 : -100.0..600.0°C
 Accuracy : 0,2%, ±1 Digit
 Temperature coefficient : 0,01%/K
 Thermocouple : Type J:Fe-CuNi-100..800°C
 Type K: NiCr-Ni -150..1200°C
 Type N: NiCrSi-NiSi -150..1200°C
 Type S:Pt10RH-PT 0..1600°C
 Reference junction compensation integrated

Accuracy: : <0.3 %, ±1 digit

Temperature coefficient : 0.01 %/K

Analog input : 0/2..10 V DC, 0/4..20 mA
 0..10 V und 0..20 mA not allowed for temperature limiter

Accuracy : 0,2%, ±1 Digit

Temperature coefficient : 0,01%/K

Display

: graphic LC display with 32 x 90 pixel, with white/red background lighting

Outputs

Switching outputs : 2 x relay
 Changeover relay : < 250 V AC < 500 VA < 2 A ohmic load
 < 30 V DC < 60W < 2 A ohmic load
 Internal main relay secured with 2A fuse!
 Fuse is not interchangeable!

Analog output : 0/4..20 mA load ≤ 500 Ω
 0/2..10 V DC load > 500 Ω electrically isolated.

Output switches automatically (load-dependent)

Housing : polyamide (PA) 6.6 , UL94V-0, TS35 in accordance with DIN EN 60715

Weight : approximately 180 g

Connection : screw terminals 0.14..2.5 mm² with wire protection 0.14 - 2.5 mm² (AWG 26 - 14)

Protection rating : IP20, BGV A3

Dimensions

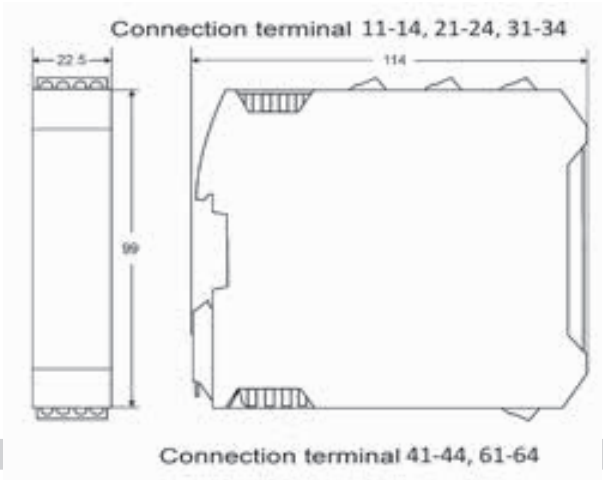

Ordering code

TB225 - - - -

| | | |
|-----------------------------|----|--------------------------------------|
| 1. Version/input | 0 | Universal input |
| 2. Output | 0 | 2 relay / 1 analog output 0/4..20 mA |
| 3. Auxiliary voltage | 0 | 18 – 230 V AC/DC |
| 4. Options | 00 | without option |
| | 01 | Push-in terminal block |

Connection diagram

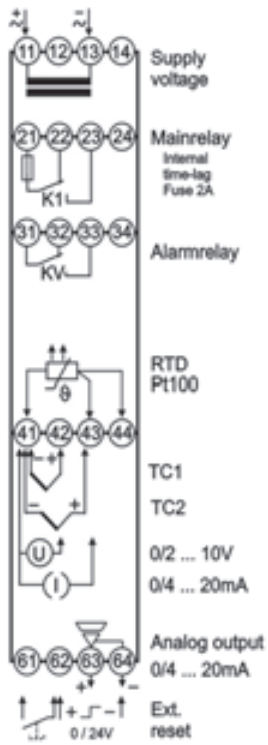

Safety Temperature Limiter STL50

(acc. to DIN EN 14597, SIL 2)



- Useable as Temperature Limiter/-Guard and Exhaust gas Temperature Limiter
- Certified according to DIN EN 14597 SIL2
- Inputs RTD Pt100 or double-thermocouple
- Limit value and switching hysteresis programmable
- Basic accuracy < 0.5%, ± 2 digit
- Reaction time ≤ 0.5 s
- 1 Relay for safety-relevant temperature limit, forcibly guided
- 1 Relay for pre-alarm
- Analogue output 0/4... 20mA; 0/2... 10 VDC
- Memory function for error message
- Operator lock (password protection)
- Contact input for external reset
- 24 V DC signal for external alarm message

Characteristics

The STL50 safety temperature limiter is used where ever thermal processes must be monitored and the system must be transferred into a safe operational state in case of fault. If the permissible temperature limit value is reached, or if a fault occurs within the permissible temperature range on the monitoring equipment (sensor open, sensor short-circuit, failure of a component part in the device, fault in the software, failure or inadmissible value of the supply voltage etc.), the STL50 switches off without delay.

The alarm contact is activated, the LED ALARM on the front panel and the back-lighting of the display light up, and the error cause is indicated as plain text on the display. In addition, there is a 24 V DC signal present on the terminals 16-17 for an external alarm signal. Alternatively, the device can be reset using an external contact. In addition, the STL50 optionally has an programmable analog output with up or downscaling function, as well as a precontact.

Description

Programming

The device is programmable via front side buttons in connection with the graphic display.

Operating modes

The device can be used as:

STB → Maximum- or minimum-monitoring with hold. Reset possible after omission of the fault with the external or internal button.

ASTB → as before, but monitoring the exhaust gas temperature

STW → Maximum- or minimum-monitoring without hold.

Automatic reset after leaving the dangerous range

Switching hysteresis always acts in the direction of safe range.

The last fault is stored as plain text and can be called up in the working level and deleted.

Temperature sensor

When using the device according to DIN EN 14597, temperature sensors which are approved according to DIN EN 14597 must be used!

Technical data

Power supply

Supply voltage : 230 V AC ±10 %
115 V AC ±10 %
24 V DC ±15 %

Power consumption : < 4 VA

CE-conformity : EN 61326-1: 2013
EN 61326-2-2: 2013

Ambient conditions

Operating temperature : -10..+55 °C
Storage temperature : -30..+60 °C
Relative humidity : < 95 %
Condensation : not permitted
Vibrations : operation only in vibration less ambient

Approvals

EN 14597:2012 : Temperature control devices and temperature limiters for heatgenerating systems
EN 61508:2011 SIL2 : Functional security safety-related electrical/electronic/programmable electronic systems

Input

Pt100 : in the range -100,0..+600,0 °C
3-wire,
max. line resistance 4 Ω
each line
sensor current <1 mA
(non self heating)

Thermocouple

Typ J : Fe-CuNi, -100,0..+800,0 °C
Typ K : NiCr-Ni,-150..+1200 °C
Typ N : NiCrSi-NiSi, -150..+1200 °C
Typ S : Pt10Rh-Pt, 0..+1600 °C

cold junction compensation integrated

Accuracy : <0,5 %, ±2 Digit
Temperature coefficient : 0,01 %/K
Display : graphic-LCD-display 28 x 64 Pixel,
with white LCD-backlight

Outputs

Main relays : SPDT
<250 V AC <200 VA <2 A cosφ ≥ 0,7;
<250 VDC <80 W <2 A, forcibly guided,
internal fuse 2 A (slow-blow)

Pre-alarm relays : SPDT <250 V AC <500 VA <2 A ohmic load;
<30 VDC <60 W <2 A,

Analogue output : 0/4 ... 20mA burden ≤500Ω; 0/2 ... 10V burden > 500Ω, galvanically isolated
Output automatically changing (burdendependend)

Accuracy

(analogue output) : 0,4 %; TK: 0,01% /K
Case : Polyamide (PA) 6.6, UL94V-0,
TS35 according to DIN EN 60715

Weight

Connection : approx. 450 g
: screw terminals 0,14..2,5 mm²
(AWG 26 .. 14)

Protection class : IP20, DIN EN 60529, BGV A3

Dimensions

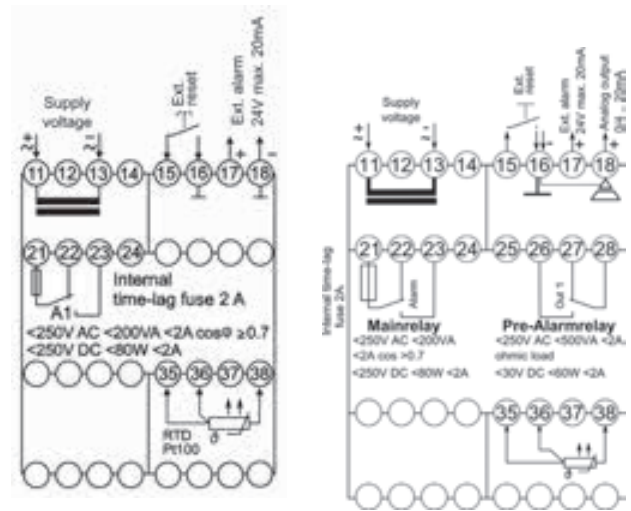
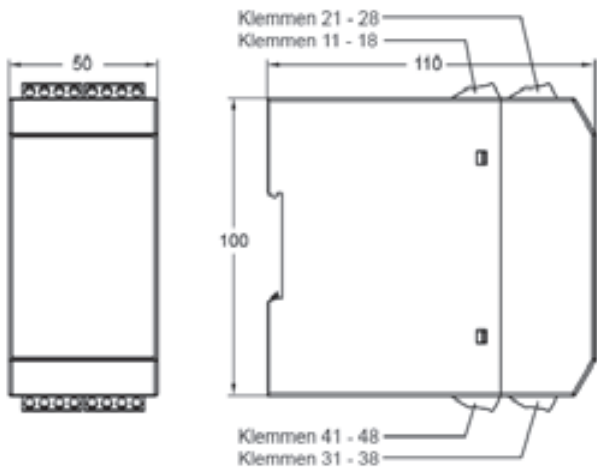

Pt100-1R

Pt100-2RAO

Connection diagrams

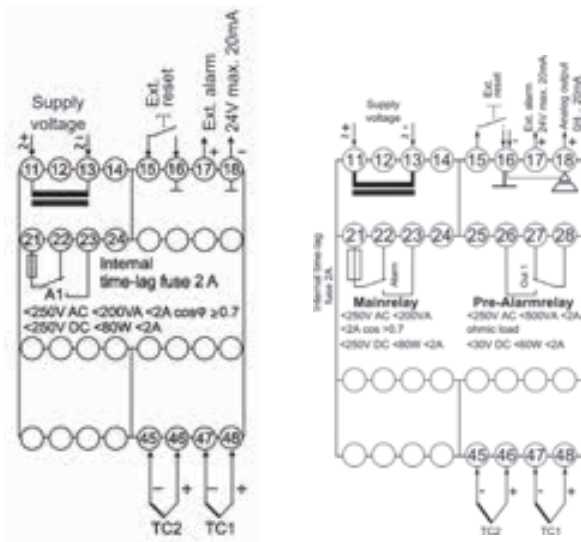

Thermocouple 1R

Thermocouple 2RAO

Accessories:

Temperature sensor

- When using STL50 as safety limiter -or guard- according to EN14597, safety temperature sensors acc. To 14597 have to be used: See our products TR296/293, TC296/293
- Temperature sensor for SIL applications: Temperature sensors without transducers are passive elements and not SIL-classified. All sensors of our portfolio can be used. PFD characteristics for resistance elements or thermocouples are to be found in the standard tables. Alternatively manufacturer declarations of evaluation electronics and sensors to the SIL level can be created on request.

Ordering code

STL50 - - - -

| | |
|-----------------------------|---|
| 1. Device type/input | |
| 1 | Pt100, 3-wire, -100,0..+600,0 °C |
| 5 | Thermocouple
J (Fe-CuNi), -100,0..+800,0 °C
K (NiCr-Ni), -150..+1200 °C
N (NiCrSi-NiSi), -150..+1200 °C
S (Pt10Rh-Pt), 0..1600 °C |
| 2. Output | |
| 1R | 1 alarm output, relay SPDT |
| 2RAO | 2 relay SPDT + analogue output |
| 3. Supply voltage | |
| 0 | 230 V AC, ± 10 % 50-60 Hz |
| 1 | 115 V AC, ± 10 % 50-60 Hz |
| 4 | 24 V AC, ± 15 % 50-60 Hz |
| 5 | 24 V DC, ± 15 % |
| 4. Options | |
| 00 | Without option |

Safety Temperature Limiter STL50Ex

(acc. to DIN EN 14597, SIL 2)



- Useable as Temperature Limiter/-Guard and Exhaust gas Temperature Limiter
- Certified according to DIN EN 14597 SIL2
- Intrinsically safe input for use with temperature sensors in 0/20; 1/21; 2/22
- Inputs RTD Pt100 or double-thermocouple
- Limit value and switching hysteresis programmable
- Basic accuracy < 0.5%, ± 2 digit
- Reaction time ≤ 0.5 s
- 1 Relay for safety-relevant temperature limit, forcibly guided
- 1 Relay for pre-alarm
- Analogue output 0,4..20mA; 0/2..10 VDC
- Memory function for error message
- Operator lock (password protection)
- Contact input for external reset
- 24 V DC signal for external alarm message

Characteristics

The STL50Ex safety temperature limiter is used where ever thermal processes must be monitored and the system must be transferred into a safe operational state in case of fault. If the permissible temperature limit value is reached, or if a fault occurs within the permissible temperature range on the monitoring equipment (sensor open, sensor short-circuit, failure of a component part in the device, fault in the software, failure or inadmissible value of the supply voltage etc.), the STL50Ex switches off without delay. The alarm contact is activated, the LED ALARM on the front panel and the back-lighting of the display light up, and the error cause is indicated as plain text on the display. In addition, there is a 24 V DC signal present on the terminals 16-17 for an external alarm signal. Alternatively, the device can be reset using an external contact. In addition, the STL50Ex optionally has an programmable analog output with up or downscaling function, as well as a precontact.

Description

Programming

The device is programmable via front side buttons in connection with the graphic display.

Operating modes

The device can be used as:

- STB → Maximum- or minimum-monitoring with hold. Reset possible after omission of the fault with the external or internal button.
- ASTB → as before, but monitoring the exhaust gas temperature
- STW → Maximum- or minimum-monitoring without hold. Automatic reset after leaving the dangerous range.

Switching hysteresis always acts in the direction of safe range. The last fault is stored as plain text and can be called up in the working level and deleted.

Temperature sensor

When using the device according to DIN EN 14597, temperature sensors which are approved according to DIN EN 14597 must be used!

Technical data

Power supply

| | |
|-------------------|---|
| Supply voltage | : 230 V AC ±10 %
115 V AC ±10 %
24 V DC ±15 % |
| Power consumption | : < 4 VA |
| CE-conformity | : EN 61326-1: 2013
EN 61326-2-2: 2013 |

Ambient conditions

| | |
|-----------------------|---|
| Operating temperature | : -10..+55 °C |
| Storage temperature | : -30..+60 °C |
| Relative humidity | : < 95 % |
| Condensation | : not permitted, operation only in vibration less ambient |

Approvals

| | |
|--------------------|--|
| EN 14597:2005 | : temperature control devices and temperature limiters for heat-generating systems |
| EN 61508:2001 SIL2 | : Functional security safety-related electrical/electronic/programmable electronic systems |

Input

| | |
|----------------------|---|
| Explosion protection | : II (1) G [Ex ia] IIC/IIB or II (1) D [Ex ia Da] IIIC |
| Approval | : TÜV 07 ATEX 554295 |
| Pt100 | : -100.0..+600.0 °C, 3-wire, 3-wire, max. line resistance 4 Ω each line, sensor current<1 mA (non self heating) |

Data in case of an error

| | |
|---|------------------------------|
| Max. voltage no load U ₀ | : 1.4 V |
| Max. short circuit current I ₀ | : 6 mA |
| Max. power loss P ₀ | : 7 mW |
| Min. internal resistor R | : 1.6 kΩ (curve trapezoidal) |

Explosion protection

| | | |
|---------------------------|------------------|---------------|
| | Ex ia/IIC | ia/IIB |
| Max. external inductivity | : 100mH | 20mH |
| Max. external capacity | : 110µF | 28 µF |
| Internal capacity | : negligible | |
| Internal inductivity | : negligible | |

Thermocouple

| | |
|--------|--|
| Type J | : Fe-CuNi, -100.0..+800.0°C |
| Type K | : NiCr-Ni, -150..+1200 °C |
| Type N | : NiCrSi-NiSi, -150..+1200°C |
| Type S | : Pt10Rh-Pt, 0..1600 °C
cold junction compensation integrated |

Data in case of an error

| | |
|---|----------------------------|
| Max. voltage no load U ₀ | : 0.7 V |
| Max. short circuit current I ₀ | : 2 mA |
| Max. power loss P ₀ | : 1.5 mW |
| Min. internal resistor R | : 5 kΩ (curve trapezoidal) |

Explosion protection

| | | |
|---------------------------|------------------|---------------|
| | Ex ia/IIC | ia/IIB |
| Max. external inductivity | : 100mH | 50mH |
| Max. external capacity | : 240µF | 54 µF |
| Internal capacity | : negligible | |
| Internal inductivity | : negligible | |

| | |
|-------------------------|---|
| Accuracy | : <0.5 %, ±2 Digit |
| Temperature coefficient | : 0.01 %/K |
| Display | : graphic LCD-display 28 x 64 Pixel, with white LCD-backlight |

Continue next page >

Product information Flow - Temperature

| | |
|-----------------------------------|---|
| Output Relay | : SPDT
<250 V AC <200 VA <2 A
cos Phi ≥0.7
<250 VDC <80 W <2 A,
internal fused 2 A (slow-blow) |
| Pre-alarm relays | : SPDT <250 V AC <500 VA <2 A
ohmic load; <30 VDC <60 W <2 A, |
| Analogue output | : 0/4 ... 20mA burden ≤500Ω; 0/2..10V
burden > 500Ω, galvanically isolated
Output automatically changing
(burdendependend) |
| Accuracy (analogue output) | : 0,04 %; TK: 0,01% /K |
| Case | : Polyamide (PA) 6.6 , UL94V-0,
TS35 acc. to DIN EN 60715 |
| Weight | : approx. 450 g |
| Connection | : screw terminals 0.14..2.5 mm ²
(AWG 26 .. 14) |
| Protection class | : IP20, DIN EN 60529, BGV A3 |

Ordering code

STL50Ex - - - -

1. 2. 3. 4.

| | |
|-----------------------------|---|
| 1. Device type/input | |
| 1 | Pt100, 3-wire, -100.0..+600.0 °C |
| 5 | Thermocouple
J (Fe-CuNi), -100.0..+800.0 °C
K (NiCr-Ni), -150..+1200 °C
N (NiCrSi-NiSi), -150..+1200 °C
S (Pt10Rh-Pt), 0..1600 °C |
| 2. Output | |
| 1R | 1 alarm output relay |
| 2RAO | 2 relay outputs + analog output |
| 3. Supply voltage | |
| 0 | 230 V AC, ± 10 % 50-60 Hz |
| 1 | 115 V AC, ± 10 % 50-60 Hz |
| 5 | 24 V DC, ± 15 % |
| 4. Options | |
| 00 | without option |

Dimensions

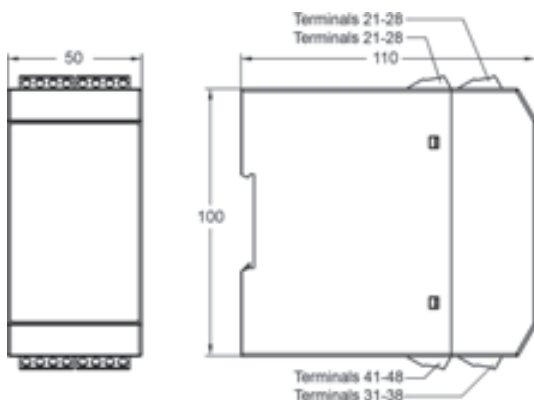

Connection diagrams

Pt100

with pre-alarm / analog

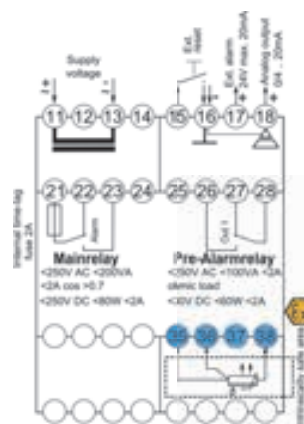

without pre-alarm / analog

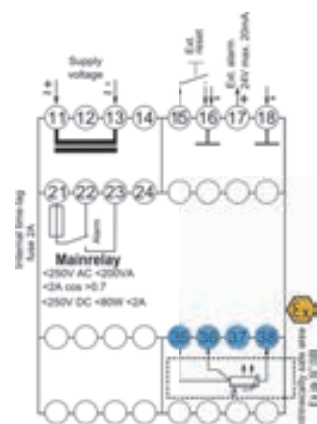

Thermo

with pre-alarm / analog

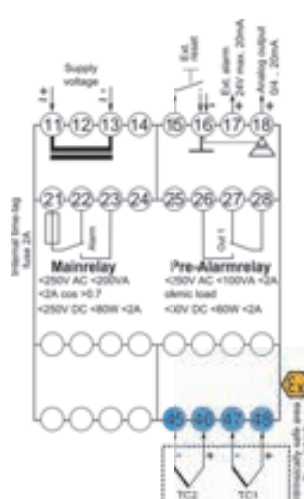

without pre-alarm / analog

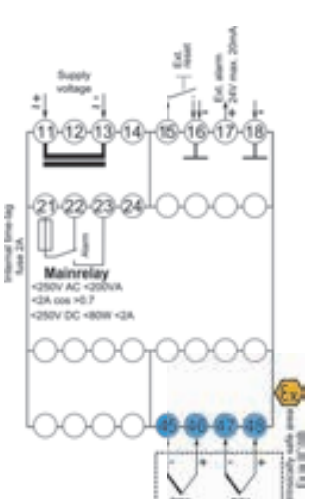

Accessories

Temperature sensor

- When using STL50Ex as safety limiter -or guard according to EN14597, safety temperature sensors acc. To 14597 have to be used: See our products TR296/293, TC296/293

- Temperature sensor for SIL applications: Temperature sensors without transducers are passive elements and not SIL-classified. All sensors of our portfolio can be used. PFD characteristics for resistance elements or thermocouples are to be found in the standard tables. Alternatively manufacturer declarations of evaluation electronics and sensors to the SIL level can be created on request.

Temperature Limit Value Relay GS1000



Dimensions

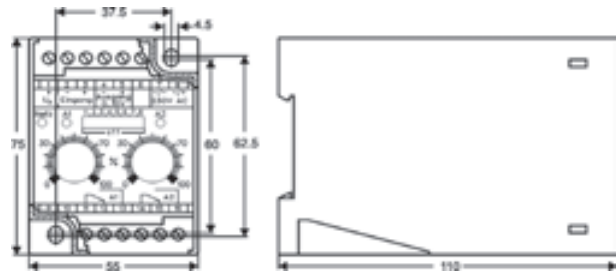

Characteristics

The monitoring device GS1000 can be used for monitoring of temperatures in process and automation systems.

Technical data

Power supply

- Supply voltage : $U_c \pm 10\%$
- Frequency : 47..63 Hz
- Power consumption : 4 VA
- Operating temperature : -10..+60 °C
- CE - conformity : EN 61326-1:2013; EN 60664-1:2007

Input

- RTD Pt100 : sensor current 1 mA
- Thermocouple : $R_i > 1\text{ M}\Omega$
- Switching hysteresis : approx. 1 %
- Scale accuracy : 2 %
- Repeatability : 0.2 %
- Accuracy : RTD Pt100 0.7 %
Thermocouple 0.3 % non linearized

Temperature coefficient

- Pt100 / Thermocouple : 0.035 %/K

Outputs

- Limit relay : 250 V AC < 250 VA < 2 A
100 V DC < 50 W < 1 A

True value

- Voltage : 0..10 V DC, max, 10 mA
- Current (optional) : 0..20 mA or 4..20 mA, burden max. 500 Ω

Case

- : Polycarbonate UL94V-0 acc. to DIN EN 60715:2001-09

Weight

- : approx. 400 g

Electrical connection

- : Screw terminals with pressure plate, max. 4 mm²

Protection class

- : case IP40, terminals IP20 BGV A3

Connection diagrams

Pt100 scale °C

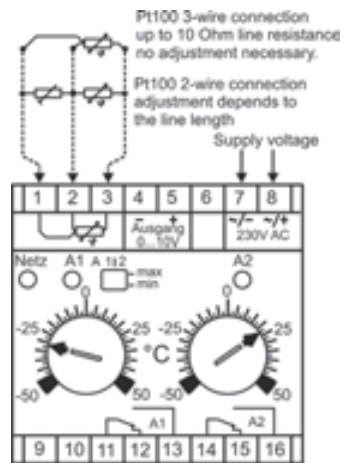

Thermocouple scale °C

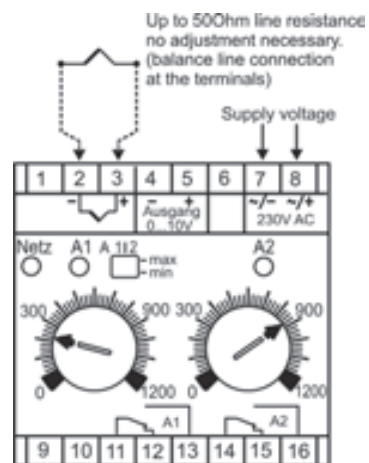

Continue next page

Ordering code

GS1000 - - - -

1. 2. 3. 4.

| | |
|----------------------------------|-------------------------------|
| 1. Limit contact (SPDT) | |
| 1 | 1 contact max. 250 V AC/2 A |
| 2 | 2 contacts max. 250 V AC/2 A |
| 2. True value output | |
| 1 | 0..10 V (max. 10 mA) standard |
| 2 | 0..20 mA burden max. 500Ω |
| 3 | 4..20 mA burden max. 500Ω |
| 3. Supply voltage | |
| 0 | 230 V ±10 % 50-60Hz |
| 5 | 20..28 V DC isolated |
| 4. Measuring input /scale | |
| 51 | Pt100, -50..+50 °C |
| 52 | Pt100, 0..50 °C |
| 53 | Pt100, 0..100 °C |
| 535 | Pt100, 0..150 °C |
| 54 | Pt100, 0..200 °C |
| 55 | Pt100, 0..300 °C |
| 56 | Pt100, 0..400 °C |
| 57 | Pt100, 0..600 °C |
| 61 | Fe-CuNi (J), 0..300 °C |
| 62 | Fe-CuNi (J), 0..450 °C |
| 63 | Fe-CuNi (J), 0..600 °C |
| 71 | NiCr-Ni (K), 0..600 °C |
| 72 | NiCr-Ni (K), 0..900 °C |
| 73 | NiCr-Ni (K), 0..1200 °C |
| 81 | PtRh-Pt (S), 0..1200 °C |
| 82 | PtRh-Pt (S), 0..1600 °C |

Temperature-Meter T1010



- Measuring input Pt100 -100.0..+600.0 °C
Pt1000 -50.0..+200.0 °C
- LED-Display 14.2 mm red, indicating range ±9999(0) Digit
- Max. 2 alarm outputs, relay SPDT
- Analog output 0/4..20 mA, 0/2..10 V
- Field case with snap lid, 2 x M16x1.5

Characteristics

The Temperature-Meter T1010 is suitable for measurement of temperatures in connection with RTD sensors Pt100, Pt1000. Devices for other temperature sensors are available on request. The measuring input is isolated. The measuring range can be limited in the configuration level. This is identical with the range of the analog output.

Technical data

Power supply

Supply voltage : 230 V AC ±10 %; 115 V AC ±10 %,
24 V AC ±10 % or 24 V DC ±15 %

Power consumption : max. 3.5 VA

Operating temp. : -20..+55 °C

CE-conformity : EN 61326-1:2013
EN 60664-1:2007

Input

Pt100; Pt1000 : -100..+600 °C ; -50..+200 °C

Accuracy : Pt100 or Pt1000 < 0.1% ±2 Digit,
max. 100 Ω line resistance

Display

: LED red, 14.2 mm
Indicating range : ±9999(0) digit, with leading zero suppression
Additional display : LED 2-digit red, 7 mm
(Parameter - and output indicator)

Output

Relay : SPDT < 250 V AC < 250 VA < 2 A,
< 300 V DC < 50 W < 2 A

Analog : 0/4..20 mA burden ≤ 500 Ω; 0/2..10 V
burden > 500 Ω, **no** isolation,
automatic output changing
(burden dependent)

- Accuracy : 0.1 %; TK 0.01 %/K

Field case : Material PA6-GF/GFK 15/15

Dimensions : 100x100x60 mm

Weight : max. 450 g

Cable gland : 2 x M16x1.5

Connection : clamp terminals, 0.08..1.5 mm²,
AWG28..AWG14

Protection class : front IP65, terminals IP20 acc. to BGV A3

Dimensions

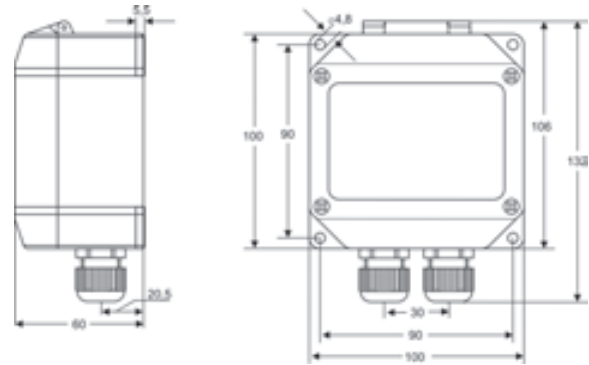

Connection diagram

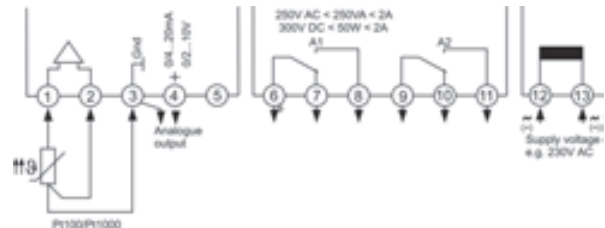

Ordering code

T1010 - 1. - 2. - 3. - 4. - 5. - 6. - 7.

| 1. Input | | |
|--|--|------------------|
| 1 | Pt100 | -100.0..+600.0°C |
| 3 | Pt1000 | -50.0..+200.0°C |
| 2. Alarm output | | |
| 00 | not installed | |
| 2R | 2 relay SPDT | |
| 3. Analog output | | |
| 00 | not installed | |
| AO | analog output 0/4..20 mA, 0/2..10 V DC | |
| 4. Supply voltage | | |
| 0 | 230 V AC | ±10 % 50-60Hz |
| 1 | 115 V AC | ±10 % 50-60Hz |
| 4 | 24 V AC | ±10 % 50-60Hz |
| 5 | 24 V DC | ±15 % |
| 5. Options | | |
| 00 | without option | |
| 01 | min-max-value hold | |
| 07 | display brightness programmable | |
| 09 | 1xM20x1.5 multi (2xØ 6 mm), 1xM20x1.5 | |
| 6. Unit (appears in the unit field) | | |
| 7. Additional text above the display (3x70 mm HxW) | | |

Temperature Panelmeter T9648



- Measuring input for Pt100, Pt1000 or Thermocouple
- LED-Display 14.2 mm red
- Max. 4 alarm outputs relay SPDT or transistor

Characteristics

The Temperature Panelmeter T9648 is suitable for measurement of temperatures in connection with RTD sensors Pt100, Pt1000 and thermocouples Fe-CuNi (J), NiCr-Ni (K), Pt10Rh-Pt (S). Devices for other temperature sensors are available on request. The measuring input is isolated. The measuring range can be limited in the configuration level. It is identical with the range of the analog output.

Technical data

Power supply

Supply voltage : 230 V AC $\pm 10\%$; 115 V AC $\pm 10\%$;
24 V AC $\pm 10\%$ or 24 V DC $\pm 15\%$

Power consumption : max. 3.5 VA, with analog output 5 VA

Operating temp. : -10..+55 °C

CE- conformity : EN 61326-1:2013
EN 60664-1:2007

Input

Pt100 : -100..+600 °C

Pt1000 : -50..+200 °C

Accuracy : Pt100 or Pt1000 $< 0.1\% \pm 2$ Digit,
max. 100 Ohm line resistance

Thermocouple : Fe-CuNi (J) 0..+800 °C,
NiCr-Ni (K) 0..+1200 °C
Pt10Rh-Pt (S) 0..+1600 °C
built-in cold junction

Accuracy : $< 0.1\% \pm 2$ Digit with compensating line

Display : LED red, 14.2 mm

Indicating range : $\pm 9999(0)$ Digit

Parameter display : LED 2-digit red, 7 mm
(parameter - and output indicator)

Output

Relay SPDT : < 250 V AC < 250 VA < 2 A,
 < 300 V DC < 50 W < 2 A

Transistor : max. 35 V AC/DC, 100 mA,
short circuit protected

Analog output : 0/4..20 mA burden $\leq 500 \Omega$; 0/2..10 V
burden $> 500 \Omega$, isolated
automatic output changing
(burden depending)

- Accuracy : 0.1 %; TK 0.01 %/K

Case : panel case DIN 96x48 mm,
material PA6-GF; UL94V-0

Dimensions : front 96x48 mm, mounting depth 100 mm

Weight : max. 390 g

Connection : clamp terminals, 0.08..1.5 mm²
AWG28..AWG14

Protection class : front IP65, terminals IP20 acc. to BGV A3

Dimensions

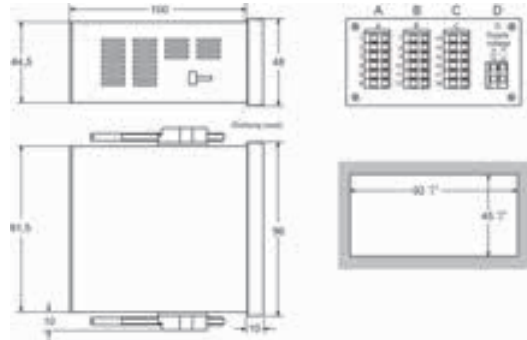

Connection diagram

Pt100/Pt1000

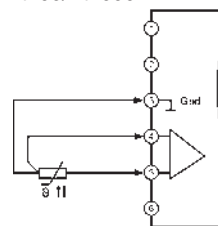

Thermocouples

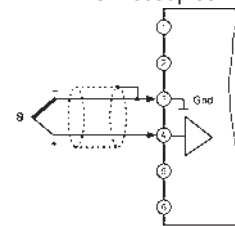

Order code

T9648 - - - - - - -

| 1. Terminal strip A | |
|---|---|
| 1 | input Pt100 |
| 3 | input Pt1000 |
| 5 | input thermocouple |
| 2. Terminal strip B | |
| 00 | not installed |
| 2R | 2 relay outputs |
| 2T | 2 electronic outputs |
| T1* | 2 nd input Pt100 |
| T3* | 2 nd input Pt1000 |
| 3. Terminal strip C | |
| 00 | not installed |
| 2R | 2 relay outputs |
| 2T | 2 electronic outputs |
| AO | analog output 0/4..20 mA, 0/2..10 V |
| 4. Terminal strip D; supply voltage | |
| 0 | 230 V AC $\pm 10\%$ 50-60Hz |
| 1 | 115 V AC $\pm 10\%$ 50-60Hz |
| 4 | 24 V AC $\pm 10\%$ 50-60Hz |
| 5 | 24 V DC $\pm 15\%$ |
| 5. Options | |
| 00 | without option |
| 01 | min-and max-peak hold |
| 02 | difference-, average-, larger-, smaller value |
| 07 | display brightness programmable |
| 6. Unit (appears in the unit field) | |
| 7. Additional text placed above the display (3x90 mm HxW) | |

*In connection with terminal strip A, only Pt100 or Pt1000; Pt100 and Pt1000 can not be mixed. Not isolated to terminal strip A. Input ranges of Input 1 and 2 have to be the same. Only available with option 02.

Connection Diagrams X9648, Terminals B-D

Terminal strips B, C, D

Terminal strip A belongs to each article.

Terminal strip B (varies with versions)
2 alarm outputs

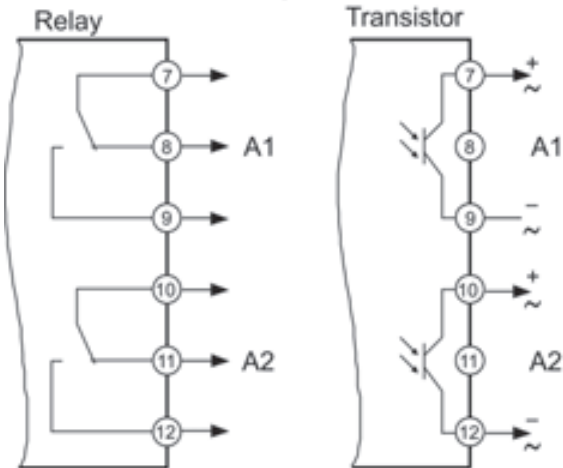

Terminal strip C (varies with versions)
2 alarm outputs

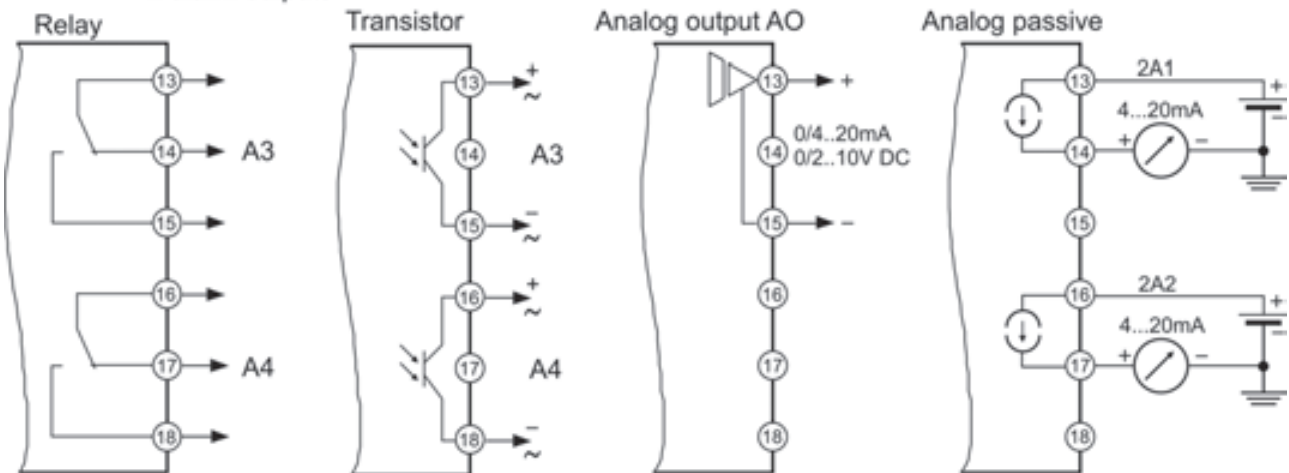

Terminal strip D supply voltage (varies with version)



Accessories

Cables and lines

Extension cable VKA

Extension cable, NiCr-Ni
Silicon compensation cable with DIN-plug and DIN-coupler

1.
VKA -

| 1. Cable length | |
|-----------------|--------------|
| 1m | 1 meter long |
| 2m | 2 meter long |

Silicon cable

Silicone cable with Teflon screened leads (max. 200°C)
S2P: silicone cable, 2-pole (2 x 0.25 mm²) highly flexible
S4P: silicone cable, 4-pole (4 x 0.14 mm²) insulation 2x blue, 2x white

1. 2.
S P -

| 1. Number of leads | |
|--------------------|-------------------------------------|
| 2 | 2-pole cable |
| 4 | 4-pole cable |
| 2. Cable length | |
| xx | desired length in m (e.g. 04 = 4 m) |

Glass silk insulated cable

Glass silk insulated cable with stainless steel braiding
(max. 400°C), 2-, 3- or 4-pole (0.22 mm²)

1. 2.
G P -

| 1. Number of leads | |
|--------------------|-------------------------------------|
| 2 | 2-pole cable |
| 3 | 3-pole cable |
| 4 | 4-pole cable |
| 2. Cable length | |
| xx | desired length in m (e.g. 04 = 4 m) |

Teflon insulated cable

Teflon cable with Teflon isolated leads
(max. 250°C), 2-, 3- or 4-pole (0.14 mm²)
T3P and T4P with additional shielding

1. 2.
T P -

| 1. Number of leads | |
|--------------------|-------------------------------------|
| 2 | 2-pole cable |
| 3 | 3-pole cable |
| 4 | 4-pole cable |
| 2. Cable length | |
| xx | desired length in m (e.g. 04 = 4 m) |

PVC-line

PVC-line (max. 70°C), 2-, 3- or 4-pole (0.14 mm²)

1. 2.
P P -

| 1. Number of leads | |
|--------------------|-------------------------------------|
| 2 | 2-pole cable |
| 4 | 4-pole cable |
| 2. Cable length | |
| xx | desired length in m (e.g. 04 = 4 m) |

Compensation lines

AGL1: Silicone cable (2 x 0.22 mm²) max. 200°C
AGL3: Thermo wire (can also be used as thermocouple)
glass silk, (2 x 0.5 mm²) max. 400°C
AGL4: Teflon screened twisted thermo wire,
(wire-Ø 0.2 mm) max. 250°C
AGL5: Thermo wire with glass silk braiding,
(wire-Ø 0.2 mm) max. 400°C
AGL6: Teflon cable, screened – can also be used as thermo-
couple, (2 x 0.22 mm²), max. 250°C

1. 2.
AGL - -

| 1. Type | |
|-----------------|-------------------------------------|
| 1 | as per description |
| 3 | as per description |
| 4 | as per description |
| 5 | as per description |
| 6 | as per description |
| 2. Cable length | |
| xx | desired length in m (e.g. 04 = 4 m) |

Product information Flow - Temperature

Round plug connector

Round plug connector 4-pin



- 1 → brown
- 2 → white
- 3 → blue
- 4 → black

Ordering code

Self-assembly

1.

KB04

| 1. Connector output | |
|---------------------|------------|
| G | straight |
| W | elbow 90 ° |

Packaged

1. 2. 3. 4. 5.

K PU -

| | |
|----------------------------|-----------------------------------|
| 1. Cable material | |
| PU | PUR |
| 2. Cable length | |
| 02 | 2 m |
| 05 | 5 m |
| 10 | 10 m |
| 3. Shielding | |
| N | shielding not applied to coupling |
| S | shielding applied to coupling |
| 4. Connector output | |
| G | straight |
| W | elbow 90 ° |
| 5. Shielding | |
| A | shielded |

Round plug connector 4 / 5-pin



- 1 → brown
- 2 → white
- 3 → blue
- 4 → black
- 5 → grey

Ordering code

Self-assembly

1. 2.

KB

| | |
|----------------------------|------------|
| 1. Number of pins | |
| 04 | 4-pin |
| 05 | 5-pin |
| 2. Connector output | |
| G | straight |
| W | elbow 90 ° |

Packaged

1. 2. 3. 4. 5. 6.

PU -

| | |
|----------------------------|-----------------------------------|
| 1. Number of pins | |
| K | 4-pin |
| K05 | 5-pin |
| 2. Cable material | |
| PU | PUR |
| 3. Cable length | |
| 02 | 2 m |
| 05 | 5 m |
| 10 | 10 m |
| 4. Shielding | |
| N | shielding not applied to coupling |
| S | shielding applied to coupling |
| 5. Connector output | |
| G | straight |
| W | elbow 90 ° |
| 6. Shielding | |
| A | shielded |

Round plug connector 5-pin



- 1 → brown
- 2 → white
- 3 → blue
- 4 → black
- 5 → grey

Ordering code

Self-assembly

1.

KB05

| 1. Connector output | |
|---------------------|------------|
| G | straight |
| W | elbow 90 ° |

Packaged

1. 2. 3. 4. 5.

K05 PU -

| | |
|----------------------------|-----------------------------------|
| 1. Cable material | |
| PU | PUR |
| 2. Cable length | |
| 02 | 2 m |
| 05 | 5 m |
| 10 | 10 m |
| 3. Shielding | |
| N | shielding not applied to coupling |
| S | shielding applied to coupling |
| 4. Connector output | |
| G | straight |
| W | elbow 90 ° |
| 5. Shielding | |
| A | shielded |

Clamping ring screw connection



| Type | Outside thread | Clamp. ring-Ø | Clamping ring |
|-------|----------------|-----------------|-----------------|
| GKV1 | M8 x 1 | 1.5 mm | Teflon |
| GKV2 | | | stainless steel |
| GKV3 | | 3.0 mm | Teflon |
| GKV4 | | | stainless steel |
| GKV5 | G ¼ | 1.5 mm | Teflon |
| GKV6 | | | stainless steel |
| GKV7 | | 3.0 mm | Teflon |
| GKV8 | | | stainless steel |
| GKV11 | 6.0 mm | Teflon | |
| GKV12 | | stainless steel | |
| GKV9 | G ½ | 6.0 mm | Teflon |
| GKV10 | | | stainless steel |
| GKV13 | | 8.0 mm | Teflon |
| GKV14 | | | stainless steel |
| GKV15 | 14.0 mm | Teflon | |

Flat-pin connector, thermoelectric-voltage free

For ambient temperatures up to 200°C

| Type | Thermocouple | |
|---|--------------|--|
| NST 1200 | type K | |
| NST 1700 | type S | |
| NKU 1200 O | type K | |
| U-coupling for installation in front panels | | |
| NKU 1200 | type K | |
| NKU 1700 | type S | |

For higher temperatures use ceramic plugs and coupling (upon request).

Immersion sleeve

EST01

Immersion sleeve for all probes without thread
Standard: G ½, FL = 100 mm, outside-Ø = 6 mm:
for probes with 5 mm Ø

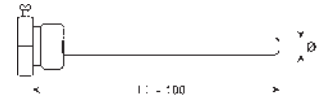

EST02

Immersion sleeve for all probes with G ½-thread
Standard: G ½ (internal/external), FL = 100 mm, outside-Ø = 8 mm:
for probes with 6 mm Ø

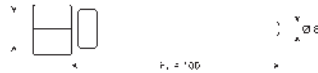

EST - 1. - 2. - 3. - 4.

| 1. Design type | |
|---------------------|---|
| 01 | for all probes without thread |
| 02 | for all probes with G ½-thread |
| 2. Thread | |
| 00 | standard G ½ |
| xx | desired thread upon request |
| 3. Probe length | |
| 00 | standard, FL=100 mm |
| xxx | desired length upon request |
| 4. Outside diameter | |
| 00 | standard Ø = 6 mm (design type 01)
standard Ø = 8 mm (design type 02) |
| xx | desired diameter upon request |

Heat conducting paste

GWL10G

Heat-conductive paste
for optimized heat transfer, 10 g in plastic syringe

Product information Flow - Temperature

Converter / Counter

Panel meter OMNI-TA



External converter with the same data as the electronics; can be mounted directly on the primary sensor, but as an external panel-mounting variant with IP 67 housing.

Panel counter OMNI-C-TA



External counter with the same data as the electronics; can be mounted directly on the primary sensor, but as an external panel-mounting variant with IP 67 housing.

OMNI - Tropical model



This OMNI electronic option should be used where temperatures change quickly, or for external installations (the device is filled with oil, and thus prevents condensate formation in the electronics housing, even under adverse circumstances)

OMNI - Remote



Function is identical to OMNI-suburb. Connection to the sensor is, however, made by wire, and so the measurement point and display location can be apart

Counter OMNI-C-FIS



Universal counter directly on the base device. Automatic conversion of the unit (ml, litre, m³) therefore only four digits are sufficient!

Your direct contact to us



+49 2191 9672-0



info@ghm-group.de



Headquarters

GHM Messtechnik GmbH
GHM GROUP CORPORATE
Tenter Weg 2-8
42897 Remscheid | GERMANY
Phone +49 2191 9672-0
Fax +49 2191 9672-40
info@ghm-group.de
www.ghm-group.de

Center of Competence

GHM Messtechnik GmbH
GHM GROUP – Greisinger
Hans-Sachs-Straße 26
93128 Regensburg | GERMANY
Phone +49 9402 9383-52
Fax +49 9402 9383-33
info@greisinger.de
www.greisinger.de

GHM Messtechnik GmbH
GHM GROUP – Honsberg
Tenter Weg 2-8
42897 Remscheid | GERMANY
Phone +49 2191 9672-0
Fax +49 2191 9672-40
info@ghm-group.de
www.ghm-group.de

GHM Messtechnik GmbH
GHM GROUP – Martens
Kiebitzhörn 18
22885 Barsbüttel | GERMANY
Phone +49 40 67073-0
Fax +49 40 67073-288
info@ghm-group.de
www.ghm-group.de

GHM Messtechnik GmbH
GHM GROUP – Imtron
Carl-Benz-Straße 11
88696 Owingen | GERMANY
Phone +49 7551 9290-0
Fax +49 7551 9290-90
info@ghm-group.de
www.ghm-group.de

Delta OHM S.r.l. a socio unico
GHM GROUP – Delta OHM
Via Marconi 5
35030 Caselle di Selvazzano
Padova (PD) | ITALY
Phone +39 049 8977150
info@deltaohm.com
www.deltaohm.com

Valco srl
GHM GROUP – Val.co
Via Rovereto 9/11
20014 S. Ilario di Nerviano
Milano (MI) | ITALY
Phone +39 0331 53 59 20
valco@valco.it
www.valco.it

GHM GROUP International

Austria

GHM Messtechnik GmbH
Office Austria
Breitenseer Str. 76/1/36
1140 Vienna | AUSTRIA
Phone +43 660 7335603
a.froestl@ghm-messtechnik.de
www.ghm-group.de

Brazil & Latin America

GHM Messtechnik Do Brasil Ltda
Av. José de Souza Campos,
1073, cj 06 | Campinas, SP
13025 320 | BRAZIL
Phone +55 19 98275 0069
info@grupoghm.com.br

Czech Republic / Slovakia

GHM Greisinger s.r.o.
Ovci hajek 2 / 2153
158 00 Prague 5
Nové Butovice | CZECH REPUBLIC
Phone +420 251 613828
Fax +420 251 612607
info@greisinger.cz
www.greisinger.cz

Denmark

GHM Maaleteknik ApS
Maarslet Byvej 2
8320 Maarslet | DENMARK
Phone +45 646492-00
Fax +45 646492-01
info@ghm.dk
www.ghm.dk

France

GHM GROUP France SAS
Parc des Pivollez
9 Rue de Catalogne
69150 Décines (Lyon) | FRANCE
Phone +33 6 60 32 06 35
contact@ghm-group.fr
www.ghm-group.fr

India

GHM Messtechnik India Pvt Ltd.
209 | Udyog Bhavan
Sonowala Road | Gregaon (E)
Mumbai - 400 063 | INDIA
Phone +91 22 40236235
info@ghmgroup.in
www.ghmgroup.in

Italy

Sales Greisinger & Delta OHM
GHM GROUP – Delta OHM
Via Marconi 5
35030 Caselle di Selvazzano
Padova (PD) | ITALY
Phone +39 049 8977150
info@deltaohm.com

Italy

Sales Honsberg, Martens, Val.co
GHM GROUP – Val.co
Via Rovereto 9/11
20014 S. Ilario di Nerviano
Milano (MI) | ITALY
Phone +39 0331 53 59 20
alessandro.perego@valco.it

Netherlands

GHM Meettechnik BV
Zeeltweg 30
3755 KA Eemnes
NETHERLANDS
Phone +31 35 53805-40
Fax +31 35 53805-41
info@ghm-nl.com
www.ghm-nl.com

South Africa

GHM Messtechnik SA (Pty) Ltd
16 Olivier Street
Verwoerdpark, Alberton 1453
SOUTH AFRICA
Phone +27 74 4590040
j.grobler@ghm-sa.co.za



Visit us: www.ghm-group.de