





# Table of Contents

<b>1</b>	<b>General Information</b>	<b>7</b>
1.1	Validity of these Instructions	7
1.2	How to Use These Instructions	8
1.2.1	Purpose	8
1.2.2	Conventions	8
1.2.3	Correcting Faults	8
1.3	Purpose	9
1.3.1	Purpose	9
1.3.2	Purpose Internal Firing Rate Controller	10
1.3.3	Purpose of Internal O <sub>2</sub> Trim	10
<b>2</b>	<b>For Your Safety</b>	<b>11</b>
<b>3</b>	<b>Operation</b>	<b>12</b>
3.1	Digital Inputs	12
3.2	Operating Description	12
3.3	Range Limits	13
3.4	Internal Firing Rate	13
3.5	Manual Mode	13
3.6	Parameter Settings	13
3.7	Correction	13
3.8	Flying Curve Change	14
3.9	Integrated Power Control Unit	14
3.10	4 or 8 Curve Sets	14
3.11	Direct Connection to R. P. M. Sensor	14
3.12	Fail-Safe Feedback	14
3.13	Pre-purge Limit	15
3.14	Energy-saving Mode for Scrolling Text Display	15
3.15	Separate Ignition Point	15
3.16	Integrated O <sub>2</sub> Trim	15
<b>4</b>	<b>Settings</b>	<b>16</b>
4.1	Inputs	16
4.1.1	Significance of ID Number	16
4.1.2	Inputs	16
4.1.3	Configuration Sticker	16
4.1.4	Configuration Number	17
4.2	Conditions On Delivery	18
4.2.1	Assignment of Sockets in Inputs	18
4.2.2	Configuration Cards (Examples)	19
4.2.3	Processor Card	19
4.2.4	Power Supply Card	20
4.2.5	Plug-in P.C.Card for Continuous Output	20
4.3	Parameter	21
4.3.1	Parameter Settings	21
4.3.2	Access Levels	21
4.3.3	Password Entry	22
4.3.4	How to Change the Password	22
4.3.5	Changing Parameters	23

# Table of Contents

<b>5</b>	<b>Firing Rate Controller (optional)</b> . . . . .	<b>24</b>
5.1	Operation . . . . .	24
5.1.1	Enter Setpoint of Firing Rate Controller . . . . .	24
5.1.2	Operating Description . . . . .	24
5.1.3	Control by Atmospheric Condition . . . . .	25
5.1.4	Setpoint Changeover . . . . .	25
5.1.5	Start-up Sequence . . . . .	26
5.1.6	Thermostat and Control Range . . . . .	27
5.1.7	Manual Control . . . . .	28
5.2	Control Setting . . . . .	28
5.2.1	Meaning of the Display . . . . .	28
5.2.2	How to Adjust the Burner Firing Rate Controller . . . . .	28
5.2.3	Control Range . . . . .	29
5.3	Control Mode . . . . .	29
<b>6</b>	<b>Commissioning</b> . . . . .	<b>32</b>
6.1	Before Commissioning . . . . .	32
6.1.1	Setting the Limit Switches of the Motors . . . . .	32
6.2	Function Test . . . . .	32
6.3	Significance of Digital Display . . . . .	33
6.4	Adjusting Control Elements . . . . .	34
6.4.1	Operation Of Control Elements For Potentiometer Adjustment - Limit Switch Settings . . . . .	34
6.5	Programming of Curves . . . . .	35
6.5.1	Programming of Fuel/Air Ratio Control . . . . .	35
6.5.2	Entirely New Curve - Clear Memory . . . . .	36
6.5.3	Programming 1 <sup>st</sup> Point (Separate Ignition Point) . . . . .	36
6.5.4	Programming While The Burner Is Running . . . . .	37
6.5.5	Programming While The Burner Is Stationary . . . . .	38
6.5.6	Programming 2 <sup>nd</sup> to 20 <sup>th</sup> Point . . . . .	39
6.5.7	Programming Last Top Point . . . . .	40
6.5.8	Saving Curve . . . . .	40
6.5.9	Check Monitoring Values . . . . .	41
6.5.10	Adding Points . . . . .	42
6.5.11	Change Curve Point . . . . .	43
6.6	O <sub>2</sub> Trim . . . . .	44
6.6.1	Automatic Function Monitoring During Operation . . . . .	44
6.6.1.1	Adjusted The Integrated O <sub>2</sub> Controller (Optional) . . . . .	44
6.6.1.2	Test During Burner Start . . . . .	44
6.6.1.3	O <sub>2</sub> Monitoring Band . . . . .	44
6.6.1.4	O <sub>2</sub> Limit Curve . . . . .	45
6.6.1.5	Dynamic Probe Test . . . . .	46
6.6.1.6	Probe Blockage . . . . .	46
6.6.1.7	Correction Output Monitoring . . . . .	47
6.6.2	Control Strategy . . . . .	48
6.6.2.1	With Pre-setting For Firing Rate Changes . . . . .	48
6.6.2.2	Extended Control Strategy (Air Shortage) . . . . .	49
6.6.3	Connecting the O <sub>2</sub> Measurement Device . . . . .	50
6.6.3.1	Via Analogue Interface . . . . .	50

## Table of Contents

6.6.4	Operating Control and Displays	51
6.6.4.1	Mode Switching	51
6.6.4.2	Calling up O <sub>2</sub> Trim Text Messages	52
6.6.5	Commissioning	53
6.6.5.1	Correction Output Monitoring	53
6.6.5.2	Enter the O <sub>2</sub> setpoint curve	53
6.6.5.3	Changing the O <sub>2</sub> setpoint curve	55
6.6.5.4	Calling up the Set Correction Mode	55
6.6.5.5	Calculation Of Control Parameters	55
6.6.5.6	Lag time (Parameters 898 / 900)	56
6.6.5.7	P-factor (Parameter 899)	56
6.6.5.8	Setting a Base Value for "Deactivated controller" and "Air shortage"	57
6.6.5.9	Base Value For Inactive O <sub>2</sub> Trim/Insufficient Air	57
6.6.5.10	What Additional Modes mean	58
6.6.5.11	How to Reset od	59
6.6.5.12	Calling up O <sub>2</sub> Trim Text Messages	59
6.7	Correction	60
6.7.1	Set Correction Input	60
6.7.2	CorrectionType1	60
6.7.3	Correction Type 2	63
6.7.4	Correctional Range	64
6.7.4.1	Correction Range Settings	64
6.7.4.2	Calling up the Set Correction Mode	64
6.7.4.3	Edit Correction Range	64
6.7.5	Correction Modes	66
6.8	Shut-off Limits	67
6.8.1	Run to Shut-off Limits	67
6.8.2	Check Shut-Off Limits on TPS Output of VMS	68
6.8.3	Check Shut-Off Limits on VMS Continuous Output	69
6.8.4	Checking O <sub>2</sub> Influence	70
6.8.5	Tolerance Limit in Direction Air Deficiency	71
6.8.6	Protocol Example	72
<b>7</b>	<b>Tips and Tricks</b>	<b>73</b>
7.1	Programming 1st Point (Ignition Firing Rate Point)	73
7.2	Programming While The Burner Is Running	74
7.3	Programming While The Burner Is Stationary	75
7.4	Reversing the Programming	75
7.5	Commissioning Equipments	75
7.6	Adjusting Firing Rate Individually	76
7.7	Entering an Initial Curve	76
7.8	Approaching Control Elements From One Side	76
7.9	Enter Set Point Values	77
7.10	Entering the Highest Setpoint	77
7.11	Start Without Pre-Purge	77
7.12	Ignition Delay During Adjustment	77
7.13	Set Firing Rate Automatically	77
7.14	Entering the Fuel/Air Ratio Control With The Burner Stationary	78
7.15	Recirculation Damper Closed During Pre-purge	78
7.16	Switching the Burner On Again Through the Setpoint	78

# Table of Contents

<b>8</b>	<b>System Operation</b>	<b>79</b>
8.1	Mode Display	79
8.1.1	Mode Abbreviations Used	79
8.1.2	O <sub>2</sub> Trim Modes	80
8.1.3	ES Mode (Set - Control)	80
8.1.4	Proceed with Programming	81
8.2	Check Sums - Hours of Operation	82
8.2.1	Calling the Checksums	82
8.2.2	Calling up the Hour Counter	83
8.3	Messages / Faults	84
8.3.1	What Happens if There is a Fault?	84
8.3.2	Reading Faults	84
8.3.3	Resetting Faults	84
8.3.4	Recalling Fault History	85
8.3.5	What Happens if a Fault Occurs in the O <sub>2</sub> Controller?	85
8.3.6	Air Deficiency Failure	86
8.3.7	Resetting O <sub>2</sub> Errors	86
8.3.8	Calling Fault History O <sub>2</sub> trim	86
8.3.9	Fault Codes	87
<b>9</b>	<b>Maintenance</b>	<b>109</b>
9.1	Changing EPROMs	109
9.1.1	Replacing a Data EEPROM	109
9.1.2	Re-enter Range Limits	110
9.2	Installing a New Software Version	110
9.2.1	Procedures for New Software Installation	110
<b>10</b>	<b>Appendix</b>	<b>111</b>
10.1	Wiring According to EMC	111
10.1.1	Shields Connection	111
10.1.2	PE Busbar	111
10.1.3	Control Cabinet Wiring	111
10.1.4	Shielding Cables from the Field	112
10.2	Feedback at Three-Point-Step Channels	112
10.2.1	Connect with Positive Locking	112
10.2.2	Fail-Safe Feedback	112
10.3	External Switching of the Fuel Motors/ Valves	114
10.4	Changing Control Drives / Potentiometers	115
10.4.1	How to replace a motor with LAMTEC pre-calibration	115
10.4.2	How to Replace a Complete Control Drive	116
10.4.3	How to Replace a Potentiometer	116
10.5	Schalter und Tastenkombination der Bedieneinheit	116
10.5.1	Front Panel VMS/FMS	116
10.5.2	O <sub>2</sub> Trim	119
10.6	Process Sequence Charts	120
10.7	Wiring of the Analogue Inputs	122
10.8	Connecting Diagrams	123
10.9	R. P. M. Sensor	129
10.9.1	Direct Connection to R. P. M. Sensor	129

## Table of Contents

10.9.2 Selection of a Suitable R. P. M. Sensor .....	131
10.10 Connection Diagram Relay Modules .....	133
10.11 Modem Connection Plan for Remote Access .....	134
10.12 Technical Data .....	136
10.13 Accessories and Spare Parts .....	138
10.14 Declaration of Conformity .....	140
10.15 Protocol Example .....	142
10.16 O <sub>2</sub> Setpoint Curves .....	143

# 1 General Information

## 1 General Information

### 1.1 Validity of these Instructions

---

This instructions apply to the Fuel/Air Ratio Control System VMS 4 and VMS 5 in any configuration.

The software-related information relates to software version v5.8. The software version can be found on the label of the programme EPROM. In case of doubt ask the LAMTEC Service - phone: +49 (0)6227 6052-33 or email: support @lamtec.de

If you use another software version as the version mentioned above, some of the described functions may not be available or some function which are available with your software version may not be described in this manual.

The units conform to the following standards and regulations:

VMS:    EN 298 (checked against this)  
          EN 230 (checked against this)  
          TRD 411  
          TRD 412  
          TRD 604  
          EMC Directive  
          Low Voltage Directive  
          Gas Appliance Directive

TÜV test symbol: TÜ 12 / 97 01 74  
                          CE-0085 AS 0254

# 1 General Information

## 1.2 How to Use These Instructions

### 1.2.1 Purpose

This manual consists of all necessary information for its designated use.

Additional information such as configuration examples, application possibilities, software settings, etc can be found in separate publications.

Special information which involves optional components for this device are described in a separate print.

### 1.2.2 Conventions

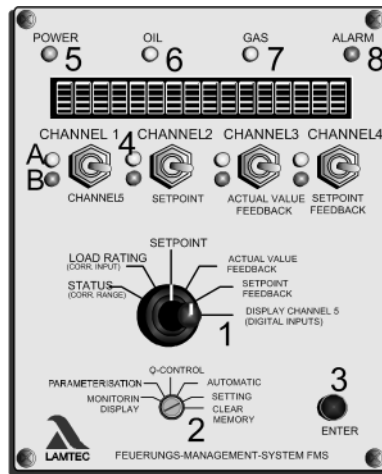

The figures and letters in brackets (1), (2), (3), (4), (5), (6), (7), (8), (A) and (B) relate directly to the picture of the front panel. They identify the part on which the specified action is to be performed or on which a reaction can be seen.

The lines below the procedural instruction describe the reaction of the system or unit following the operation.

If you now follow the operations step by step, paying attention to the instructions, you will automatically be working correctly. If any of the operations indicated do not occur, there is a fault with the unit or the system. You should correct the fault first before proceeding.

### 1.2.3 Correcting Faults

Information regarding localisation of errors and its remedies as well as a list of fault codes, fault text and help can be found in chapter 8.1.4 *Proceed with Programming*

This chapter, makes no claim as to the completeness of the information. If the actions described do not lead to the desired result, the unit or parts of the unit (e.g. front panel etc.) must be changed. If the fault still occurs, it is probably a plant-specific fault.

#### NOTICE

You can download the up-to-date version of these instructions from <http://www.lamtec.de> as a PDF File.

You will find the version number at the backside of this document:

For example:

DLT 1015-08-aEN-017

DLT 1015 = document number

aEN = print version and language (EN for English)

017 = version number

# 1 General Information

## 1.3 Purpose

### 1.3.1 Purpose

---

#### **Intended purpose VMS 4/VMS 5**

The VMS 4 as well as VMS 5 is a control unit for combustion system.

#### **Brief description**

The VMS 4 adjusts up to four control elements as a function of a control variable (generally the burner firing rate) according to freely programmable curves.

The VMS 5 adjusts up to 5 control elements as a function of a control variable according to freely programmable curves.

2 sets of curves (e.g. for oil or gas) can be filled as standard, with the option for 4 or 8 sets of curves.

Examples of possible control elements:

- Combustion air damper
- Combustion air fan
- Fuel quantity
- Atomiser steam
- Re-circulation fan
- Flue gas damper
- Flue gas fan

Up to 20 points can be programmed for each channel. The display is relative between 0 and 999.

The VMS has two correction inputs for shifting the setting curves, allowing a feedback control (e.g. O<sub>2</sub> trim unit) to be connected up.

Each output is freely configurable, either three-point step control element output for direct actuation of a motor or constant output (on the VMS 5 the 5th channel is always constant). The constant output can be set to any of the following variables:

- Current signal 0 ...20 mA
- Current signal 4 ...20 mA
- Voltage signal 0 ...10 V

The VMS 4 has two correction inputs for shifting the setting curves, allowing a feedback control (e.g. O<sub>2</sub> trim unit) to be connected up.

The VMS has one serial interface for remote control/ display via PC (Windows software available separately) and for connection to other system components via BUS (e.g. fault message system, O<sub>2</sub> trim). Connections for Interbus-S, PROFIBUS, Modbus and CANopen are available as options. Other BUS systems on request.

The VMS constantly monitors its own functioning and that of the control elements connected.

Each analog output (control variable and feedback or correction) is freely configurable via plug-in cards.

Alternatively:

- Potentiometer (1 - 5k $\Omega$ )
- Step input (DPS)
- Current signal 0/4...20 mA
- Namur transmitter
- PT100

# 1 General Information

The operating states are predefined in the VMS through potential-free contacts

- Burner on
- Control enabling
- Pre-purge
- Recirculation enabling
- Flame signal
- Fuel selection

The unit is of error-proof construction.

## 1.3.2 Purpose Internal Firing Rate Controller

---

This software option enables the calculating of the burner's required firing rate setting continuously for a specified setpoint value (referred e.g. to temperature or pressure), through comparison with the actual value. This firing rate setting can be notified internally to the electronic fuel/air ratio control as the specified value.

## 1.3.3 Purpose of Internal O<sub>2</sub> Trim

---

This software function makes it possible to regulate one or several actuators independently of a switched-on O<sub>2</sub> actual value. By using a self-optimising controller strategy, it is also possible to regulate burners with frequent firing rate changes.

## 2 For Your Safety

The following symbols are used in this document to draw the user's attention to important safety information. They are located at points where the information is required. It is essential that the safety information is observed and followed, and that applies particularly to the warnings.

### **DANGER!**

This draws the user's attention to imminent danger. If it is not avoided, it will result in death or very serious injury. The plant including its surroundings could be damaged.

---

### **WARNING!**

This draws the user's attention to the possibility of imminent danger. If it is not avoided, it may result in death or very serious injury. The plant including its surroundings could be damaged.

---

### **CAUTION!**

This draws the user's attention to the possibility of imminent danger. If it is not avoided, it may result in minor injuries. The plant including its surroundings could be damaged.

---

### **NOTICE**

This draws the user's attention to important additional information about the system or system components and offers further tips.

---

The safety information described above is incorporated into the instructions.

Thus, the operator is requested to:

- 1 Comply with the accident prevention regulations whenever work is being carried out.
- 2 Do everything possible within his control to prevent personal injury and damage to property.

### 3 Operation

#### 3.1 Digital Inputs

---

Digital inputs VMS

For the VMS to work in accordance with the requirements of the combustion plant, the status signal of the plant must be reported to the VMS.

These are:

- Burner start-up
- Control release
- Pre-purge signal
- Recirculation release
- Flame signal
- Fuel specification

For application of burner control, the VMS produces 3 messages via relay:

- Fault
- Ignition position
- All channels on highest value (high settings)

#### 3.2 Operating Description

---

(For example chart, see Appendix)



#### **WARNING!**

The operating sequence described relates to a usual configuration of the unit. Depending on how the parameter of the device is configured, this can result in a somewhat different (see appendix) sequence.

---

A signal is first sent to terminal 2 (burner ON), indicating when the burner has to start. The display mode changes from "AU"(off) to "BE"(ready). The flue gas damper goes to "OPEN" mode. This is followed by the pre-purge signal (terminal 3). Continuous output runs on the highest programmed point. Three-step-point outputs receive a continuous "OPEN" signal and run to the limit switches.

The mode display changes to "VO" (pre-purge). The recirculation channels go to open only when a signal is applied to terminal 6 and the assigned channel, generally the air valve, is 75% open. If there is to be no separate recirculation valve delay, a continuous signal can be applied to terminal 6. The recirculation valve delay is then automatic. Once all active channels have reached their uppermost point, the high firing rate relay picks up. The fuel channel is then already going to the ignition position.

During pre-purge, the VMS checks the "CLOSED" and "OPEN" positions of each actuator. On completion of the pre-purge period (removal of the signal from terminal 3), the air and recirculation channels will close (air to the ignition point and recirculation fully closed). The mode display changes to "CLOSED". The ignition-position relay then picks up. The flue-gas valve remains open, or the flue-gas fan remains on top rotational speed.

Following completion of ignition, a signal is applied to terminal 8 (flame signal). The flue-gas channel goes to the programmed point. The firing rate displayed continues to be the firing rate at the ignition firing rate point. The mode display changes to "GL" (base firing rate). A signal to terminal 6 then prompts the recirculation channel to go to the programmed point.

## 3 Operation

Correction is active. The controller remains in the base firing rate position until a control enabling signal (terminal 4) is given. Once control is released, the VMS tracks the externally applied firing rate. A current signal proportional to the position of the fuel/air ratio control is emitted as internal firing rate (not on VMS 5). The mode display goes out.

### 3.3 Range Limits

---

In the 1<sup>st</sup> pre-purge after 'Clear memory', the VMS determines the maximum range of travel for each control element and stores this automatically. If no ranges limits have yet been determined, the setting (in the case of constant outputs the feedback setting) in pre-purge stands at 0 and 999 points respectively. At all further starts a check is made to see that these range limits are correct. Should the limit switches be shifted or the frequency converter setting changed after programming, the range limits must be re-entered.

If the range limits cannot be determined automatically, they can also be entered manually by using parameters. If the VMS has no existing range limits, it automatically takes the top and bottom point of the curve as the limit. It then does not go beyond this.

### 3.4 Internal Firing Rate

---

The internal firing rate is the firing rate value at which the fuel/air ratio control currently stands. It therefore corresponds indirectly to the output of the burner.

The internal firing rate is displayed in addition to the external firing rate signal.

In the 'firing rate value' position therefore both the external firing rate (left-hand) and the internal firing rate (right-hand) are displayed.

The value of the internal firing rate can be outputted via the monitor output, in order to connect further units (e.g. O<sub>2</sub> trim, only on VMS 4). When connecting other units, it must be remembered that the signal in itself is not error-proof.

### 3.5 Manual Mode

---

When switching over to 'firing rate value' with the burner running the burner firing rate can be set by the VMS. The firing rate value can then be adjusted with the channel 1 toggle switch.

The system follows this firing rate value in the fuel/air ratio control.

Operating a switch other than channel 1 causes the unit to exit manual mode again.

### 3.6 Parameter Settings

---

The person commissioning the unit can adjust various functions of the VMS by using parameters (e.g. post-purge time). The parameters are classified into various safety levels. With the exception of the lowest safety level these are accessible only with a password. The parameter settings can be undertaken both on the unit itself and by using a PC and Windows software.

### 3.7 Correction

---

The VMS has 2 correction inputs. An analog signal (0/4 ... 20 mA) can be connected to these for shifting the set curves (e.g. for O<sub>2</sub> correction or air temperature correction). The assignment of the correction to the individual output channels and the mode of operation can be adjusted by parameters.

## 3 Operation

### 3.8 Flying Curve Change

---

If the select signal for the curve sets is changed whilst in operation, the VMS goes to fault 351. With this option, however, it allows changing from one curve set to another. The settings change abruptly. The band monitorings are replaced for a period of 30 seconds by running direction monitoring. After 30 seconds the control elements must have reached their new value.

### 3.9 Integrated Power Control Unit

---

An integrated power control unit is also available as an option. Where this (option) is used the actual temperature or the actual pressure is directly switched instead of the firing rate signal. The control parameters are adjusted via parameters. It is also possible to change the setting (daytime/night time operation) and to control the atmospheric conditions by switching in the outside temperature.

The integral output controller is a PID controller with special combustion technology functions. It can be used as a fixed-value controller or as a weather-dependent controller. The following signals can be set:

- Actual value (analogue)
- External temperature or some other analogue signal for target value shifting (only in weather-dependent controllers)
- Target value switching (via zero-potential contact)

Combustion enabling by the output controller takes place internally in the VMS

Boundary values that switch the burner on and off, need to be set via parameter setting. In this case, the startup signal is removed internally from VMS via the output controller module. The operator is alerted by the display (running text) that the output controller refuses to enable a startup.

### 3.10 4 or 8 Curve Sets

---

The VMS has 2 curve sets as standard. 4 or 8 curve sets may be used, as an option.

### 3.11 Direct Connection to R. P. M. Sensor

---

An output for controlling the speed of a combustion air fan or a re-circulation fan etc. can be monitored by switching the pulse output of a Namur transmitter directly to the VMS.

### 3.12 Fail-Safe Feedback

---

Continuous outputs and three-point step outputs have different feedback requirements.

In the case of continuous outputs comparisons are made between output and feedback values in or to check the plausibility. The units therefore do not have to be intrinsically error-free in order to form the feedback signal. For availability reasons (minimisation of interference) the reproducibility of the values should be as good as possible.

For technical reasons this method cannot be used in the case of three-point step outputs. For this reason TÜV approved potentiometers must be connected directly as feedback to the VMS. These potentiometers must positively render the position of the damper.

## 3 Operation

### 3.13 Pre-purge Limit

---

Normally during pre-purge each control element runs as far as it's uppermost stop. Now, by parameters, a limit can be set for each channel that is not exceeded during pre-purge.

### 3.14 Energy-saving Mode for Scrolling Text Display

---

The brightness of the display can be adjusted to the ambient light conditions by parameters. In addition the display can be set to automatically revert to the lowest brightness level if not operated within a given period of time.

### 3.15 Separate Ignition Point

---

In the standard version the ignition point is situated outside the accessible range in order to set a separate fuel/air ratio. By using parameters, however, the ignition point can be adjusted so that it lies on the fuel/air ratio control curve.

### 3.16 Integrated O<sub>2</sub> Trim

---

- optimises combustion system
- saves fuel
- minimises pollutants

The main purpose of O<sub>2</sub> trim is to compensate for combustion variables that affect combustion. In addition, the O<sub>2</sub> trim system monitors the combustion's fuel/air ratio. A message is output at once if it strays outside the permitted limits. The following are the main perturbing factors that affect combustion:

<b>Air:</b>	<b>Fuel:</b>	<b>System:</b>	<b>Mechanical systems:</b>
Temperature	Calorific value	Burner	Mechanical hysteresis
Pressure	Temperature	Boiler	(free play)
Humidity	Viscosity		
Calorific value	Density		
	Gas pressure fluctuations		

The O<sub>2</sub> trim unit is implemented as a free-standing software module. The unit compares the residual oxygen content in the exhaust gas of a combustion system measured by the LT1/LT2 Lambda transmitter (actual value) with the optimum residual oxygen content (target value). The target values are stored in the instrument in the form of an installation-specific curve. The control unit applies a correction until the actual value corresponds to the target.

The calculated output value of the O<sub>2</sub> trim module is transmitted to the fuel/air ratio control module as a correction input signal.

## 4 Settings

### 4 Settings

#### 4.1 Inputs

##### 4.1.1 Significance of ID Number

---

The ID number comprises of 8 characters, e.g. 664 V 0010.

The two figures before the letter denote the unit, in this case a VMS 4.

The letter denotes whether the unit is a VMS or a . The penultimate figure provides information on the unit hardware.

It also determines which connection diagram applies (see chapter *10.8 Connecting Diagrams*).

##### 4.1.2 Inputs

---

The inputs can be configured on the backplane by plug-in configuration cards. Any of the following can be connected up to each input:

- a potentiometer in range from 1 ... 5 k $\Omega$
- a current signal 0 ... 20 mA or 4 ... 20 mA
- a step signal (OPEN/CLOSE-commands)
- a frequency signal (Namur transmitter), for details see appendix
- a PT 100 element
- flame sensor module (in preparation)

There is a plug-in card for each configuration. This is inserted into the respective socket in order to configure the input.

##### 4.1.3 Configuration Sticker

---

The factory setting is entered on a sticker on the side of the unit. This corresponds either to the customer data or, if nothing was specified, the standard setting (see condition on delivery). The EEPROM checksums and thereby the software version are also entered on this sticker, together with the configuration number and hence the hardware setting.

## 4 Settings

### 4.1.4 Configuration Number

The configuration number is a 15-digit number, constructed according to a fixed code.

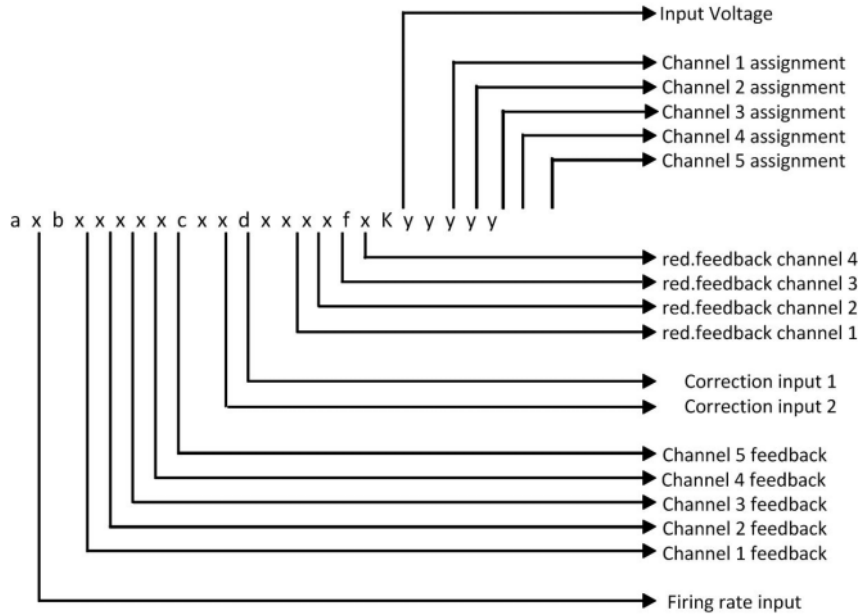

K = Channel assignment	f = Input voltage	a, b, or d = Feedback, correction and firing rate	C:
Y = 1 ⇔ Recirculation	X = 1 ⇔ 230 VAC	X = 1 ⇔ Potentiometer input 1kΩ...5 kΩ	0 = unoccupied
Y = 2 ⇔ Fuel	X = 2 ⇔ 115 VAC	X = 2 ⇔ continuous signal 0/4...20mA	2 = continuous signal 0/ 4...20mA
Y = 3 ⇔ Air	X = 3 ⇔ 24 ACV	X = 3 ⇔ TPS input	7 = mixed signal 4...20mA
Y = 4 ⇔ Flue gas	X = 5 ⇔ Special voltage	X = 4 ⇔ Impulseingang (Drehzahlmesser)	9 = O <sub>2</sub> actual value as 0/4...20mA
Y = 5 ⇔ mech. fuel/air ratio control		X = 5 ⇔ PT 100-input	
y = 6 ⇔ Steam		X = 6 ⇔ Flame sensor input (only on red. feedback channel 4)	
		X = 8 ⇔ continuous signal with 24 V supply for transducer	
		X = 0 ⇔ unoccupied	

## 4 Settings

### 4.2 Conditions On Delivery

All units are set according to the order. Settings not evident from the ID number or configuration number must be indicated separately.

In particular:

Outputs

- whether continuous or three-point step
- whether 0...10 V, 0/4 ... 20 mA
- position of the outputs in the event of fault

Inputs, Firing rate, Feedback

- whether potentiometer or 0/4 ... 20 mA or step
- whether inputs are used double (redundant) and if so, which (possible only if the integrated power control unit is not used)
- whether special plug-in configuration cards (Pt100, Namur transmitter) are used?

Correction input

- 0 ...20 or 4 ... 20 mA
- Mode of operation, on which channel, upward or downward shift (modifiable only via software)

#### 4.2.1 Assignment of Sockets in Inputs

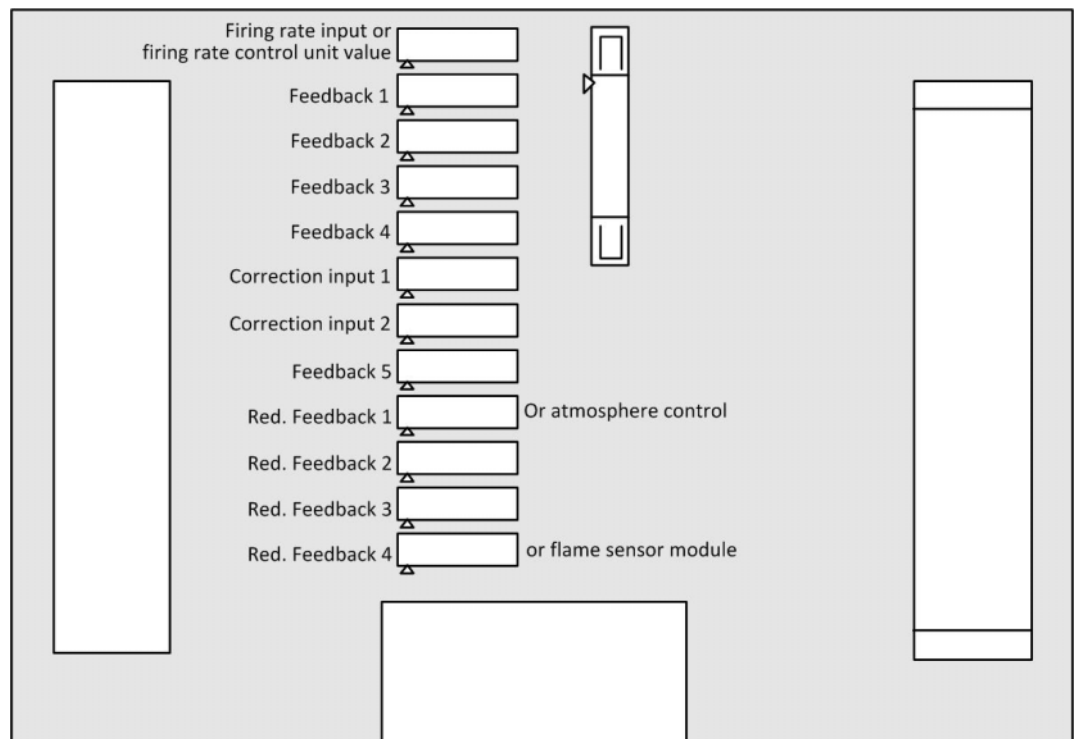

Fig. 4-1 Backplane: Assignment of sockets to inputs

## 4 Settings

### 4.2.2 Configuration Cards (Examples)

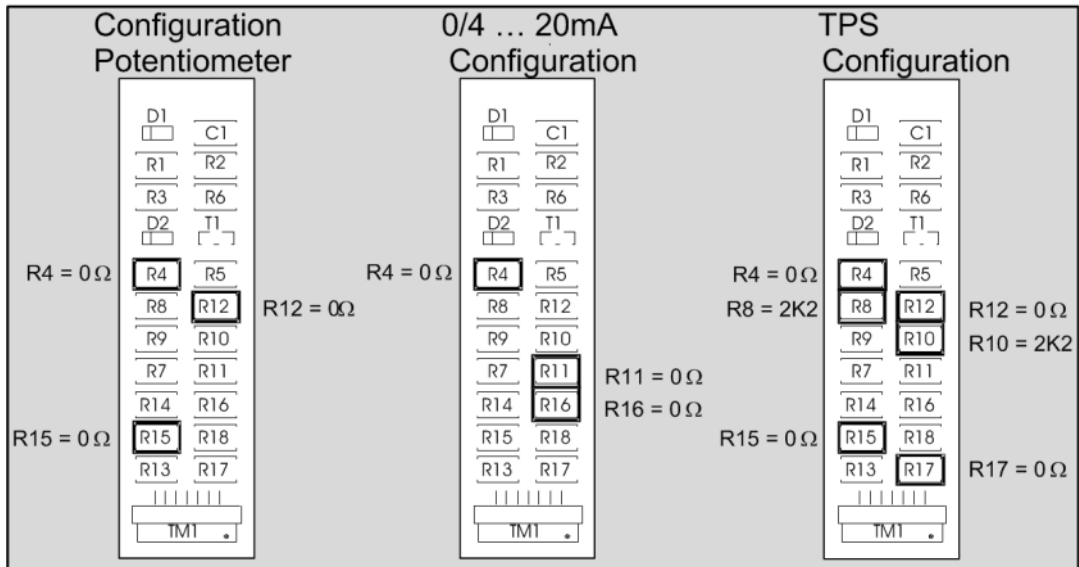

Fig. 4-2 Example: Configuration card

### 4.2.3 Processor Card

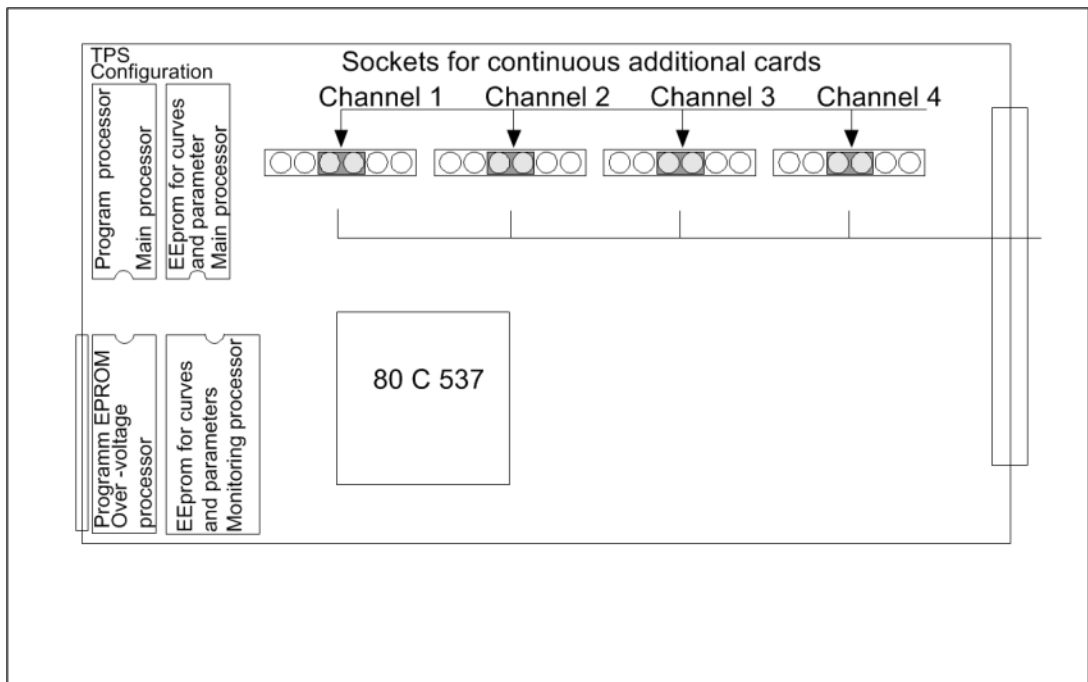

Fig. 4-3 Processor card

#### NOTICE

Continuous channels must have all be fitted with additional cards from channel 1 onwards

## 4 Settings

### 4.2.4 Power Supply Card

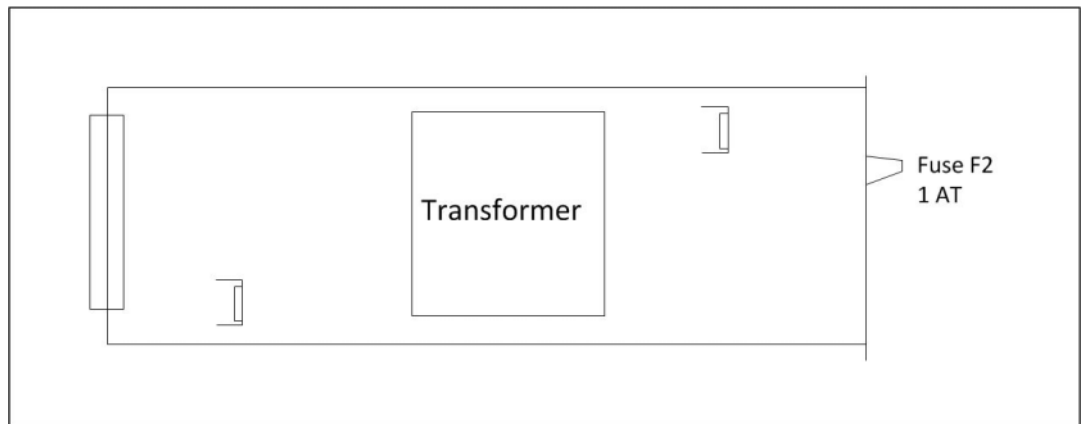

Fig. 4-4 Power supply card

### 4.2.5 Plug-in P.C.Card for Continuous Output

The standard control outputs are three-point step (except for a possible 5-channel. This is always continuous). Each TPS output can be reconfigured to make it continuous by plugging in an additional card.

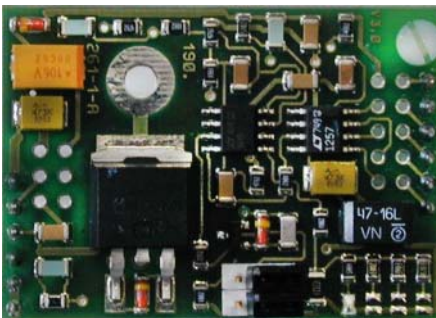

Fig. 4-5 Plug-in p.c. card for a continuous output

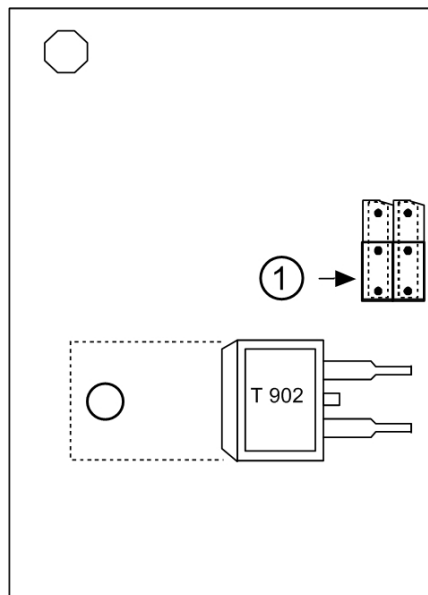

Fig. 4-6 1 = Bridge - voltage output  
0 ... 10V

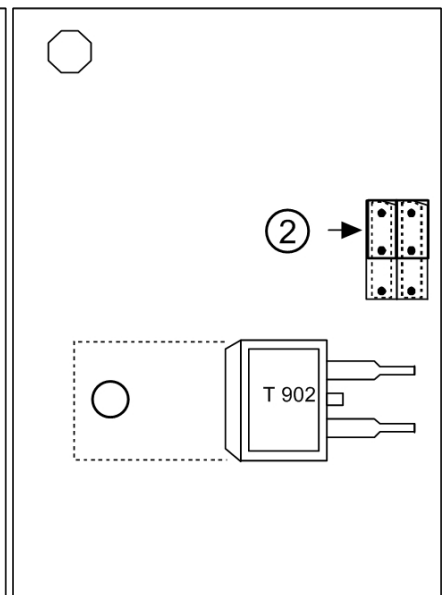

Fig. 4-7 2 = Bridge - current output  
0/4 ... 20 mA

The jumpers serve only for hardware switching between current output and voltage output. The selection of 0 or 4 ... 20 mA is done through the software by parameters.

## 4 Settings

### 4.3 Parameter

#### 4.3.1 Parameter Settings

---

The parameter level can be accessed by turning to the 'Parameter' selector switch position. When working on level 1 ... 4, this works only with the burner stationary (i.e. no signal on the digital inputs). Only level 0 is accessible with the burner running.

#### **NOTICE**

As a rule, the factory parameter settings are precisely tuned for the installation for which the unit has been designed. Therefore, it is only necessary to change parameter settings in exceptional cases.

---

#### 4.3.2 Access Levels

---

The parameters are divided into four different access levels according to function and safety classification:

- Operating level (Level 0)  
Accessible without password, non-critical parameters that may possibly have to be altered during operation.
- Customer level (Level 1)  
Accessible with modifiable password (on delivery set at '0000'), access to parameters, adjustment of which calls for technical knowledge, which are tailored to the system and which are not altered during operation.
- Service level (Level 2)  
Accessible with a fixed password, but only to personnel specially trained in parameterisation. Access to all parameters that are not fixed on the basis of standards and technical regulations.
- Production levels (Level 3 and 4)  
Access to all parameters (only possible through LAMTEC)

Each parameter level is protected by its own checksum. This checksum serves to show that no changes have been made.

## 4 Settings

### 4.3.3 Password Entry

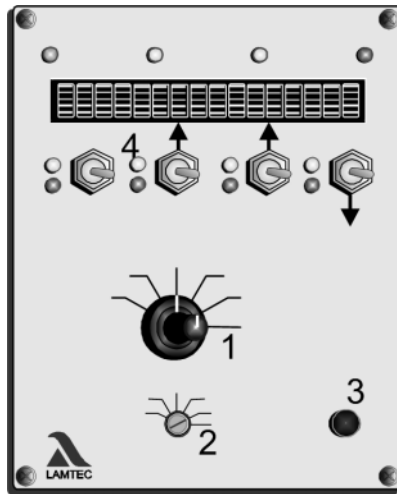

Switch (1) to STATUS

Push switch (4), channel 2 and 3, up and at the same time push channel 4 down  
→ the input field for the password appears on the display.

Set the appropriate password via the switch (4).

Select accept key (3)

Switch (2) to parameter setting

→ Parameters on the corresponding level are released

### 4.3.4 How to Change the Password

#### NOTICE

Only possible at customer level (Level 1) or higher.

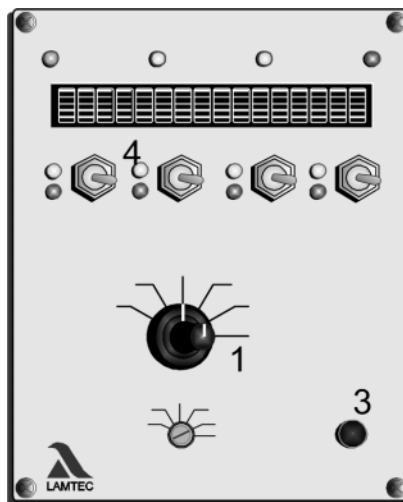

From access level 1 or higher:

Select switch (1) to STATUS

Simultaneously push keys (4) channel 2 and 3 upwards and channel 4 downwards

→ the display shows the password input field

Set the password level 1 through key (4)

Select switch (1) to DIGITAL INPUTS

Press the acceptance key (3)

→ new password is set

## 4 Settings

### 4.3.5 Changing Parameters

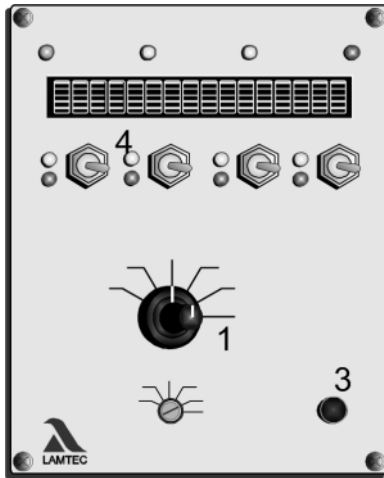

Select the required parameter with Channel 3 key

Change its value with Channel 4 key

-The values are accepted immediately without further confirmation

An explanatory text for the parameters can be called up by pressing the Enter key (3)

#### **NOTICE**

For larger values, changes can be in x100 steps with Channel 1 key and in x10 steps with Channel 2 key.

## 5 Firing Rate Controller (optional)

### 5 Firing Rate Controller (optional)

#### 5.1 Operation

##### 5.1.1 Enter Setpoint of Firing Rate Controller

Up to software version A3i1023, you can change the setpoint through parameter setting. From software version A3i1023 onwards, you can change the setpoint of the firing rate controller. This function works for running burner.

-display on firing rate rating

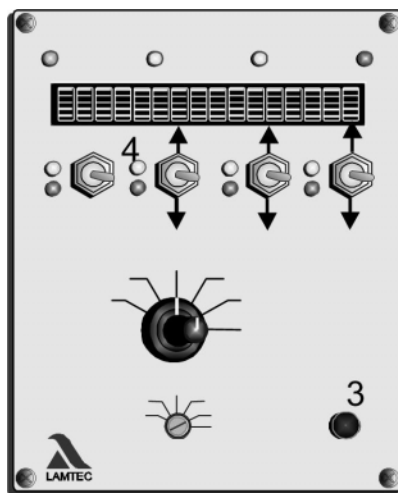

Switch (4) channel 3 downwards and channel 4 upwards simultaneously.

→ The display shows the entry field for setpoint.

You can change the setpoint through (4) channel 2.

With the ENTER key (3), you can save the new value.

Switch (4) channel 3 downwards and channel 4 upwards simultaneously

→ Leave the mode without saving the setpoint.

#### NOTICE

If you change the setpoint, the switchpoints will be shifted because they are defined as difference value to the setpoint.

#### NOTICE

Should the option 'Control by Atmospheric Conditions' be active, the setpoint cannot be changed and saved via the front plate. These setpoints can only be changed by the PC Remote Software (DLT1040) or with the GKI300 (DLT7106).

##### 5.1.2 Operating Description

The burner start-up is carried out as described above. At least 'Burner ON' signal and 'Release' must be sent by firing rate controller.

The burner starts as soon as it is receiving signals 'Burner ON' and 'Release' from firing rate controller. The firing rate controller is in operation not before the burner is running and the signal 'Control Release' is pending.

The default value of firing rate for fuel/air ratio control is set via integral firing rate controller. Depending on the difference between actual and setpoint value and adjusted control parameters this default firing rate value is set. When actual value is exceeding to maximum value the firing rate controller switches OFF combustion.

The firing rate controller is active in AUTOMATIC mode only.

## 5 Firing Rate Controller (optional)

### 5.1.3 Control by Atmospheric Condition

If the burner firing rate controller is configured as "controlled by atmospheric conditions" the setpoint value can be shifted between the parameterised setpoint minimum and setpoint maximum by connecting another PT 100 temperature sensor. When utilising control by atmospheric conditions, the outside temperature is a component of setpoint calculation. This allows the operator to enter a minimum and a maximum setpoint, between which the outside temperature can determine the final setpoint value.

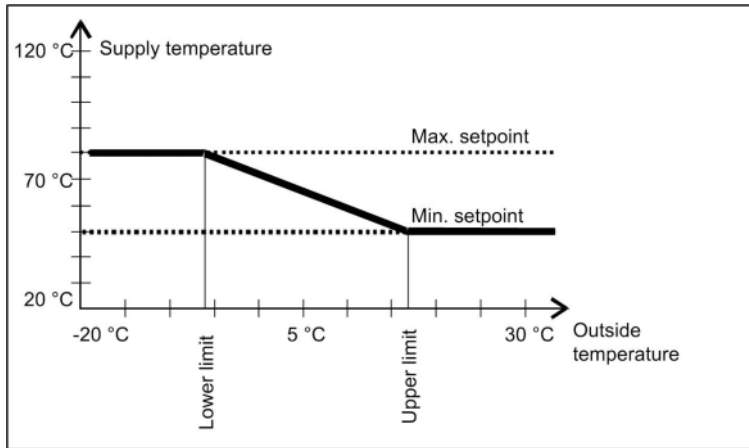

Fig. 5-1 Control by atmospheric conditions

### 5.1.4 Setpoint Changeover

You can switch the setpoint with the input "setpoint switchover". If you use a version with fixed setpoint value it is possible to select one of the two values, which are entered in the parameters 796 and 798 with this contact.

If you have activated the control by atmospheric conditions additionally, you can select between two pairs of limit values (see control by atmospheric conditions and limit ranges). The parameters for setpoint 1 (for setpoint switching) and setpoint min. 1 (for control by atmospheric conditions) are equal. Likewise the parameters setpoint 2 and setpoint min. 2. The corresponding content is assigned according to the configuration.

When activating the "control by atmospheric conditions" option and setting the adjustable parameters, you may realise an external setpoint default. In other words, the setpoint can be adjusted manually or automatically via a potentiometer (or switched through resistors). By connecting a change-over switch, you can implement a night-time reduction instead of control by atmospheric conditions. A control by atmospheric conditions and a night-time reduction can be realised simultaneously, if you combine the control by atmospheric conditions with the setpoint switching.

## 5 Firing Rate Controller (optional)

### 5.1.5 Start-up Sequence

The firing rate controller has a startup circuit, in order to slow down the burner's start firing rate. The startup circuit is run during each new burner start. The internal firing rate is held at a value P 792 adjustable by the user, for as long as the boiler is cold (actual value is below a user-adjustable limit, P 791). If the controller's actual value is equal to or larger than the parameterised startup maximum temperature, this startup circuit is cancelled.

In order to prevent a situation where an excessively large demand on system output, the boiler temperature necessary to cancel the startup circuit is not reached, a startup timer is also triggered in parallel (this timer can also be adjusted by the operator, P 793). Once the internal firing rate reaches the parameterised startup firing rate, the output is increased linearly step-wise up to the maximum firing rate. The slope of this linear increase is calculated from the parameterised startup time.

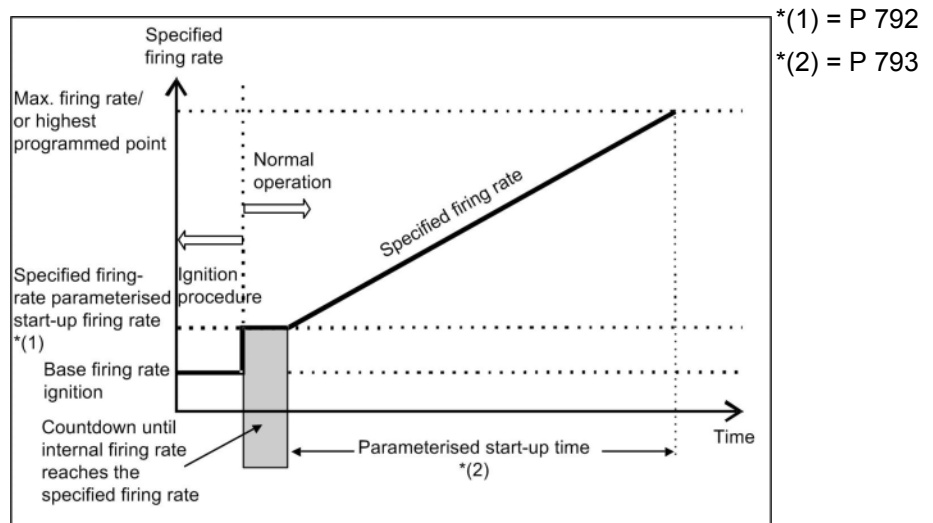

Fig. 5-2 Startup sequence

## 5 Firing Rate Controller (optional)

### 5.1.6 Thermostat and Control Range

The thermostat function switches the burner on and off on the basis of the temperature and/or pressure value, but only when burner is released by the start signal. The control range is formed by entering the controller setpoint value and the parameters P 802 (switch-on point), P803 (upper control range) and P 804 (burner OFF). The cut-off hysteresis is divided into 2 ranges. The first part lies above the setpoint and forms the upper control range. The second part lies below the setpoint and forms the lower control range.

The control range may lie asymmetrically around the setpoint.

The power control unit functions within the upper and lower control range according to its settings in the parameters and the default values.

If the actual value of the control unit reaches the shut-down range, the base firing rate request is emitted. If the control unit's setpoint exceed the shut-down range a control shut-off occurs. This is done by internal processing. If the actual value drops below the lower control range, a re-start can occur.

#### NOTICE

This function can replace the control thermostat, which is required on the plant.

**It does not replace a safety thermostat.**

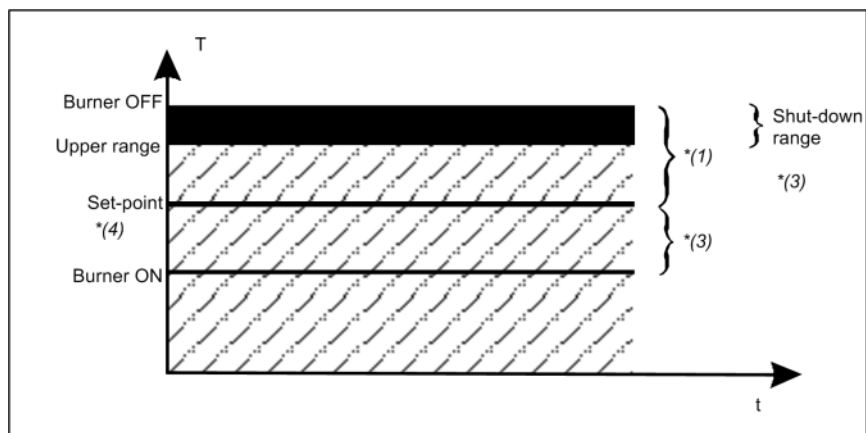
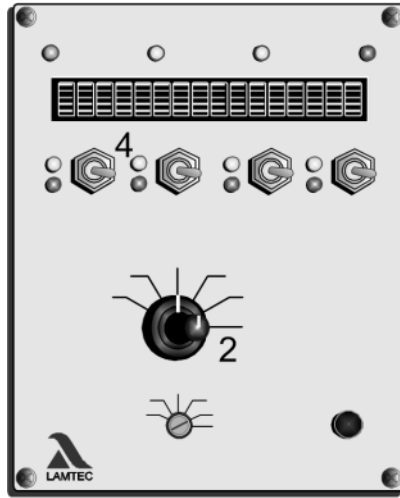

Fig. 5-3 Control range

## 5 Firing Rate Controller (optional)

### 5.1.7 Manual Control



The output controller's firing rate specification can be overwritten by turning the selector switch (2) to LOAD RATING (firing rate) and pressing the Channel 1 switch (4) upwards.

This manual firing rate control is cancelled by pressing the Channel 2 switch (4) downwards.

In manual mode, the shut-off limit can be found in Function (from software version 3.1 onwards). Hence you cannot use the manual mode to test the safety limiter.

#### CAUTION!

In manual mode, the firing rate controller's functions such as startup circuit and control thermostat are switched off. Therefore you should always monitor the system continuously when using manual control. You can check the safety limiter by changing the setpoint.

## 5.2 Control Setting

### 5.2.1 Meaning of the Display

Display in "FIRING RATE" switch position

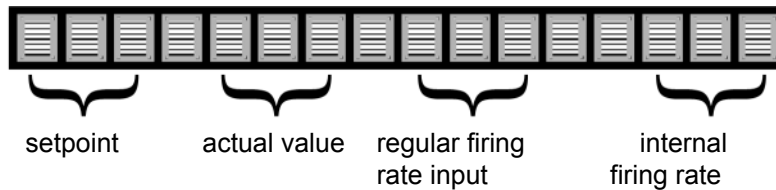

Display in mode "MANUAL"

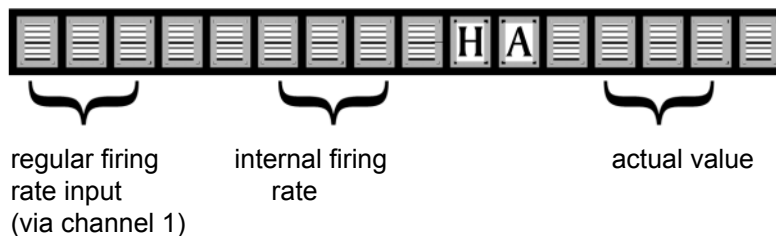

### 5.2.2 How to Adjust the Burner Firing Rate Controller

Only adjust the burner firing rate controller with the parameters.

## 5 Firing Rate Controller (optional)

### 5.2.3 Control Range

The control range lies around the setpoint. The content of the "Burner on" parameter is subtracted from the setpoint value to form the switch-on value. The value of the "Upper control range" parameter (P 803) is added to the setpoint value to form the upper limit of the control range. The control range may therefore lie asymmetrically around the setpoint. The shut-off range is upwardly limited by the "Burner off" parameter (P 804). The parameter is added to the setpoint value. If this value is exceeded, the burner is shut off.

The range between "Upper control range" and "Burner off" forms the shut-off range. If the actual value reaches this range, the to cancel firing rate controller, press key "Manual" again runs at base firing rate.

It also follows from this that the value in "Burner Off", is generally higher than that in "Upper control range". Otherwise there is no shut-off range and the burner is shut off on immediately reaching the limit.

The burner 'ON' switching point also can be located above the setpoint. In this case the parameter 802 has to be set negative (<0).

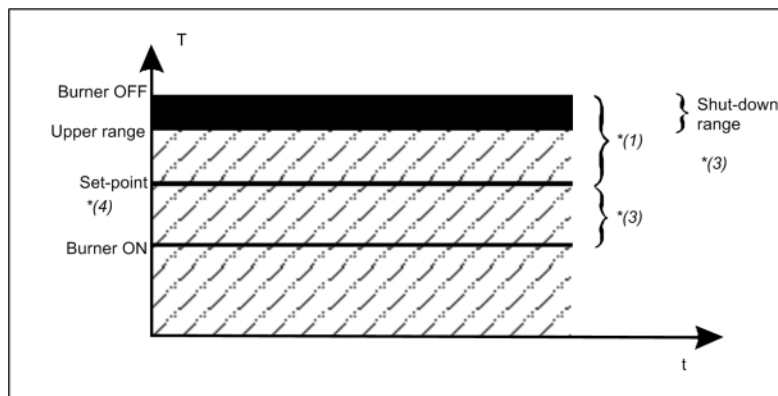

Fig. 5-4 Control range

### 5.3 Control Mode

The firing rate controller tries to bring the actual value into line with the setpoint value. In doing so, a direct correlation is assumed between internal firing rate and boiler temperature, e.g. the greater the internal firing rate, the faster the boiler temperature rises. Should the curves be programmed differently, the firing rate controller will not function.

Four parameters determine the control action.

- **Adjustment time**  
The adjustment time determines at what intervals the deviation is checked and the new adjustment is determined.
- **P term**  
The proportional term acts directly on the deviation, that is the difference between setpoint value and actual value.  
 $P > \rightarrow$  higher step response
- **I term**  
The integral term is calculated from the instantaneous deviation and the previous deviation from the setpoint value.

## 5 Firing Rate Controller (optional)

$I >$  → faster approximation to the setpoint  
danger of overshooting!

- **D term**

The derivative term is calculated from the variation of the actual values. It has acceleration and respectively slowing effects.

In practice the adjustment of the PID-controller is specified to each controlled system. With the characteristics of the controlled system you try to deduce acceptable data, i.e. the values are defined experimentally

- P term, I term, D term are added together and act as adjustment on the firing rate default for the ratio control. The value is added up, starting from the instantaneous internal firing rate.
- As long as the actual value is below the setpoint, P term and I term are positive, that is to say both these term will increase the firing rate default.
- Only the D term is negative in such a case (assuming that the boiler temperature is rising). Use the D factor sparingly because it leads to a higher burden of the actuators.
- In order to avoid excessive overshoot during burner start-up, the parameters should be adjusted to achieve a suitably large D-term.
- If, despite a large setpoint deviation, the burner is not running at full firing rate or base firing rate, the P term should be increased.
- The longer the adjustment time, the quieter the group. However, this also increases the actual value's deviation from the setpoint value and leads to slower adjustment.

	Hot Water Installations	Steam Boiler Installations
P term	120*	600
I term	60*	300
D term	20*	25
Adjustment time	15*	20

Values must be adjusted according to the controlled system.

\* Default value

Characteristic	Control Process	Control Mode	Start-up Procedure
P term higher	decrease of attenuation	stronger reaction with overshoot	faster start-up with overshoot
P term smaller	increase of attenuation	less reaction, less tendency to oscillate	slower startup

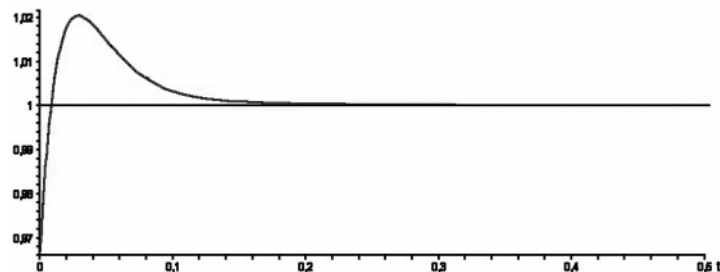

Fig. 5-5 Controller operation with P-term too high

Characteristic	Control Process	Control Mode	Start-up Procedure
I term higher	decrease of attenuation	stronger reaction with tendency to oscillate	faster start-up with tendency to oscillate

## 5 Firing Rate Controller (optional)

Characteristic	Control Process	Control Mode	Start-up Procedure
I term smaller	increase of attenuation	less reaction, less tendency to oscillate	slower start-up

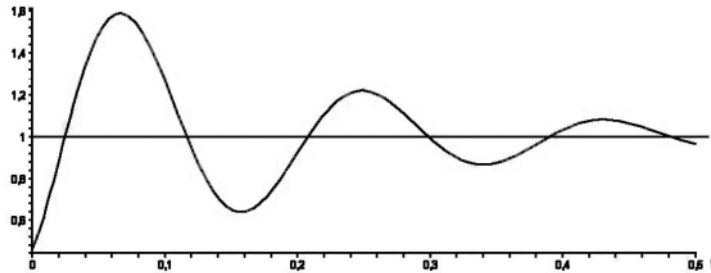

Fig. 5-6 Controller operation with I-term too high

Characteristic	Control Process	Control Mode	Start-up Procedure
D term higher	decrease of attenuation	stronger reaction	slower start-up, earlier decrease of power
D term smaller	increase of attenuation	less reaction	faster start-up, decrease of power later

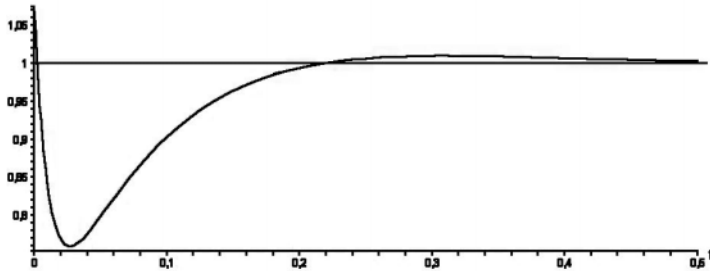

Fig. 5-7 Controller operation with D-term too high

## 6 Commissioning

### 6 Commissioning

#### 6.1 Before Commissioning

##### 6.1.1 Setting the Limit Switches of the Motors

As soon as the VMS is supplied with voltage, it attempts to drive the actuator motors to the lower limit of the factory set curve. If the end-bearing's limit switches are not properly adjusted for this, the motor may hit the actuator's mechanical stop

#### **WARNING!**

This may damage the motor or the valve.

Therefore:

Check the position of the end-bearing limit switches in the motors, taking into account the motor output shaft's travel.

If in doubt, set a shorter travel. It may be readjusted later.

#### 6.2 Function Test

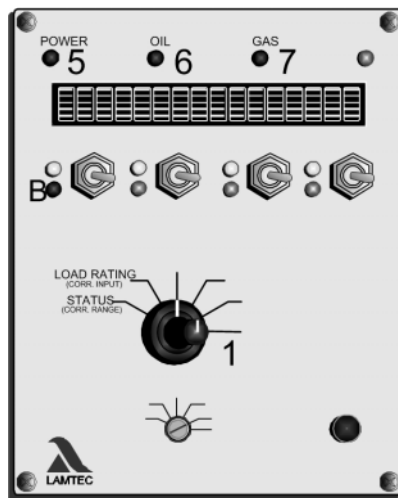

Signal on terminal 2 (Burner on) = 0

Control quantity (set point) = minimum. Turn selector switch (2) to AUTOMATIC.

Apply voltage to VMS:

→ VMS performs a self-test

→ The display shows the VMS and its software version briefly

Compare software version no. with sticker no.

→ Operating display (5) lights up

→ Fuel LED (6 or 7) lights up

→ The four CLOSED LEDs (B) light up

Turn selector switch (1) to status

→ The display shows BURNER OFF

Turn selector switch (1) to SET POINT

→ the display shows external regular firing rate input of 200

## 6 Commissioning

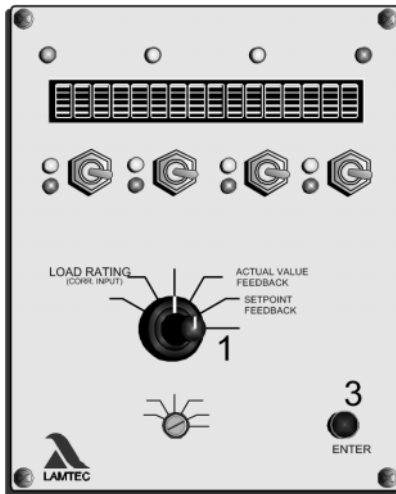

On a 4 channel unit:  
Turn selector switch (1) to DIGITAL INPUTS

On a 5 channel unit:  
Turn selector switch (1) to channel 5 display  
and  
select acceptance (3)  
→ the display shows status of the digital inputs  
→ — = input not activated  
→ ↑ = input activated

### 6.3 Significance of Digital Display

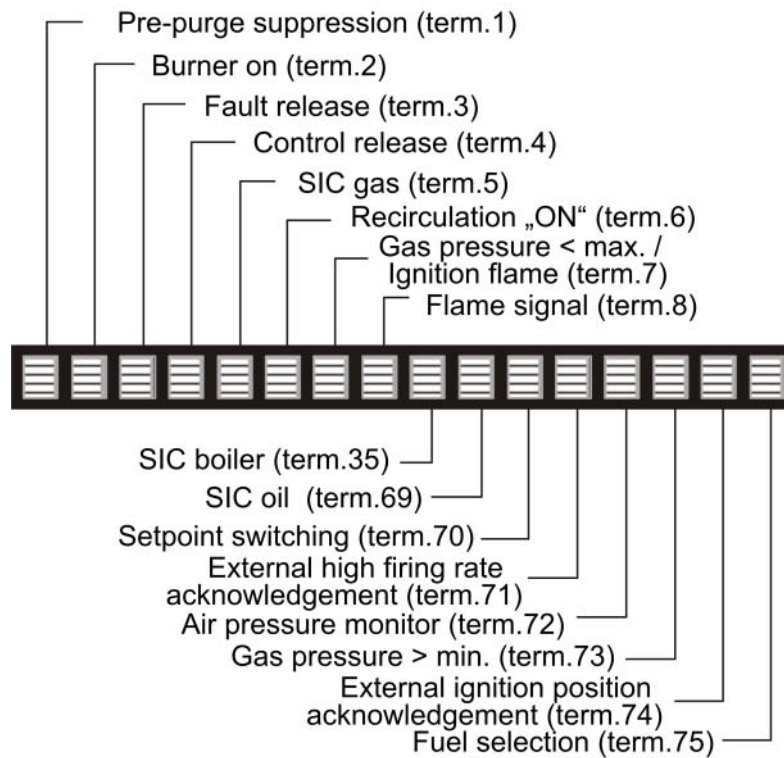

↑ = Signal present  
— = Signal not present

## 6 Commissioning

### 6.4 Adjusting Control Elements

#### 6.4.1 Operation Of Control Elements For Potentiometer Adjustment - Limit Switch Settings

##### NOTICE

“Setting” mode permits direct access to the control elements. It is therefore essential to follow the safety rules specified by the burner manufacturer!

##### NOTICE

Adjust the control elements only when the system is stationary.

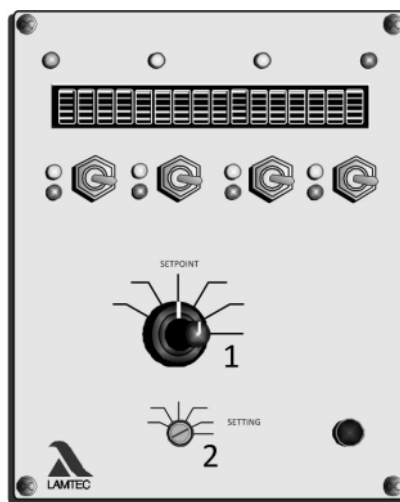

Turn selector switch (1) to ACTUAL VALUE FEED-BACK

Turn selector switch (2) to SETTINGS

→ The display shows 'E1'

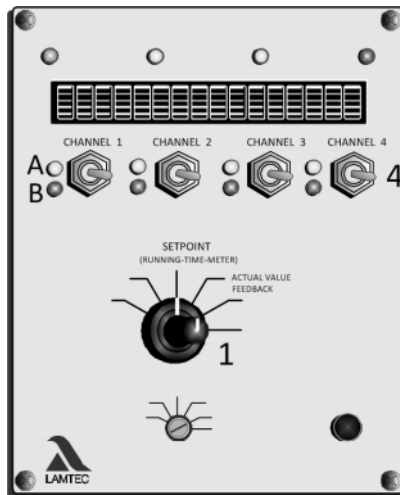

Set "Lower stop"

Set the setpoint for channel to "0" using key (4)

→ Red LED (B) lights up

→ Actuator responds

→ e.g. fan runs down or motor slowly going into CLOSE mode

Switch the limit switch to CLOSED. Adjust valve stop.

Programme the minimum r.p.m speed of frequency converter

Turn selector switch (1) to "ACTUAL VALUE FEED-BACK"

Adjust potentiometer to lower value (see table: Potentiometer adjustment values)

Set "Upper stop"

Turn selector switch (1) to 'SETPOINT'

Setpoint value = 999

Switch the limit switch to 'OPEN' - stop the flap

Check frequency converter's maximum r.p.m. speed

Turn selector switch to ACTUAL VALUE FEEDBACK.

Check upper potentiometer value (see table: Potentiometer adjustment values)

Check r.p.m. speed feedback value

## 6 Commissioning

### Potentiometer adjustment values (approximate)

Pot	Lower stop *	Upper stop *
5 k $\Omega$	80	920
1 k $\Omega$	200	800

\* provided that potentiometer r.p.m. range is fully utilised

## 6.5 Programming of Curves

### 6.5.1 Programming of Fuel/Air Ratio Control

#### NOTICE

Final programming of the unit with the burner stationary can only be done when it is certain that all feedback signals are present in the same way as when the burner is in operation (e.g. not temperature-dependent or active speed feedback). Otherwise programme when burner is in operation.

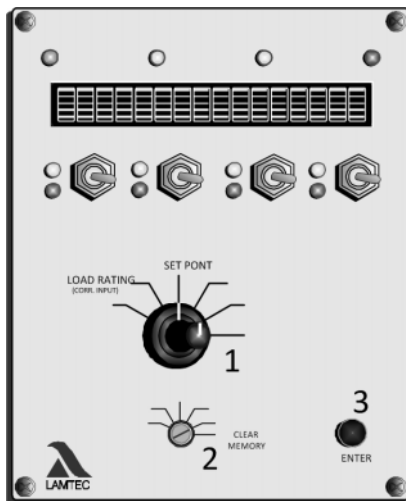

Select fuel

either with stationary burner  
Signal on terminal 2 (BURNER ON) = 0 Display AU

or

with burner in operation:  
Signal on terminal 2 (boiler thermostat) = 1

Wait until burner is on

#### NOTICE

Programming can only be performed with specified modes. Otherwise the unit registers a fault and will accept no inputs. It may be necessary to wait for the automatic combustion sequence control to release the control before programming when the burner is in operation (via mode 'EV', 'EZ', 'EG').

If burner locks out whilst programming in process e.g. owing to control shut-off  
→ see chapter 8.1.4 *Proceed with Programming*

If FMS skips to 'ES' mode whilst programming is in progress  
→ see chapter 8.1.4 *Proceed with Programming*

## 6 Commissioning

### 6.5.2 Entirely New Curve - Clear Memory

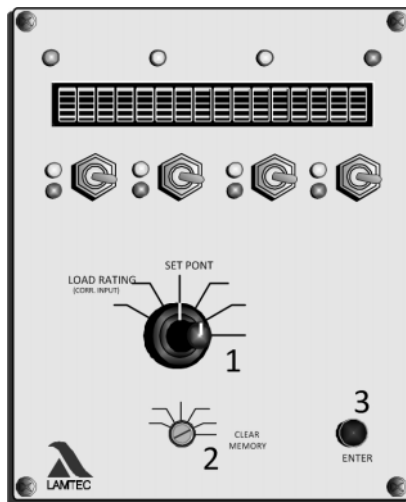

Turn selector switch (1) to SETPOINT  
Turn selector switch (2) to CLEAR MEMORY  
→ 'SL' appears in centre of display  
Press ENTER (3):  
→ 'cleared' appears on display

#### NOTICE

When programming the ignition firing rate point for the first time, it is recommended that the VMS be initially started. At the end of the pre-purge time, all channels close. As soon as a switch is operated the 'EI' mode is reactivated and the ignition point can be set

### 6.5.3 Programming 1<sup>st</sup> Point (Separate Ignition Point)

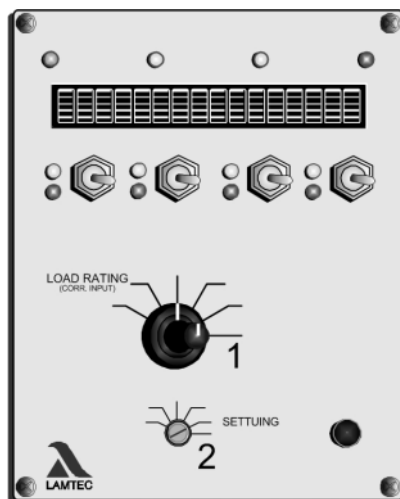

Turn selector switch (2) to SETTING  
→ 'EI' appears in the middle of the display

#### For safety reason:

SETTING mode permits direct access to the control elements with the burner running. It is therefore essential to follow the safety rules specified by the burner manufacturer!

SETTING mode with the system running must only be undertaken by trained and experienced personnel, whilst keeping a constant watch on the system.

The first point entered after clearing the memory is always the ignition firing rate point. This is fixed at a firing rate rating that can no longer be run during an operation (setpoint 002)

## 6 Commissioning

### 6.5.4 Programming While The Burner Is Running

(pre-purge has been carried out previously without programmed point)

Start burner and wait for pre-purge period.

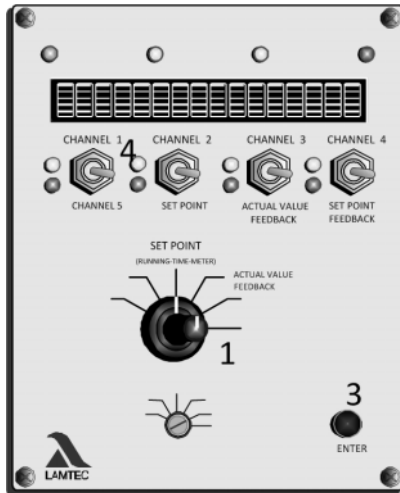

Turn selector switch (1) to SETPOINT  
Switch (4) up or down  
until system is optimally adjusted at ignition firing rate  
point.

on VMS 5:

→ setpoint value and feedback actual value are displayed

Switch (4) (channel 2) up or down until channel 5 is optimally adjusted.

Turn selector switch (1) to ACTUAL VALUE FEEDBACK

→ Value of external feedback (with continuous output) is displayed

→ with three-point step channel, the same value as in SETPOINT setting would be displayed

Wait until feedback has stopped

Press ENTER (3)

→ 'Really ignite?' appears on display

#### NOTICE

By operating the switch (4), the ignition point setting can be corrected again.

Press ENTER (3) again

→ burner ignites

→ sep. ignition point appears on display

## 6 Commissioning

### 6.5.5 Programming While The Burner Is Stationary

#### NOTICE

The monitoring values may clearly deviate from the values of the main processor, depending on the configuration (redundant signals or not). It is essential that the actual value matches the setpoint value of the respective processors, not the correspondance of values between the processors.

#### NOTICE

- ▶ Should there be any redundant feedbacks, the curves must be programmed on a burner during operation.

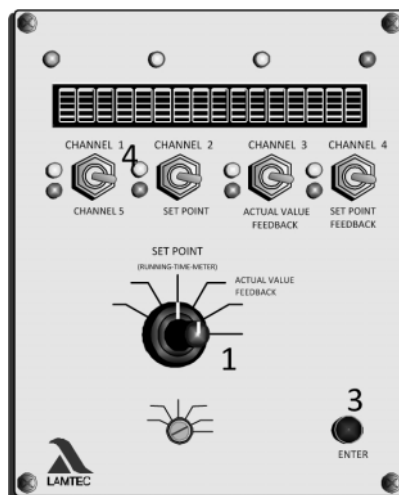

Turn selector switch (1) to SETPOINT

Switch (4) up or down

until system is optimally adjusted at instantaneous firing rate

on VMS 5

→ setpoint and actual value feedback are displayed

Switch (4) Channel 2 up or down until channel 5 is optimally adjusted

Turn selector switch (1) to ACTUAL VALUE FEEDBACK

→ the display shows the value of the external feedback.

→ at the three-point-step channel the display shows the same value as in the setpoint setting.

Press ENTER (3)

→ SZP-POINT appears on the display.

## 6 Commissioning

### 6.5.6 Programming 2<sup>nd</sup> to 20<sup>th</sup> Point

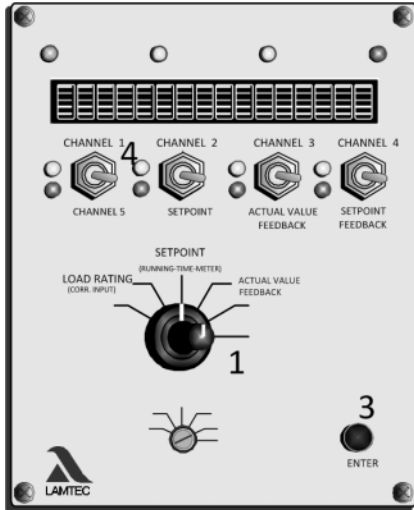

Set selector switch (1) to "firing rate rating".  
Run to desired firing rate rating using channel 1 switch.

Set selector switch (1) to "setpoint"  
Switch (4) up or down until system is optimally adjusted at instantaneous firing rate

On VMS: Selector switch (1) to "Channel 5 display"  
– setpoint and actual value feedback are displayed.

Switch (4) (channel 2) up or down until channel 5 is optimally adjusted

Selector switch (1) to "Actual value feedback"  
Wait until feedback has stopped

Press Acceptance (3)

– Point X appears on the display (X is the number of the programmed point.  
That is, at the 4 press of the acceptance key, point 4)

#### NOTICE

A firing rate point on the curve must be the lowest possible firing rate that can be preset by the firing rate control unit in operation, otherwise the fuel/air ratio control cannot completely follow the firing rate control unit. The fuel/air ratio control does not go below its lowest point even in the event of lower firing rate requirements.

## 6 Commissioning

### 6.5.7 Programming Last Top Point

Selector switch (1) to "Firing rate rating"

Run to top firing rate rating

→ 999 on the display (corresponds to 20 mA as firing rate input)

#### NOTICE

It is essential to run to the highest firing rate that can be preset by the firing rate control unit in operation, otherwise the fuel/air ratio control cannot completely follow the firing rate control unit. The fuel/air ratio control does not go above its highest point even in the event of higher firing rate requirements.

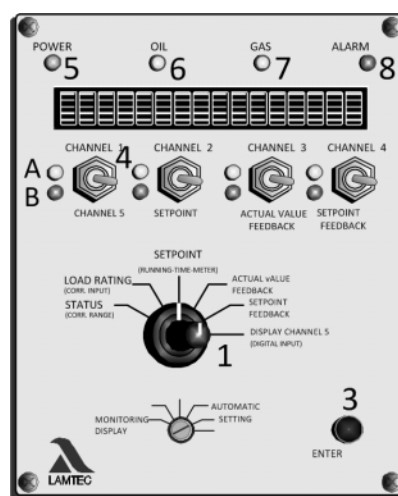

Selector switch (1) to "setpoint"

Switch (4) up or down until system is optimally adjusted at instantaneous firing rate

On VMS 5: Selector switch (1) to "Channel 5 display"  
→ setpoint and actual value feedback are displayed

Switch (4) (channel 2) up or down until channel 5 is optimally adjusted

Selector switch (1) to "Actual value feedback"

Wait until feedback has stopped.

Press Enter key (3)

→ Point X appears on the display

### 6.5.8 Saving Curve

Turn selector switch (2) from SETTING to AUTOMATIC

→ the display shows MEMORY briefly. The curve has been transferred into EEPROM

## 6 Commissioning

### 6.5.9 Check Monitoring Values

---

Turn selector switch (2) to MONITORING DISPLAY

– The display switches to the values of the monitoring section

Turn selector switch (1) to FIRING RATE RATING (firing rate)

Move to programmed firing-rate rating

Turn selector switch to SETPOINT or ACTUAL VALUE FEEDBACK

#### **NOTICE**

The monitoring values may clearly deviate from the values of the main processor, depending on the configuration (redundant signals or not). It is essential that the actual value matches the setpoint value of the respective processors, not the correspondance of values between the processors.

---

#### **NOTICE**

Should there be any redundant feedbacks, the curves must be programmed on a burner during operation.

---

### 6.5.10 Adding Points

Should there be a previously saved curve that does not contain twenty points, additional points may be added.

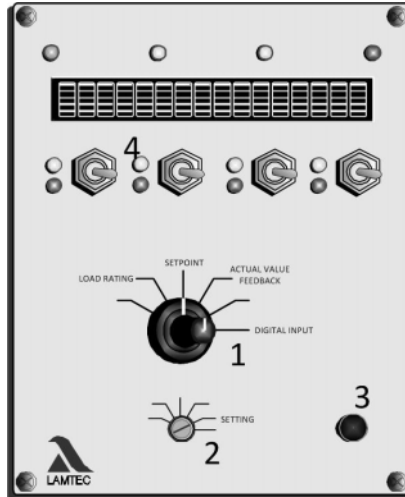

Turn selector switch (2) to SETTINGS

Turn selector switch (1) to FIRING RATE RATING (firing rate)

Run to desired firing rate

If the display shows a flashing number after the firing-rate rating, instead of adding a new point an old one is overwritten.

Turn selector switch (1) to SETPOINT

Switch (4) up or down until system is optimally adjusted at the selected firing-rate rating.

VMS 5: Switch (1) to DISPLAY CHANNEL 5

→ the display shows setpoint and actual value feedback

Switch (4) channel 2 up or down until channel 5 is optimally adjusted.

Turn selector switch (1) to ACTUAL VALUE FEEDBACK

Wait until feedback has stopped.

Press ENTER (3)

→ Point X (number of the new firing rate rating appears on the display, if 6 points have previously been entered, 'Point 7' appears, only then is it classified according to its value)

if necessary add further values

otherwise store

note monitoring values

#### NOTICE

Up to 20 points can be programmed. A high resolution should also be used, since this ensures precise combustion control. It is also possible, however, to store fewer than 20 points. This is advisable, for example when entering an initial, approximate curve.

#### NOTICE

A definitive curve for the VMS should always comprise at least 10 points.

## 6 Commissioning

### 6.5.11 Change Curve Point

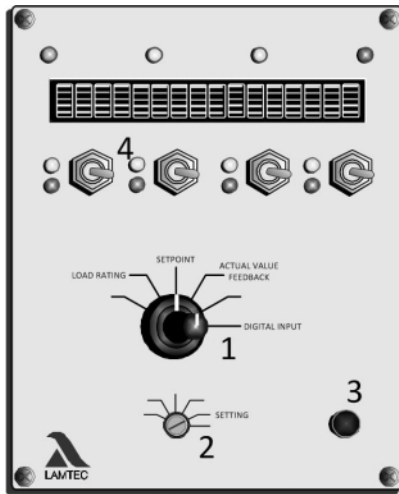

Turn selector switch (2) to SETTINGS

Turn selector switch (1) to LOAD RATING (firing rate)  
Using switch (4) channel 1, run to firing rate of the setpoints which are to be changed. Recognisable by flashing digits after firing rate, e.g. 700 (8)

The display must show a digit or 'Z' after the firing rate, otherwise the VMS does not accept the change and a point may be accidentally added.

Turn selector switch (1) to SETPOINT

Switch (4) up or down until system is optimally adjusted at the selected firing rate.

VMS 5: Turn selector switch (1) to DISPLAY CHANNEL 5

→ the display shows setpoint and actual feedback

Switch (4) channel 2 up or down until channel 5 is optimally adjusted.

Turn selector switch (1) to ACTUAL VALUE FEEDBACK

Wait until feedback has stopped.

Press ENTER (3)

→ Point X (number of the new firing rate) appears on the display

if necessary change another curve point

otherwise Save

Check monitoring values

#### NOTICE

The separate ignition point can also be started up and changed in this way.

## 6 Commissioning

### 6.6 O<sub>2</sub> Trim

#### 6.6.1 Automatic Function Monitoring During Operation

##### 6.6.1.1 Adjusted The Integrated O<sub>2</sub> Controller (Optional)

This section explains only the operating steps needed to input the O<sub>2</sub> curve. Further information on O<sub>2</sub> controller is contained in the publication DLT 5002 Commissioning Supplement for the Optional 'Integrated O<sub>2</sub> Controller'.

##### 6.6.1.2 Test During Burner Start

The actual O<sub>2</sub> value is checked to ensure that during pre-purge it corresponds to the air value (equal to or greater than 18 vol.% O<sub>2</sub> and less than 24 vol.% O<sub>2</sub>).

After ignition, the actual O<sub>2</sub> value must reach a value equal to or below 14% within 45 seconds. Reaching the threshold value is monitored. If one of the two parameters is not met, O<sub>2</sub> trim is deactivated. The control unit outputs the value "Base value without control".

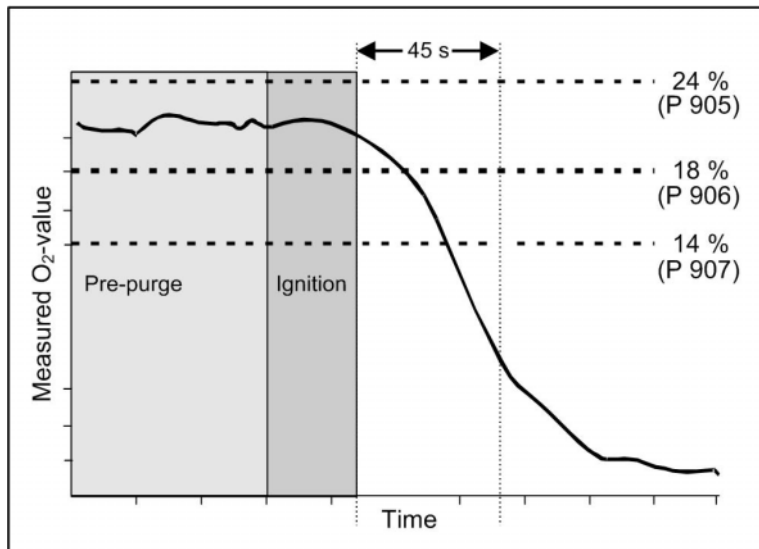

##### 6.6.1.3 O<sub>2</sub> Monitoring Band

During burner operation, the actual O<sub>2</sub> value is continuously monitored for one maximum and two minimum permissible values. These ranges are located around the O<sub>2</sub> setpoint as a function of firing rate. If the actual values stay outside these bands for a defined period, the control system is deactivated and a "Fault" warning is output.

Thereafter, the control unit's output (correction input) corresponds to "Base value without control" or "Base value with air deficiency".

## 6 Commissioning

### 6.6.1.4 O<sub>2</sub> Limit Curve

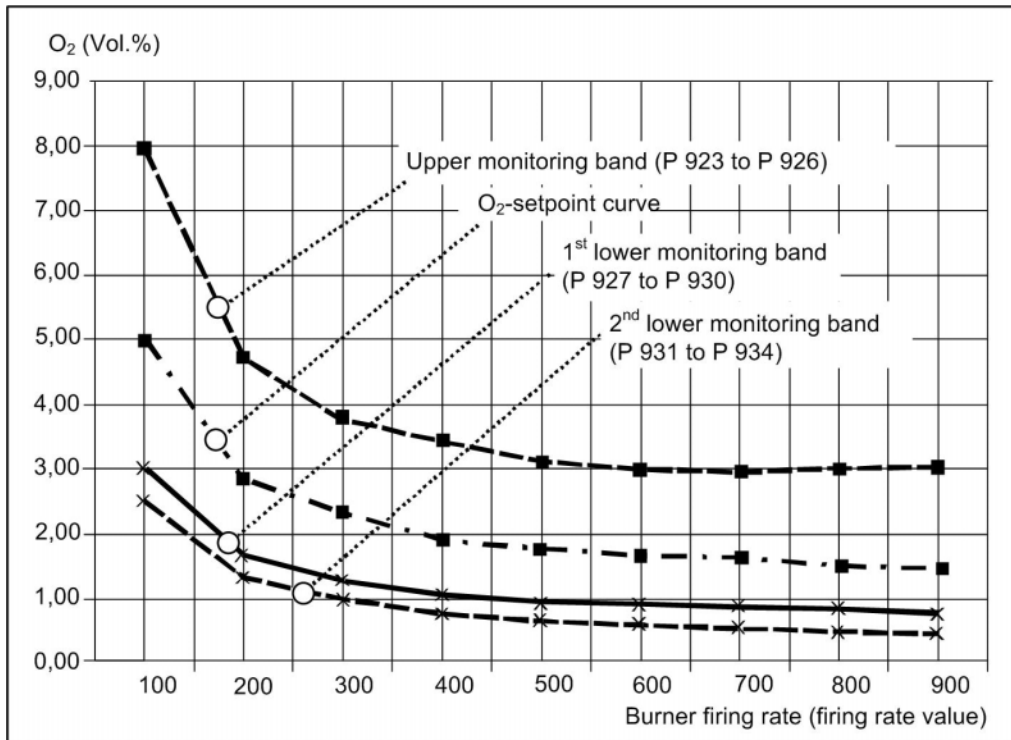

You can set the monitoring bands' parameters for 2 fuels, oil/gas, as a function of fuel. The permitted deviation is calculated as a percentage of the setpoint. You can specify two separate percentage values for base firing rate and full firing rate. The section between is interpolated linearly.

#### Monitoring/shutdown times:

1<sup>st</sup> monitoring band: 120 seconds; active after "Control on".

2<sup>nd</sup> monitoring band: 30 seconds; active after "Burner on".

#### Factory setting

1<sup>st</sup> monitoring band, upward direction

– Base firing rate (parameters 923 / 925) 60%

– Full firing rate (parameters 924 / 926) 100%

1<sup>st</sup> monitoring band, downward direction

– Base firing rate (parameters 927 / 929) 40%

– Full firing rate (parameters 928 / 930) 50%

2<sup>nd</sup> monitoring band, downward direction (may be modified during commissioning)

– Base firing rate (parameters 931 / 933) 50%

– Full firing rate (parameters 932 / 934) 70%

### 6.6.1.5 Dynamic Probe Test

---

The VMS monitors the measured O<sub>2</sub> value for changes during operation. If a fluctuation no higher than 0.2 O<sub>2</sub> vol.% is detected over a period of 10 minutes, a state of excess air is enforced by changing the fuel/air mixture. If there is still no change in the actual O<sub>2</sub> value after 1 minute, the test is repeated with more excess air. If this does not lead to a change in the actual value, the test is performed a third time with even more excess air. If no change has occurred in the actual O<sub>2</sub> value at this point, the control unit deactivates itself and displays a warning on the screen. Thereafter the control unit's output (correction input) corresponds to "Base value without control".

#### **NOTICE**

The O<sub>2</sub> optimisation fault messages do not affect burner or combustion functions.

---

### 6.6.1.6 Probe Blockage

---

Blockages in the probe can cause the measured value to increase slowly but steadily, in such a way that the dynamic probe test is not triggered. The main processor monitors whether the actual O<sub>2</sub> value drops by more than 0.2 vol. % O<sub>2</sub> at least once within 15 minutes. If this is not the case, then a dynamic test is triggered.

#### **NOTICE**

O<sub>2</sub> optimisation fault messages have no effect on the burner's function or that of the combustion system. They only notify that:

- O<sub>2</sub> optimisation was deactivated.
- Note error status and firing rate value.

If desired, it is also possible to have the burner shut down on 'Air shortage' faults via parameter 897.

---

## 6 Commissioning

### 6.6.1.7 Correction Output Monitoring

The controlling strategies employed were specially developed and optimised for the circumstances prevailing in combustion facilities:

- Frequent output changes
- long lag time

During burner start-up, the O<sub>2</sub> controller remains on standby until it is ensured that plausible O<sub>2</sub> measured values are being displayed. Factory setting 90 seconds after ignition - this is adjustable via parameter (P 904).

During standby and ignition mode, the value for deactivated control would be given (see Fig. 6-1 Correction output monitoring).

It is calculated automatically from the range set.

Ignition takes place with the neutral value.

The neutral value depends on the selected correction mode; e.g. at -50% to +50%, the output correction value (neutral value) is 500, whilst at -30% to +70% it is 300.

#### NOTICE

The natural value correspond to the basic settings of the VMS without control

In the case of fuel/curve switching during operation, the neutral value is output during the switch-over. An air advance can be set to the neutral value by parameters 702 to 704.

O<sub>2</sub> trim is reactivated, with a time delay, once the switch-over is completed. Factory setting 30 seconds, adjustable via parameter (P 903).

Various control strategies are available.

In the event of a fault, 'O<sub>2</sub> trim base value deactivated' or 'Base value for air shortage' is output, depending on the cause.

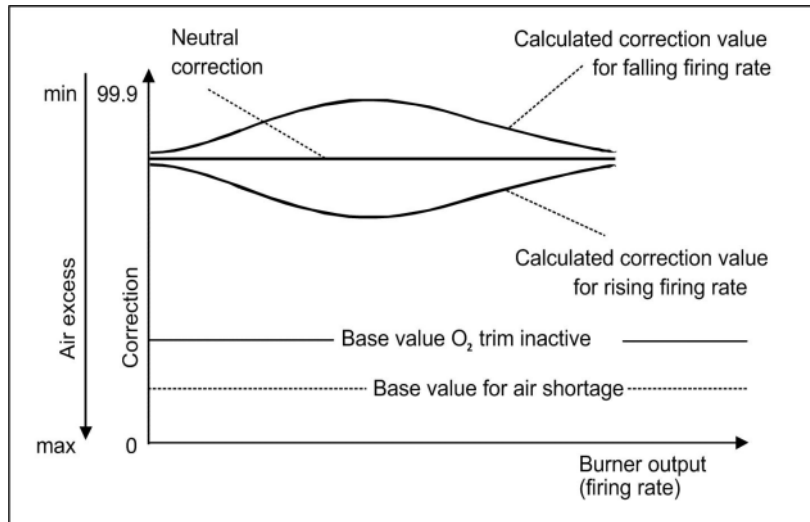

Fig. 6-1 Correction output monitoring

## 6 Commissioning

### 6.6.2 Control Strategy

#### 6.6.2.1 With Pre-setting For Firing Rate Changes

O<sub>2</sub> trim by means of a comparison between target and actual values is only performed if no output change (firing rate change) takes place ('internal firing rate' static). After a preceding firing rate change, an target/actual value comparison is performed and an actuation step triggered only after expiry of the set lag time (parameters 898 and 900).

If the O<sub>2</sub> actual value corresponds to its target value, the current correction value, referenced to the firing rate value and the firing rate direction, is stored in a table. The updated value is output at the next firing rate change.

A pre-update is already carried out as from the 2<sup>nd</sup> target/actual value comparison, after a firing rate change. As soon as the actual value gets close to the target value, the correction value is updated.

When the firing rate changes, control is terminated immediately after target/actual value comparison and the neutral value, or if relevant the correction value obtained (updated) for this firing rate point, is output → pre-setting!

Control after a target/actual value comparison is only performed again if the firing rate is stationary and on expiry of the lag time.

In this type of control, the overshoot is automatically deactivated in the VMS. The actuators' hysteresis is compensated for by the firing rate direction-dependent updating of the correction value.

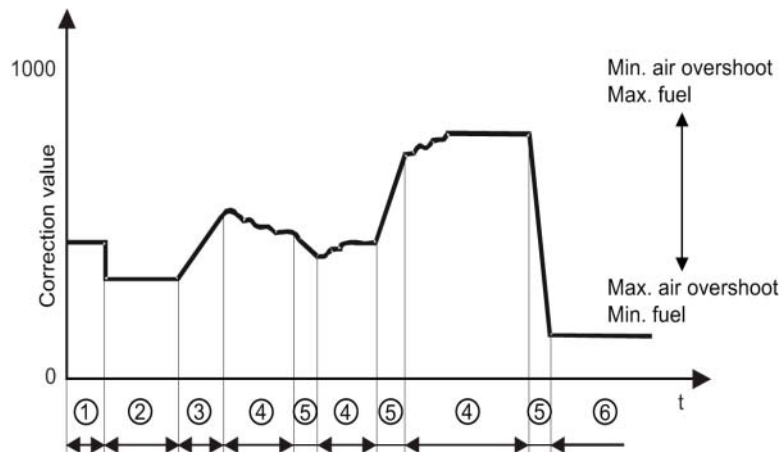

#### Control strategy with pre-setting for firing rate changes

- 1 Pre-purge/ignition  
The correction is switched off; i.e. the neutral correction value is output.
- 2 O<sub>2</sub> trim on standby the "Correction value with deactivated controller" specified in parameter 901/902 is output.
- 3 Controller takes over the neutral correction value, or the updated correction value is output.
- 4 On expiry of the set lag time, the residual deviation between target and actual value is corrected.
- 5 firing rate change  
O<sub>2</sub> trim is suspended and pre-setting carried out - neutral correction value, or the updated correction value is output.
- 6 Control is deactivated, e.g. by a fault  
The correction value for deactivated controller specified in parameter 901/902, or the one specified in parameter 917/918 for 'Air shortage', is output.

## 6 Commissioning

Parameter 896 can be used to select whether the pre-setting is always (at each firing rate change) to be activated (factory setting Standard 1), or not activated (content 2).

Furthermore, the updating too can be turned off. It is then possible to select whether, at firing rate changes, the neutral correction value or the 'Base value without controller' is to be output (parameter 896). The overshoot becomes active again when updating is turned off.

### 6.6.2.2 Extended Control Strategy (Air Shortage)

---

Regardless of the selected control strategy and the lag time set (parameter 898/900), immediate and extensive action is taken by the controller to combat any air shortage occurring. The objective is to avoid air shortage and to correct any such shortage as quickly as possible.

Controller overshooting and the resulting excess air are accepted as unavoidable.

## 6 Commissioning

### 6.6.3 Connecting the O<sub>2</sub> Measurement Device

#### 6.6.3.1 Via Analogue Interface

The default for the measured O<sub>2</sub> value is set via standard signal 0/4...20 mA to the VMS correction input 1.

 **WARNING!**

Only O<sub>2</sub> meters whose t<sub>90</sub> response time is < 15 sec may be connected.

Release of the analogue interface is only possible at the factory (type 663R0030). In case of doubt, please contact LAMTEC.

Range compensation via parameters P 919 and P 920

Factory setting: 4 ... 20 mA ⇔ 0 ... 25,0 vol. % O<sub>2</sub>

0 mA when O<sub>2</sub> measurement is at fault

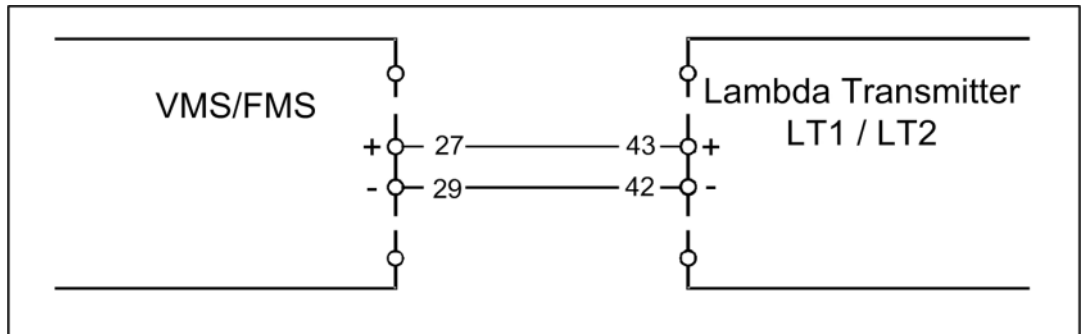

Fig. 6-2 Electric connection VMS O<sub>2</sub> measurement device

Terminal	Description
27/29	Correction input 1
42/43	Analogue output 1 *

\* floating type 657R0051

## 6 Commissioning

### 6.6.4 Operating Control and Displays

#### 6.6.4.1 Mode Switching

Turn selector switch (1) to STATUS.

Channel key 3 in upward position → the display shows O<sub>2</sub> trim.

Turn selector switch to STATUS position → the display shows O<sub>2</sub> actual value and O<sub>2</sub> target value. If O<sub>2</sub> trim is deactivated, the figures are shown in parentheses.

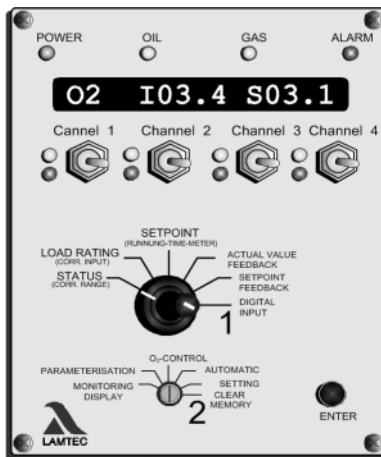

Fig. 6-3 O<sub>2</sub> trim activated

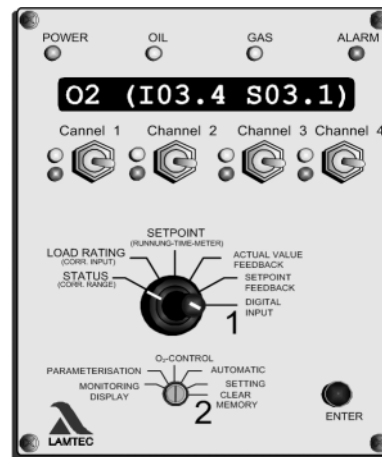

Fig. 6-4 O<sub>2</sub> trim deactivated

#### NOTICE

O<sub>2</sub> actual and target values are only displayed if O<sub>2</sub> trim or O<sub>2</sub> display are activated by parameter 896.

In AUTOMATIC operation, the display switches during regular operation to the O<sub>2</sub> trim mode. During burner start-up and with the basic firing rate, VMS text mode is active - basic setting

However, switching the display by means of channel key 3 is always possible. Nevertheless, the manually preselected setting only remains in force until the next change-over into 'Regular operation' or 'Basic firing rate control', and then returns automatically to the basic setting.

In 'O<sub>2</sub> trim' mode, and with the selector switch in the STATUS position, pressing the ENTER key calls up commentary texts (running texts) relating to O<sub>2</sub> trim.

The selector switch position (2) O<sub>2</sub> trim serves only for the input of O<sub>2</sub> target value curves.

## 6 Commissioning

### 6.6.4.2 Calling up O<sub>2</sub> Trim Text Messages

---

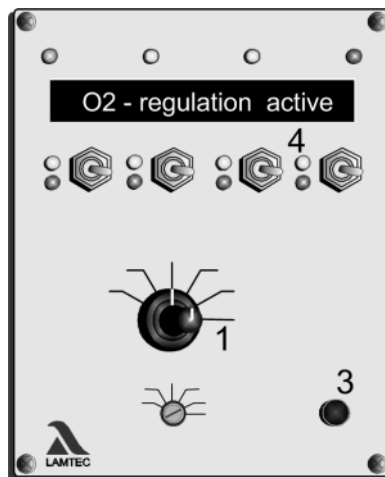

Switch display to O<sub>2</sub>-trim.  
Turn selection switch (1) to STATUS,  
Push channel key 3 (4) upwards

Press the ENTER key (3) to call up the indication.

Back → press ENTER key again (3),  
or turn selection switch (1) to another position.

## 6 Commissioning

### 6.6.5 Commissioning

#### 6.6.5.1 Correction Output Monitoring

The controlling strategies employed were specially developed and optimised for the circumstances prevailing in combustion facilities:

- Frequent output changes
- long lag time

During burner start-up, the O<sub>2</sub> controller remains on standby until it is ensured that plausible O<sub>2</sub> measured values are being displayed. Factory setting 90 seconds after ignition - this is adjustable via parameter (P 904).

During standby and ignition mode, the value for deactivated control would be given (see *Fig. 6-5 Correction output monitoring*).

It is calculated automatically from the range set.

Ignition takes place with the neutral value.

The neutral value depends on the selected correction mode; e.g. at -50% to +50%, the output correction value (neutral value) is 500, whilst at -30% to +70% it is 300.

#### NOTICE

*The natural value correspond to the basic settings of the VMS without control*

In the case of fuel/curve switching during operation, the neutral value is output during the switch-over. An air advance can be set to the neutral value by parameters 702 to 704.

O<sub>2</sub> trim is reactivated, with a time delay, once the switch-over is completed. Factory setting 30 seconds, adjustable via parameter (P 903).

Various control strategies are available.

In the event of a fault, 'O<sub>2</sub> trim base value deactivated' or 'Base value for air shortage' is output, depending on the cause.

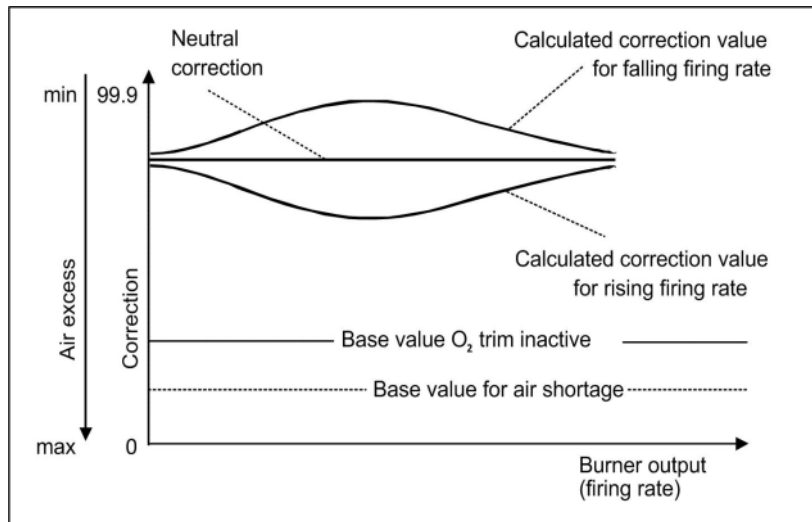

*Fig. 6-5 Correction output monitoring*

#### 6.6.5.2 Enter the O<sub>2</sub> setpoint curve

Calculation of O<sub>2</sub> target values as part of burner adjustment

## 6 Commissioning

The  $O_2$  values calculated during burner adjustment are input and stored as follows, regardless of whether the burner is off or in operation. The  $O_2$  target values can be input arbitrarily. It is not necessary to observe any particular sequence.



Turn selector switch (2) to  $O_2$  TRIM

Delete the whole  $O_2$  curve with channel key 4 (4) upwards.

If only points need to be changed, push channel key 4 (4) downwards.

Turn selector switch (1) to FIRING RATE RATING (firing rate).

Using channel key 1 (5), the composite curve's programmed firing rate points can now be called up.

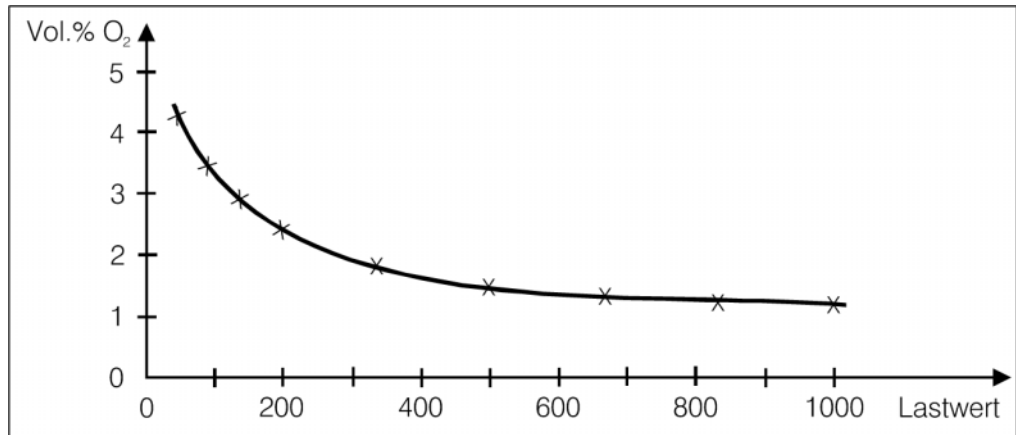

Fig. 6-6 Typical  $O_2$  target value curve

### NOTICE

The  $O_2$  target values can only be stored in the programmed firing rate points. If firing rate points are skipped, the line in between is interpolated.

- Switch (1) to target value.
- Channel key 4 (4) is used to set the required  $O_2$  target value.
- Press the Enter key (3).

### NOTICE

Each stored  $O_2$  target value can be changed as many times as necessary, including immediately after storing it.

Switch (3) to firing rate and use channel key 1 (5) to call up the next firing rate point; etc.

As soon as all required  $O_2$  target values have been entered, switch (2) back to Automatic.

.The  $O_2$  target value curve is now stored.

## 6 Commissioning

### 6.6.5.3 Changing the O<sub>2</sub> setpoint curve

Vorgehensweise wie unter Eingabe von O<sub>2</sub>-Sollwert beschrieben.  
Kanaltaster 4 (2) jedoch anstelle nach oben nach unten drücken.  
Turn selector switch (1) to Status

### 6.6.5.4 Calling up the Set Correction Mode

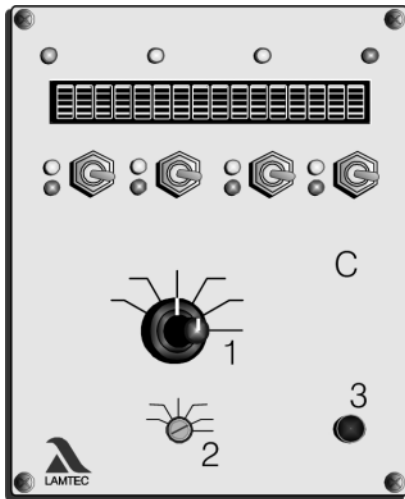

Turn selector switch (1) to STATUS  
Press ENTER (3)  
→ The display shows the selected correction range  
If both correction inputs operate on one channel, the sums are shown (e.g. 15 points).  
Press ENTER (3) again, or  
Turn selector switch (1) back  
→ return to normal display

The correction should be taken into account during later programming. The correction should be able to take effect before the VMS reaches actuator stop.

### 6.6.5.5 Calculation Of Control Parameters

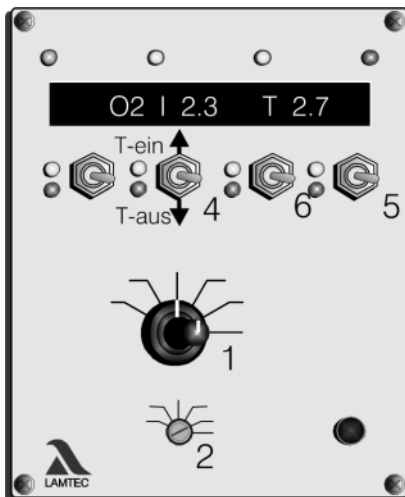

Run burner on low firing rate.  
Turn selector switch (2) to O<sub>2</sub> TRIM  
→ The display shows a text message  
Push channel key 4 (5) downwards  
→ Text message disappears from the display  
Turn selector switch (1) to target value  
Push channel key 2 (4) upwards  
→ The O<sub>2</sub> controller is activated when this is set, visible through the display T  
The O<sub>2</sub> target value can now be adjusted using channel key 3 (6) within a range of +3 to -1 vol.% O<sub>2</sub> from the target value entered. The change in the actual O<sub>2</sub> value can be observed on the display at the same time.  
Channel key 3 (6) upwards → more O<sub>2</sub>  
Channel key 3 (6) downwards → less O<sub>2</sub>

The setting of parameters P 898/P 899 and P 900 should be such that the next target/actual value comparison (actuation pulse) takes place only if the O<sub>2</sub> actual value has changed discernibly. A symbol +;- at the centre of the target value display indicates that a target/actual value comparison is being performed.

No change or change too small: → Increase P-factor parameter 899.

## 6 Commissioning

### NOTICE

The P-factor (proportionality factor, parameter 899) is specified by the parameter setting. The new correction is obtained from two input quantities, deviation and P-factor. This would be transmitted to the VMS as an output. The procedure is repeated after lag time's expiry. If the internal firing rate has changed during this time, the O<sub>2</sub> controller exits this routine. It must then be reactivated again as described above, via channel key 2 (4).

Deactivate test mode  
Select channel key 2 (4) downwards

#### 6.6.5.6 Lag time (Parameters 898 / 900)

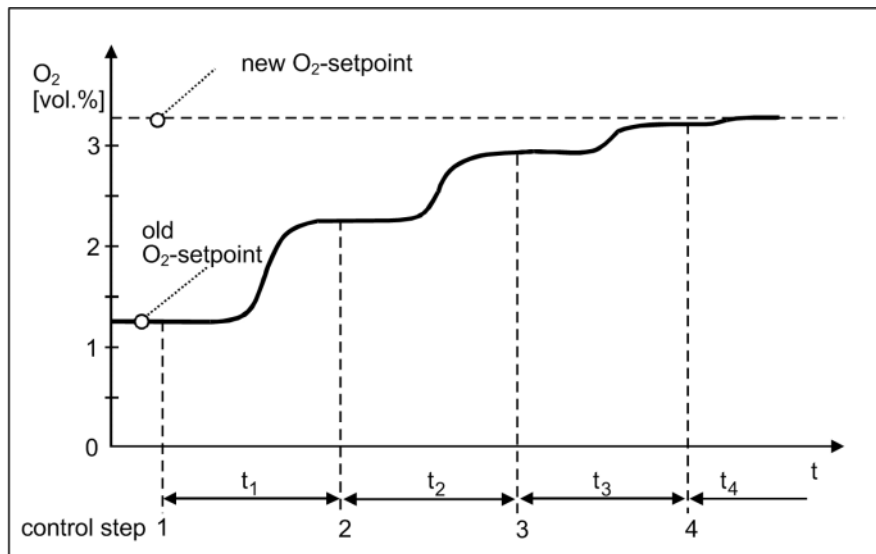

Setting the control parameter:

$t_1 \text{ --- } t_4 =$  controlled system's dead time

Specified by parameters 898 and 900.

The calculated value should be entered into parameter 898.

Factory setting: 15 seconds.

In parameter 900, the dead time can be adjusted according to the firing rate.

The dead time is reduced at full firing rate, due to the high gas velocities.

Factory settings: dead time is reduced by 3 seconds

To calculate dead time at full firing rate: proceed as described above.

Guideline for 2 or 3-draught boiler:

Parameter 898 → 12 seconds

Parameter 900 → 3 seconds

The P-factor should be adjusted so that a target/actual value deviation of 1...2 vol.% O<sub>2</sub> is corrected within 4...6 steps without overshooting.

#### 6.6.5.7 P-factor (Parameter 899)

Actuation pulse too short → increase P-factor in parameter 899

Overshooting → reduce P-factor in parameter 889

Repeat until the target value is corrected within approx. 4 ... 6 steps.

Check controller setting at intermediate and full firing rate.

## 6 Commissioning

### NOTICE

It is possible to achieve optimisation by manipulating P-factor (parameter 899) and dead time (parameters 898 and 900), that inter alia also depends on the installation's properties; e.g. one may set a somewhat shorter dead time if the P-factor is reduced at the same time.

#### Recommendation:

Set a slightly longer regulation cycle and smaller P-factor → higher safety!

### 6.6.5.8 Setting a Base Value for "Deactivated controller" and "Air shortage"

Parameters 901 and 902  
Parameters 917 and 918

During fault, O<sub>2</sub> trim would deactivate these and depending on the cause, the specified correction value for "deactivated O<sub>2</sub> controller" or "air shortage" would be displayed as an output. The burner would not shut down.

Parameter 897 can be set by the customer to specify a burner shut-down if the fault is "air shortage".

### 6.6.5.9 Base Value For Inactive O<sub>2</sub> Trim/Insufficient Air

The base values for deactivated O<sub>2</sub> trim and air shortage can be called up by parameter 896.

8 → Correction input ⇔ base value for 'deactivated O<sub>2</sub> trim' parameter 901/902

9 → Correction input ⇔ base value for air shortage parameter 917/918

#### Recommended settings:

for parameters 901/902 and 917/918

Base value for deactivated O<sub>2</sub> trim < neutral value

Base value for air shortage < base value for deactivated O<sub>2</sub> trim.

### NOTICE

The neutral value is obtained from the chosen correction mode:

Correction mode + 50%/-50% → neutral value 500 ⇔ 50%

Correction mode + 60%/-40% → neutral value 600 ⇔ 60%

See chapter 6.7.5 *Correction Modes*

Factory settings:

Parameters 901/902 → base value for 'deactivated O<sub>2</sub> trim' 300

Parameters 917/918 → base value for 'air shortage' 150

This results in the following overall picture (approximate):

## 6 Commissioning

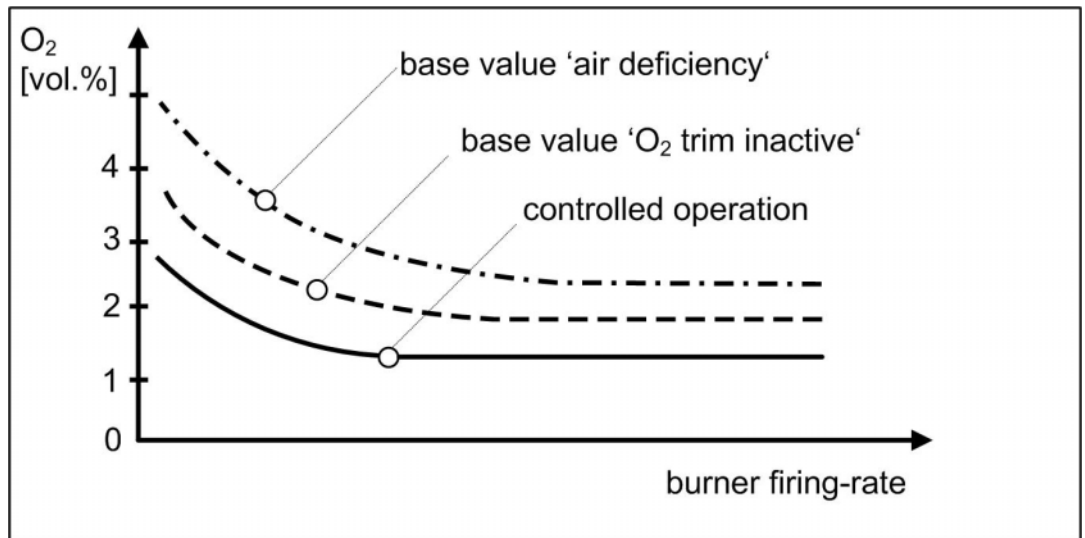

### 6.6.5.10 What Additional Modes mean

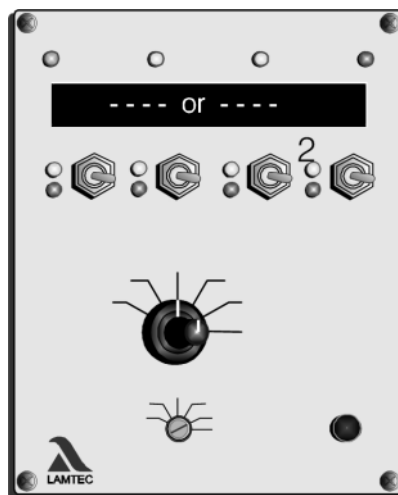

- op O<sub>2</sub> trim on standby (during burner start-up), or O<sub>2</sub> trim temporarily switched off by parameters 914 and 915, depending on firing rate.
- or O<sub>2</sub> trim active
- ot O<sub>2</sub> trim temporarily deactivated (air shortage, probe dynamics etc).
- od O<sub>2</sub> trim deactivated (in fault), e.g. test routines failed during burner start-up, dynamic test negative, O<sub>2</sub> trim temporarily deactivated for over 1 hour etc.

## 6 Commissioning

### 6.6.5.11 How to Reset od



#### Manually:

Turn selector switch to 'O<sub>2</sub> TRIM' mode.  
Press the key ENTER and call up error text.  
Push key 3 (2) upwards



#### WARNING!

Before deleting a fault, it is absolutely necessary to call up the fault text!

#### Automatically:

O<sub>2</sub> faults will be reset automatically at every burner start-up.

### 6.6.5.12 Calling up O<sub>2</sub> Trim Text Messages

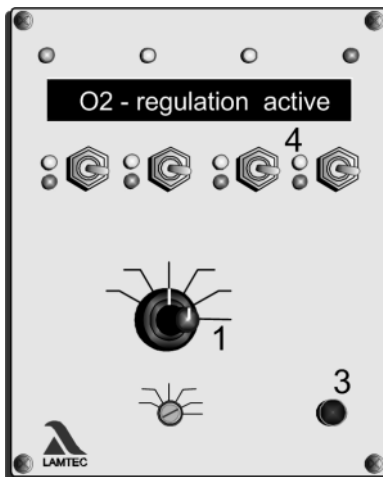

Switch display to O<sub>2</sub>-trim.  
Turn selection switch (1) to STATUS,  
Push channel key 3 (4) upwards

Press the ENTER key (3) to call up the indication.

Back → press ENTER key again (3),  
or turn selection switch (1) to another position.

## 6 Commissioning

### 6.7 Correction

#### 6.7.1 Set Correction Input

Correction signal 1: terminal 27 and 29

Correction signal 2: terminal 33 and 34

The following settings can be set by parameters in service level (level 2)

Current signal:

Current input 1                    0 ... 20 or 4 ... 20 mA

Current input 2                    0 ... 20 or 4 ... 20 mA

#### **NOTICE**

Correction mode and input signal are quoted in the order and are set at the factory. Any change on site is possible only by parameter access at service level (level 2).

#### 6.7.2 CorrectionType1

Correction type 1 is used when correction is applied through a linear control element, e.g. to the frequency converter's setpoint for adjusting the combustion air blower's turning speed.

The correction is directly added to or subtracted from the setpoint.

Correction mode: Affects the setpoint axis

#### Correction of O<sub>2</sub> trim with air actuator

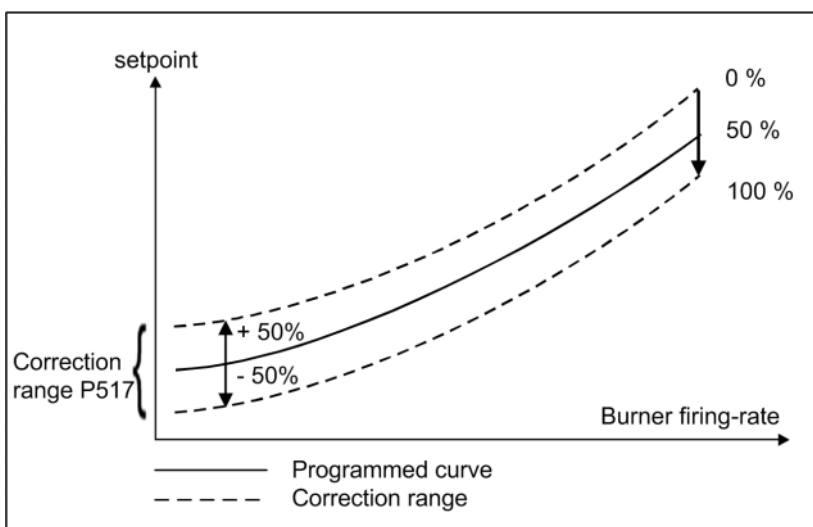

Spread factor = 10  
Increase = 1.0  
Mode +60.....-40  
Input 0%...100%  
Neutral value 60%

## 6 Commissioning

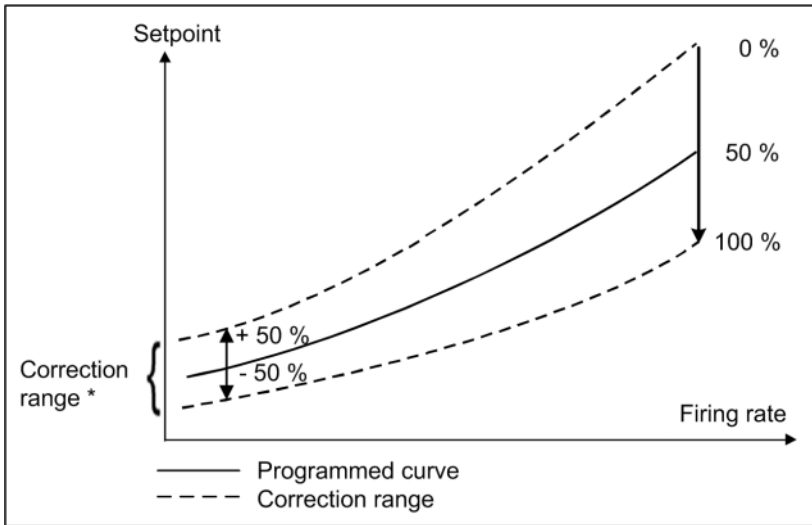

Spread factor > 10  
 Increase > 1.0  
 Mode +60.....-40  
 Input 0%...100%  
 Neutral value 60%

If the correction is applied to a fuel actuator, the effect is reversed so that 0% corresponds to the smallest target value. By using the spread factor held in parameter 433 - Commissioning level - the correction effect can also be weighted across the burner's output.

For details see commissioning manual under Help P 30.

### Correction of CO control with fuel actuator

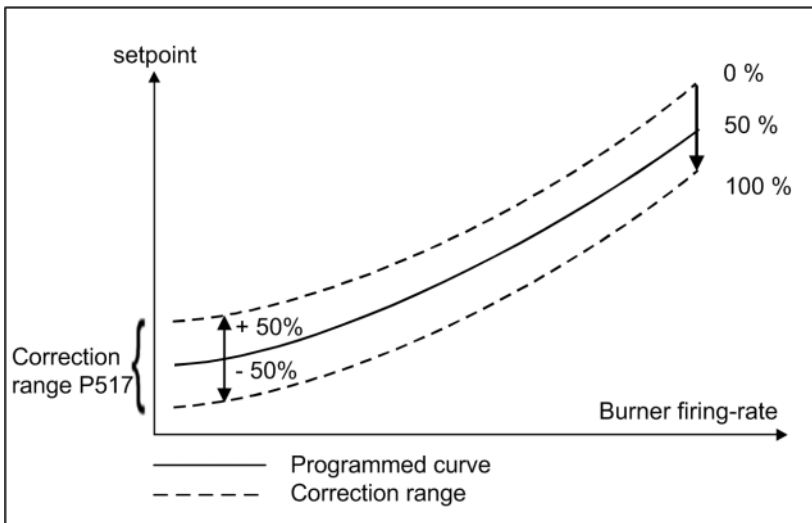

Spread factor = 10  
 Increase = 1.0  
 Mode -50...+50  
 Input 100%...0%  
 Neutral value 50%

## 6 Commissioning

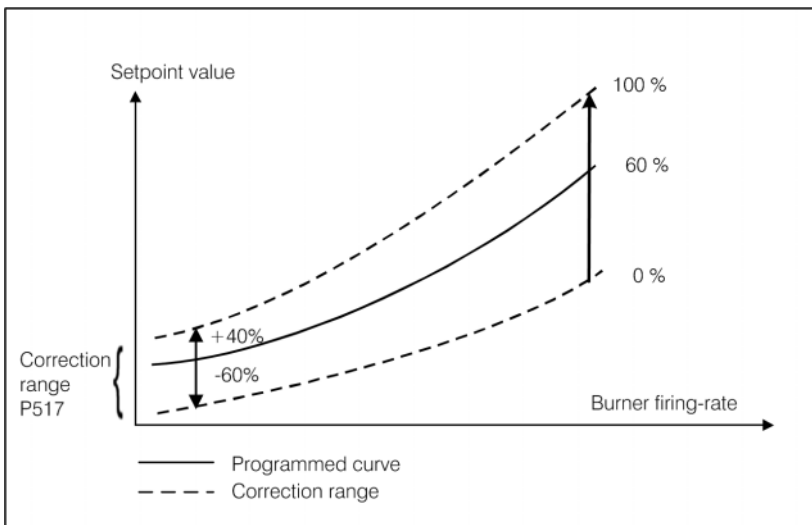

Spread factor > 10  
Increase > 1.0  
Mode -60.....+40  
Input 0%...100%  
Neutral value 60%

### Factory settings:

spread factor 10 1.0, i.e. no weighting

spread factor >10 the correction increases with rising burner output;

spread factor <10 the correction decreases with rising burner output;

### WARNING!

When applying O<sub>2</sub> corrections, make sure that the combustion limits are observed even with the maximum correction applied (100%). For details see chapter, "Checking the combustion engineering limits".

## 6 Commissioning

### 6.7.3 Correction Type 2

#### NOTICE

This is useful only if curve rises continuously!

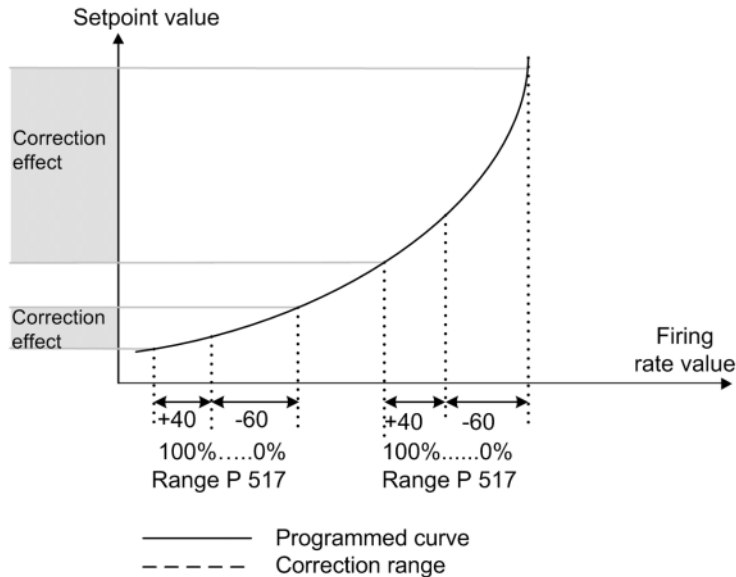

#### WARNING!

Do not use if parts of the curve are horizontal.



#### WARNING!

When applying O<sub>2</sub> corrections, make sure that the combustion limits are observed even with the maximum correction applied (100%).

#### NOTICE

The correction mode indicates how the correction is intended to act. A variety of settings are possible. Figure 1 and 2 show two typical correction modes for O<sub>2</sub> correction.

Type 1 is used where the correction is made on a linear control element, such as a fan frequency converter. The correction is directly added to or subtracted from the setpoint value.

Type 2 is used where the correction is made on a non-linear control element such as an air damper. Before determining the correction, account is taken of the steepness of the curve. A flat curve results in a small correction range, whereas a steep curve give a large range.

If the correction is made to a fuel control element, the effect of the current is reversed, so that 0 mA corresponds to the smallest setpoint.



#### WARNING!

Do not use if parts of the curve are horizontal.

## 6 Commissioning

### 6.7.4 Correctional Range

#### 6.7.4.1 Correction Range Settings

Use parameter 517 to adjust the correction range from 0 to 999.

Example: Ccorrection mode P 437 for O<sub>2</sub> trim is +60/-40  
CO control is +50/-50.  
Correction range P 517 is 100 (digit).

This means:

The adjusting range of the setpoint which can be modified in correction mode should be between +60 (digit) and -40 (digit).

E.g. With a current setpoint of 200 digit, the modifiable by correction adjusting range lies between 260 digit (excess air) and 160 digit (air deficiency).

Recommendation: You should chose the correction mode and the correction range in that way, that the correction effect on the O<sub>2</sub> value is -2 to 3 vol.% O<sub>2</sub>.

#### NOTICE

The correction range (P517) is set to 0 (factory setting) and it must be set during commissioning. Otherwise, it could lead to faults during the probe dynamic test.

#### 6.7.4.2 Calling up the Set Correction Mode

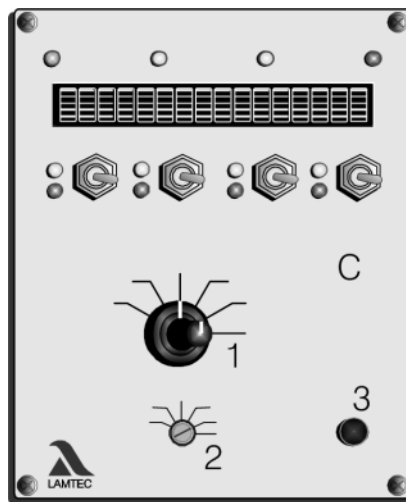

Turn selector switch (1) to STATUS

Press ENTER (3)

→ The display shows the selected correction range

If both correction inputs operate on one channel, the sums are shown (e.g. 15 points).

Press ENTER (3) again, or

Turn selector switch (1) back

→ return to normal display

The correction should be taken into account during later programming. The correction should be able to take effect before the VMS reaches actuator stop.

#### 6.7.4.3 Edit Correction Range

In order to change the correction range, a parameter change must be made. This parameter is accessible through customer access level (level 1).

Proceed as described in parameter settings.

The values for the correction range are saved in parameter P 517 and P 597.

## 6 Commissioning

Examples and illustrations:

### Correction mode + 60 % ... - 40 % (recommended for air correction)

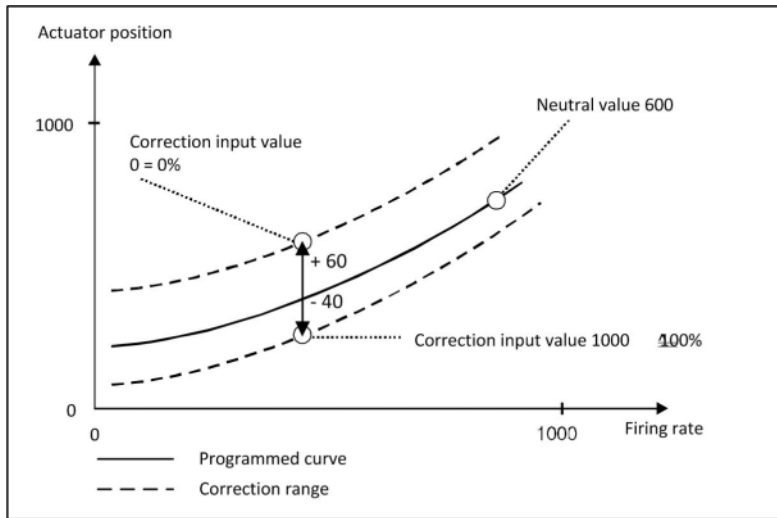

+ 60 % corresponds to correction input value 0  
- 40 % corresponds to correction input value 1000  
Neutral value 600  $\Leftrightarrow$  60%

### Correction mode - 60 % ... +40 % (recommended for fuel correction)

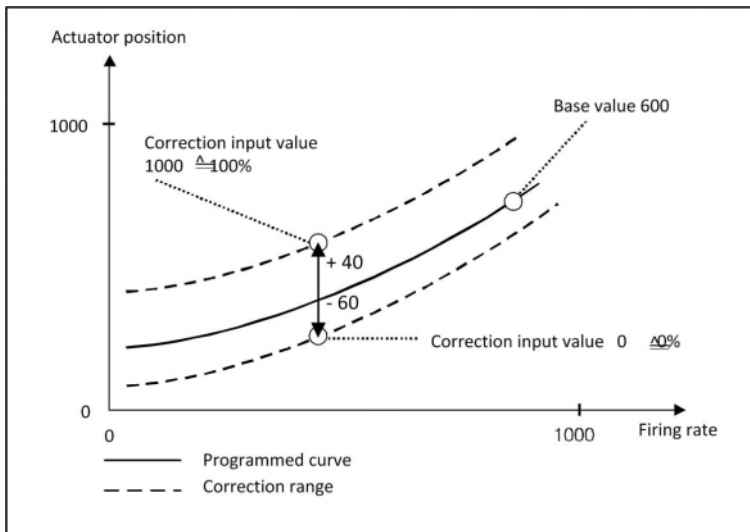

- 40 % corresponds to correction input value 0  
+ 60 % corresponds to correction input value 1000  
Neutral value 400  $\Leftrightarrow$  40%

## 6 Commissioning

### 6.7.5 Correction Modes

---

Correction for air actuator (valve/r.p.m.)		Correction for fuel actuator	
	Base setting		Base setting
+ 50 % ___ - 50 %	50 %	- 50 % ___ + 50 %	50 %
+ 60 % ___ - 40 %	60 %	- 60 % ___ + 40 %	40 %
+ 70 % ___ - 30 %	70 %	- 70 % ___ + 30 %	30 %
+ 80 % ___ - 20 %	80 %	- 80 % ___ + 20 %	20 %
+ 90 % ___ - 10 %	90 %	- 90 % ___ + 10 %	10 %
+100 % ___ - 0 %	100 %	-100 % ___ + 0 %	0 %

## 6 Commissioning

### 6.8 Shut-off Limits

#### 6.8.1 Run to Shut-off Limits

---

The VMS tolerance which was showed by every control system affects the positioning accuracy. These tolerances can be influenced by parameter settings.

When the combustion plant is adjusted, it has to be ensured that the flame burns safe and stable under these tolerances. To verify that, it is necessary not only to check the pre-adjusted setpoints of the fuel/air ratio settings but also to check the so-called shut-off limits. These are the actuator values, which can be taken due to the permitted tolerances but not switch off.

This check is to be done for the whole firing rate range and operating range.

This may only be omitted when:

- the plant is equipped with a failsafe CO or O<sub>2</sub> monitoring, which will automatically off the burner when combustion is incomplete  
or
- the plant is equipped with a failsafe CO or O<sub>2</sub> monitoring, which will compensate the combustion tolerances  
or
- it is ensured that the operating mode will have enough excess air through the whole range and the tolerance of the burner control would be of no consequence.  
or
- the VMS parameters are set in such a way that the tolerances in air deficiency direction has 0 digit, therefore only a tolerance for excess air exists.



#### **WARNING!**

If this shut-off limits check is omitted due to one of these reasons, the efficiency of the measure is to be checked, e.g. check the stability of combustion in the preset shut-off limits in CO/O<sub>2</sub> monitoring.

---



#### **WARNING!**

Due to the evidences required by the authorities and bodies, quality management systems, liability issues, etc, we highly recommend you to document the start-up of this shut-off limits.

---

## 6 Commissioning

### 6.8.2 Check Shut-Off Limits on TPS Output of VMS

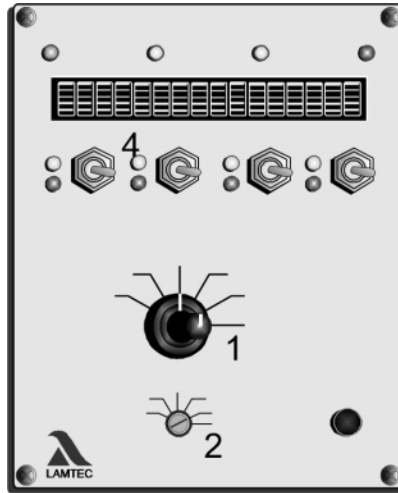

Switch (1) to FIRING RATE

Run to firing rate point to be checked

Wait until the system has run through that point

Switch (2) to SETTING

Adjust setpoint value (4) of the three-point step channel in air deficiency direction (for dead band setting, see parameters 62-76)

Check combustion

Reset setpoint value (4) to original value

In this way run all channels in succession to the limit at the various firing rate points -normally at low, medium and full firing rate.

#### **NOTICE**

Repeat this method for all relevant operating modes (curve sets).

With the adjusted limits towards excess air, it has to be ensured that the flame burns reliably and stably, and also the flame produces no CO from excess air. If this is not ensured, the above described inspection has to be executed towards excess air instead of air deficiency.

## 6 Commissioning

### 6.8.3 Check Shut-Off Limits on VMS Continuous Output

This test is necessary with the use of continuous actuators and with r.p.m. control without the use of CO/O<sub>2</sub> control affecting these r.p.m.

The usage of O<sub>2</sub> trim can be abandoned, if the excess air of deactivated O<sub>2</sub> trim is higher than the setpoint.

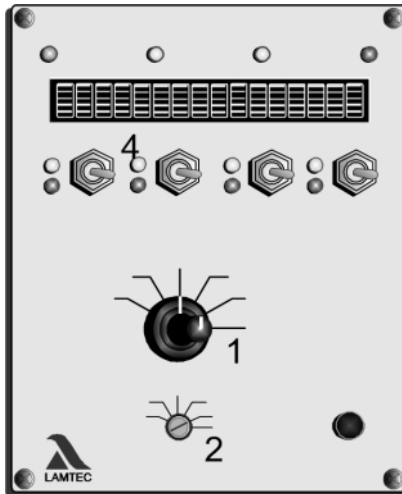

Turn selector switch (1) to FIRING RATE RATING (firing rate)

Run to firing rate point to be checked

Wait until the system has run through that point

Turn selector switch (2) to SETTINGS

Adjust setpoint value (4) of the continuous channel in the air deficiency direction until the actual value feedback has changed by the set number of points (1. monitoring band parameter 62-76)

Check combustion

Reset setpoint value (4) to its origin value

Reset setpoint value (4) to the next continuous channel in air deficiency direction.

Check combustion

Repeat, until all combustions channels are checked at their limits.

#### NOTICE

If a correction affects the continuous channel and if the correction range is bigger than the adjusted monitoring band (what is ordinarily the case), the test can be omitted, Instead of the test, the combustion has to be checked at maximum correctional intervention (see section 2 'Checking the O<sub>2</sub> influence').

The test can also be omitted if the monitoring band is set to 0 at the air deficiency side.



#### WARNING!

With the adjusted limits towards excess air, it has to be ensured that the flame burns reliably and stably, and also the flame produces no CO from excess air. If this is not ensured, the above described inspection has to be executed towards excess air instead of air deficiency.

## 6 Commissioning

### 6.8.4 Checking O<sub>2</sub> Influence

#### NOTICE

If the system is not equipped with an additional O<sub>2</sub>- or CO-monitor, it has to be ensured that the combustion boundary values are kept at maximum adjacent correctional influence.

The correction value can be altered as follows in order to set the correction range and to check the combustion boundary values.

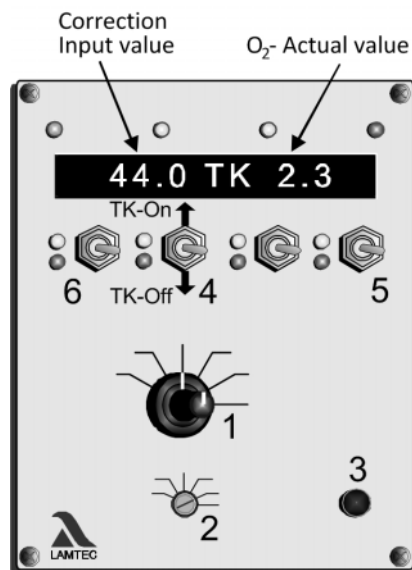

Burner on, controller is enabled (terminal 4).

Turn selector switch (2) to O<sub>2</sub> TRIM

→ Explanatory text is displayed

Press channel key 4 (5) downward

→ Explanatory text disappears

Turn selector switch (1) to FIRING RATE RATING (firing rate)

Press ENTER (3)

→ Correction range is displayed.

With channel key 2 (4) upwards the manual correction is switched on, shown by the display 'TK' in the middle of the display.

The correction value can now be changed with channel key 1 (6), with burner on. The manually selected correction value is maintained until the selector switch (2) is turned to some other position, or normal correction is activated by pressing channel key 2 (4) downward. Adjustment of the correction range is possible by parameter 517 (with the burner in operation). In the event of several fuels (curve sets), the range can also be adjusted individually for each curve set and channel by parameters 517 to 596 (expert level).

To ensure that with deactivated O<sub>2</sub> trim, the tolerance to the air deficiency side is not growing, the parameters 917, 918 and 901, 902 have to be set to the corresponding value. This value depends on the selected correctional mode. Empirical formula (+ correctional mode x 10.)-100.

Example 1:

Correction mode +60/-40 → the parameters have to be smaller than 500, i. e. every value between 0 and 500 creates excess air (600 would correspond to the setpoint curve)

Example 2:

Correction mode +70/-30 → the parameters have to be smaller than 600.

## 6 Commissioning

### 6.8.5 Tolerance Limit in Direction Air Deficiency

---

To be able to perform the test, the parameter values in the air deficiency direction should be known.

 **WARNING!**

If the default setting for dead bands and monitoring bands have changed during commissioning, this must be documented clearly.

---

There is no tolerance in the air deficiency direction if the following parameter setting is retained:

- For fuel channels and recirculation channels - dead band in positive direction parameters 42 to 46 = 0 digits
- For air channels - dead band in negative direction parameters 32 to 36 = 0 digits

Furthermore, the 'band shift in the event of output change' (P 709 to P 712) must have the same value as the monitoring band for the corresponding channel in the air deficiency direction (P 62 to P 76) so that there is no tolerance on the air deficiency side even when there are firing rate changes.

If changes are made to this setting, a documented test of the combustion limit values must be performed, as described previously.

 **WARNING!**

If applicable, the correctness of these parameter settings must be verified. This may be done by checking the parameters on the device or by checking the values via remote software or another suitable analysis tool. We recommend the documentation be done in a form of a protocol. The protocols of the burner settings may contain such a protocol.

---

Note for the example of a protocol on the next side:

With the aid of a protocol, it is possible to document that a check on the switch off limits is not necessary due to the relevant parameter settings. The setting values should be listed in the tables. The numbers are describing the parameter numbers or numbers, on which the settings are based of. The declarations 1 to 6 would be verified with signature.

Cross out everything which are not applicable.

For excess air:

A reason why excess air is not considered must be inscribed. Otherwise, a test of excess air has to be done.



## 7 Tips and Tricks

## 7 Tips and Tricks

### 7.1 Programming 1st Point (Ignition Firing Rate Point)

Programme the first point (ignition firing rate point)

If no separate fuel/air ratio is to be set for the ignition point (selectable via parameter 4 = 0 or 2), proceed as described here.



#### WARNING!

SETTING mode permits direct access to the control elements with the burner running. It is therefore essential to follow the safety rules specified by the burner manufacturer.



#### WARNING!

SETTING mode with the system running must only be undertaken by trained and experienced personnel, whilst keeping a constant watch on the system.

#### NOTICE

The first point entered after clearing the memory is always the ignition firing rate point. This need not be the lowest firing rate point, it is possible to enter ones lower than this. At least 1 point must be entered in order to form a new curve. A subsequent addition up to 20 points is possible at any time, (see chapter 6.5.10 *Adding Points*)

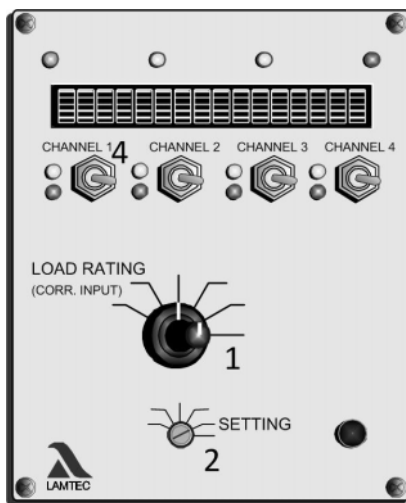

Turn selector switch (2) to SETTING

→ the display shows 'E1' in the middle

Turn selector switch (1) to FIRING RATE RATING (firing rate)

## 7 Tips and Tricks

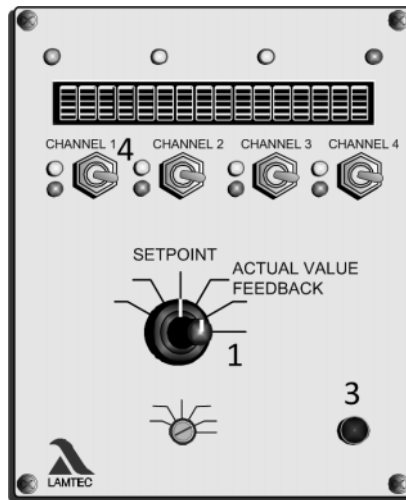

Turn selector switch (1) to SETPOINT

Switch (4) up or down until system is optimally adjusted at ignition firing-rate point

→ control element reacts

→ display changes

Turn selector switch (1) to ACTUAL VALUE FEEDBACK

→ Value of the external feedback (with continuous output) is displayed

→ with three-point step channel the same value as in SETPOINT position is displayed

On VMS 5:

Turn selector switch (1) to DISPLAY CHANNEL 5

→ setpoint and actual value feedback are displayed

Switch (4) (channel 2) up or down until channel 5 is optimally adjusted

→ Wait until feedback has stopped

### 7.2 Programming While The Burner Is Running

Pre-purge has been carried out previously without programmed point.

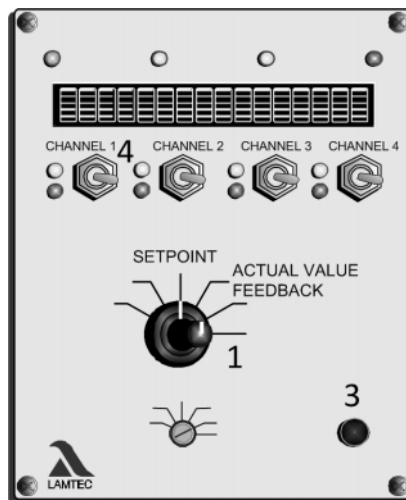

Press ENTER (3).

→ the display shows 'Really ignite?'

Press key (4), to correct the ignition point settings again.

Press ENTER (3) again.

→ Burner ignites

→ The display shows ignition point 1

## 7 Tips and Tricks

### 7.3 Programming While The Burner Is Stationary

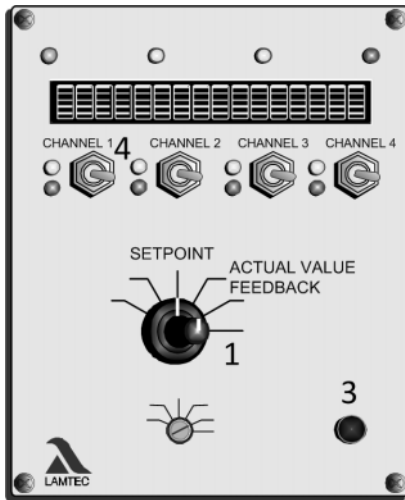

Press the ENTER (3) key.

→ The display shows ignition point 1.

### 7.4 Reversing the Programming

If programming has already started and these values should not be saved, but the old curve should be re-activated instead, then do the following:

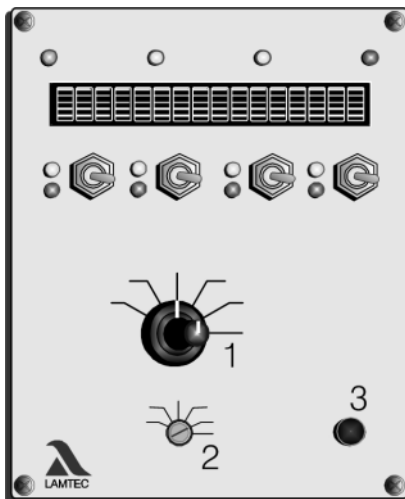

Turn selector switch (2) to CLEAR MEMORY

Turn selector switch (1) to SETPOINT

Press ENTER (3).

→ the display shows 'cleared'

Turn selector switch (2) to AUTOMATIC

→ the old curve is valid

The unit recognises that the RAM does not contain a valid curve that could be transferred to the EEPROM. The last valid EEPROM curve is therefore reactivated.

### 7.5 Commissioning Equipments

When commissioning systems with the VMS it is recommended that several 5k $\Omega$  potentiometers with ready-made connections and at least 2 current transmitters are always carried (particularly where the continuous outputs are used).

The current transmitter should be adjustable in the range 0 ... 20 mA. A voltage range of 0 ... 10 V would also be advantageous in order to be able to simulate the continuous voltage output of the VMS.

In addition 2 multimeters (measuring ranges: current, voltage, resistance) should be available when commissioning.

### 7.6 Adjusting Firing Rate Individually

---

Adjusting firing rate ratings individually when firing rate points are to be adjusted without programming a complete curve.

When adjusting individual points it is normally only possible to freely adjust the setpoint values. This is done by running to the firing rate value (figure appears after the value). The associated setpoint can be adjusted. The figure, which shows that the change is admissible, appears not only right at the programmed firing rate point but also in the range  $\pm 3$  points around this. When stored, however, the value actually displayed is adopted.

At each adjustment of individual points it is therefore possible to shift the firing rate value by up to 6 points.

Procedure for shifting the firing rate value:

Undertake operations as described under "Adjusting individual points" but shift the firing rate rating as required

Set setpoint value

Store

If the desired firing rate rating cannot be achieved in one operation:

Repeat procedure

→ Output point is now the last curve entered

### 7.7 Entering an Initial Curve

---

Since, prior to initial programming, the setpoint EEPROM contains a standard curve that very probably do not correspond to the actual conditions of the system (ranges, setpoint values), the following procedure is recommended for the initial curve:

Make sure that the signal wiring is correct

– see chapter [ExternalLink: Funktionstest](#) and manual

Clear memory

Leave VMS at "Setting"

Have system started up without control release (terminal 4)

After pre-purge, enter ignition firing rate point

Ignition

Give control release (terminal 4)

Enter further points with burner running

Store

### 7.8 Approaching Control Elements From One Side

---

If there is an overshoot, the fuel/air ratio control would drive to the actuator from one side during the operation, to compensate for the mechanical hysteresis of the valves. All the setpoints would be driven from above.

Exception:

The highest point is never overrun and therefore driven from below.

When it comes to setting, it is to be ensured that the valves are driven in the same way. As a result the system values are reproduced in exactly the same way in automatic mode .

## 7 Tips and Tricks

### 7.9 Enter Set Point Values

---

Selector switch (2) to "Setting"  
Run to desired setpoint from above  
if accidentally running below this point  
Run above setpoint and re-approach from above

### 7.10 Entering the Highest Setpoint

---

Selector switch (2) to "Setting"  
Run to desired setpoint from below  
If accidentally running below this point → Run below setpoint and re-approach from below

#### **NOTICE**

Only in this way will you reach the same valve position and hence also the same combustion values in setting as later during automatic operation.

---

### 7.11 Start Without Pre-Purge

---

Even if the installation is to be started without pre-purge, the pre-purge signal (terminal 3) must be given for at least 3 seconds so that the VMS progresses one sequence and approaches the ignition point. Pre-purge need only be continued to the end, i.e., with the channels running to their end position, if the pre-purge signal is present for more than 10 seconds. If the pre-purge signal is removed before all actuators are up, this is ignored and the actuators still move to the topmost limit stop.

### 7.12 Ignition Delay During Adjustment

---

When the ignition point is entered for the first time, it is possible to observe the ignition process by entering a delay time.  
To do this, the time needed to run to the burner sight glass and to the boiler end respectively must be set in parameter 759. As soon as the question 'Really ignite?' is confirmed by pressing the ENTER key, the time expires.  
After this sequence, the ignition is released.  
This time operates only if the VMS is on SETTING mode.

### 7.13 Set Firing Rate Automatically

---

Parameter 4 is used not only to select the separate ignition point but also to determine whether the regular firing rate input is to be automatically pre-set during setting.  
If this is the case, the firing rate points (in addition to the ignition point) are fixed at the values 200 (corresponding to 4 mA at the firing-rate input), 250, 300, 400, 500, 600, 700, 800, 900 and 999.  
It is then possible to switch only between these points by using the FIRING RATE switch position. You cannot run to intermediate values during SETTING.  
Storing a point causes the firing-rate default to skip to the next value (unless this is already taken up). In this way a curve can be entered without shifting to FIRING RATE.

### 7.14 Entering the Fuel/Air Ratio Control With The Burner Stationary

---

Disconnect 'Burner On' signal (terminal 2) so that burner does not start  
Control the fan manually (e.g. Bridge terminal 81 and terminal 89 on relay R16)

 **CAUTION!**

**Danger of electrical shock!**  
**As a result, terminal 92 also receives a voltage**

---

Enter curve.

Remove manual activation of the fan (e.g. remove bridge terminal 81 and terminal 89 on relay R16).

Re-connect 'Burner On' signal (terminal 2) again.

### 7.15 Recirculation Damper Closed During Pre-purge

---

The pre-purge behaviour of the re-circulation duct according to the technical regulations on steel boilers [TRD] is incorporated into the software of the VMS. That is, the re-circulation dampers always open with a delay. If the system subsequently requires the re-circulation to remain closed during pre-purge, this can be achieved by means of the pre-purge limit parameters (parameter 346-350).

**Clear range limits:**

Switch (2) to CLEAR MEMORY

Press ENTER.

Switch (2) to AUTOMATIC

Select pre-purge limit parameter for the re-circulation duct

Enter CLOSE position of the re-circulation damper

Have range limits re-entered through pre-purge

→ Now the re-circulation damper does not open during pre-purge.

### 7.16 Switching the Burner On Again Through the Setpoint

---

If the integral output controller is used and a negative value is entered in parameter 802, it is possible to achieve a situation where the burner is switched on accordingly through the setpoint.

### 8 System Operation

#### 8.1 Mode Display

##### 8.1.1 Mode Abbreviations Used

---

ON	→	SWITCH-ON SEQUENCE
BE	→	READY
ZÜ	→	IGNITION POSITION
EZ	→	SETTING/IGNITION
GL	→	BASE FIRING RATE
EG	→	SETTING/BASE FIRING RATE
NA	→	POST-PURGE
AU	→	OFF
EI	→	SETTING
SL	→	CLEAR MEMORY
EV	→	SETTING/PRE-PURGE
ES	→	SETTING/CONTROL
ST	→	FAULT
VO	→	PRE-PURGE
HA or HAND	→	MANUAL MODE
LE	→	FIRING-RATE EXTERN
no indication	→	CONTROL MODE

BE indicates that the signal is present on terminal 2, and all other signals = 0  
If the VMS controls a flue gas damper, it opens. It is possible to switch to SETTINGS.

ZÜ indicates that pre-purge is finished and the ignition position relay pulls on. The VMS is in the ignition position, but the flame signal is absent.  
EZ Switching to SETTING merely causes the mode display to switch to EZ. Programming is not possible in this mode.

GL indicates that the burner is on (terminal 8=1), but the control release is absent (terminal 4=0). The VMS therefore remains in base firing rate position. Switching to SETTING merely causes the mode display to switch to EG. Programming is not possible in this mode.

NA indicates that the VMS is in post-purge mode.  
All signals = 0  
All air channels open. When the configured time has elapsed, the VMS changes to AU mode.

AU indicates that the VMS is OFF. All control elements closed.  
Selector switch on AUTOMATIC, all signals = 0

EI indicates that the mode selector switch is on SETING. Single points can now be altered or new curves can be entered.

SL indicates that the mode selector switch is set to CLEAR MEMORY. By pressing the ENTER key the existing curve is cleared and a new curve can be entered.

## 8 System Operation

EV	indicates that although the mode selector switch is on SETTING it is nevertheless performing the pre-purge routine. There is a signal on terminal 3. If the selector switch is on SETTING and there is a 'signal on terminal 3', nevertheless the VMS maintains its control function. The setting mode (display 'EI') is only activated when the pre-purge is completed and there is a flame signal and control release. Therefore the VMS can only be programmed, when the signal combination corresponds either to the AU and/or 'BE' mode, or when the signal combination corresponds to the AUTOMATIC mode.
ES	indicates that although the mode selector switch is on SETTING. It's control function is working according to a calculated curve in the RAM. The curve is calculated from a partial curve, which is already entered. This mode is reached if the burner is switched off and is restarted during a programming sequence. The programming can be continued by operating a switch (change to 'EI' mode). Flame signal and control release are present.
ST	indicates that the VMS is set to FAULT. The fault code can be called up in switch position STATUS. In the switch position FIRING RATE the firing-rate at the time when the fault occurs, is displayed.
VO	indicates that the VMS is in PRE-PURGE mode. There is a signal on terminal 2 and a signal on terminal 3. Pre-purge routine is active.
HAND or HA	indicates that the VMS has been switched to manual mode whilst the burner is running. In the selector switch position FIRING RATE the firing-rate can be adjusted by actuating the channel 1 switch. To quit manual mode, actuate any switch but the channel 1 switch.
ext.Hand	indicates that the VMS was switched to manual operation, but the firing-rate was specified externally and not via the channel 1 key (that is, e.g. via remote software or bus).
LE	indicates that the output controller of the VMS is deactivated and the firing rate is controlled by an external signal

### 8.1.2 O<sub>2</sub> Trim Modes

---

op	O <sub>2</sub> controller on standby (at startup burner), or O <sub>2</sub> controller temporarily switched off as a function of firing rate via parameters 914 and 915.
or	O <sub>2</sub> controller active
ot	O <sub>2</sub> controller temporarily deactivated (air shortage, probe dynamics, etc)
od	O <sub>2</sub> controller deactivated (during fault) e.g. test routines failed during burner startup, dynamic test negative, O <sub>2</sub> controller temporarily deactivated for longer than 1 hour, etc.

### 8.1.3 ES Mode (Set - Control)

---

Should the burner skip to ES mode while programming is in progress:

## 8 System Operation

### NOTICE

This mode allows the electronic fuel/air ratio control to run within curve sections already entered and thereby facilitates setting.

If the firing rate drops by 40 points, the VMS skips to ES mode, thereby controlling the outputs automatically.

ES mode is also started if the switch 1 is set to FIRING RATE and the channel 2 switch is pushed up.

---

Back to normal programming

Tap on a switch → the VMS changes to EI mode

Continue programming in the usual way

### 8.1.4 Proceed with Programming

---

If the burner is omitted due to control shutoff, proceed as follows:

Undertake no further action on the VMS

Wait until the boiler temperature has fallen

Allow burner to start normally

Pre-purge.

→ the display shows EV

→ VMS control the outputs according to the pre-purge

Burner ignites

→ ES appears on the display

→ VMS controls the output according to the entered sub curve

### NOTICE

The highest firing rate already entered would not be exceeded.



### WARNING!

For your safety:

ES mode should be run only by trained personnel with the system under constant supervision.

---

Run to next firing-rate to be programmed

Push switch up

→ VMS switch back to EL mode

continue programming at the point where the burner cut-out previously occurred

### NOTICE

Should the mains voltage to the Gerät has failed (display dark, operating LEDs out), before switching back to AUTOMATIC, all curve points already entered will have been lost. Start programming from beginning again.

---

## 8 System Operation

### 8.2 Check Sums - Hours of Operation

#### 8.2.1 Calling the Checksums

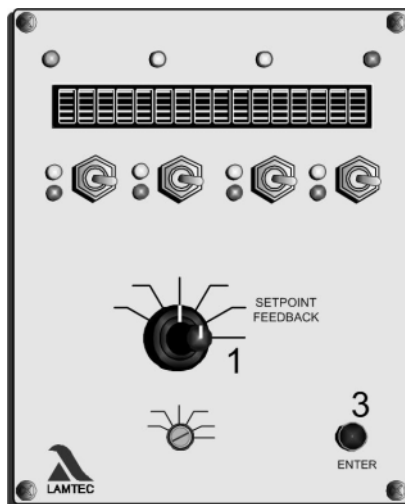

Switch (1) to SETPOINT FEEDBACK

Press ENTER (3) and keep pressed

- the display shows the checksum and the safety times one after the other.

Each of the parameter levels is safeguarded by its own checksum. The checksum for each level and the safety and pre-purge times are displayed here in succession.

Order:

- |              |   |
|--------------|---|
| CRC 16 level | 0: adjustable without password                                      |
|              | 1: adjustable by person commissioning                               |
|              | 2: adjustable by the burner manufacturer or the boiler manufacturer |
|              | 3: adjustable by LAMTEC only  |
|              | 4: adjustable by LAMTEC only  |

1<sup>st</sup> oil safety time in seconds

2<sup>nd</sup> oil safety time in seconds

1<sup>st</sup> gas safety time in seconds

2<sup>nd</sup> gas safety time in seconds

Pre-purge time in seconds

On the VMS without pilot burner the statement of the 2<sup>nd</sup> safety time contains safety time. The statement of the 1<sup>st</sup> safety time is then irrelevant.

#### **NOTICE**

If the parameter has been changed, the checksum will change, too, if a total reboot has been proceeded or the duration of 1h has passed.

## 8 System Operation

### 8.2.2 Calling up the Hour Counter

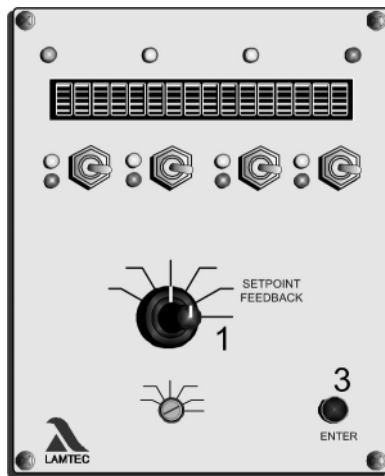

Turn selector switch (1) to SETPOINT

→ the display shows a moving text with the following content:

- total running hours
- running hours on curve set 1
- starts on curve set 1
- running hours on curve set 2
- starts on curve set 2

If you use the 4 curve set or 8 curve set option the display shows the running hours and starts on the additional curve sets.

#### NOTICE

The sum of the curve set 1 running hours and curve set 2 running hours does not necessarily give the running hours value, which is displayed in total. The total counter relates to the VMS running hours. It runs as soon as the unit is connected to a power supply (this also provides the basis for the fault history).

The single running time meters relate to the burner running hours. These run as soon as the burner is in operation with the respective curve set (flame signal to the VMS).

## 8 System Operation

### 8.3 Messages / Faults

#### 8.3.1 What Happens if There is a Fault?

---

##### **NOTICE**

If the processor detects a fault, it runs the outputs in the programmed direction, e.g. air on, fuel off, re-circulation closed.

The fuel solenoid valves close. The fault signal relay pulls on with a few seconds delay. Automatic restarting may be possible, depending on the nature of the fault.

---

#### 8.3.2 Reading Faults

---

Red LED fault lights up

Switch (1) to STATUS

→ Fault code is displayed

Note code and firing rate values (external and internal).

Press Enter (3)

→ The display shows plain text message including running time meter reading up to the time of the fault

A list of the fault codes, error texts and help can be found in the document "Commissioning Supplement List of Fault Codes for FMS/VMS/ETAMATIC/ETAMATIC OEM/FA1" (Publication no. DLT1050).

#### 8.3.3 Resetting Faults

---

Switch to STATUS.

Left-hand switch up

→ the fault is cleared unless the cause is still directly present.

Alternative:

VMS: Set signal on terminal 3 briefly (min. 2 seconds) via external switch.

→ Fault is cleared!

### 8.3.4 Recalling Fault History

#### NOTICE

The VMS stores the last 10 faults with the associated running time meter values



Turn selector switch (1) to STATUS

→ the display shows the actual status

Channel 1 switch (4) up

→ the display shows the latest fault code and the firing rate values from the moment when the fault occurs

Press ENTER (3)

→ the display shows text and running time meter reading

Channel 1 switch (4) up again

→ the display shows the last but one fault code and the firing rate values from the moment when the fault occurs

Press ENTER (3)

→ the display shows the fault code and the related operating mode.

You can browse through the fault history by pressing the channel 1 switch

#### NOTICE

If it is assured that the VMS has been set on power since the last fault, the time of the fault can be determined with the help of the current running time meter reading and the current time.

### 8.3.5 What Happens if a Fault Occurs in the O<sub>2</sub> Controller?

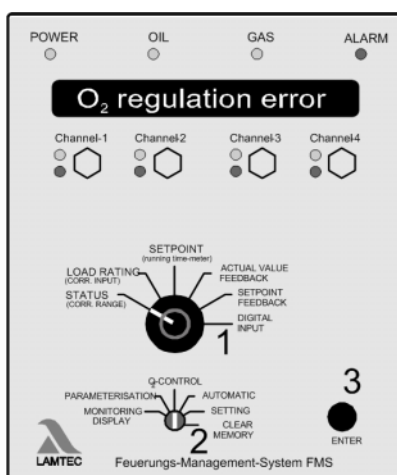

In the event of a fault, the display shows a warning message and the O<sub>2</sub> controller is deactivated.

The specified base value 'Without control' or the one for 'Air shortage' is set.

The display shows the running text 'O<sub>2</sub> trim at fault'.

The burner would not be shut down.

Turn selector switch to STATUS to call up the corresponding error code.

The display shows a plain text message about the cause of error after you pressed the ENTER key (3).

## 8 System Operation

### 8.3.6 Air Deficiency Failure

If the O<sub>2</sub> actual value is significantly smaller than the O<sub>2</sub> setpoint value (below the second monitoring band) and corrective actions by the VMS cannot clear this error, then the trim is deactivated and the base value for air deficiency errors will be put out.

At air deficiency, the VMS triggers an air deficiency burner shut-down. Therefore set P 897 to 1.

The error code is H360, "Error shut-down by O<sub>2</sub> trim".

### 8.3.7 Resetting O<sub>2</sub> Errors

O<sub>2</sub> errors are automatically reset with each new burner start-up. This is permissible, since a 100 % O<sub>2</sub> measurement test is performed at each start-up.

Manual resetting of O<sub>2</sub> errors is possible at any time, as follows:

Switch (1) to STATUS

→ VMS in O<sub>2</sub> trim mode?

If not, switch over to O<sub>2</sub> trim mode by pushing channel key 3 (4) upwards

Press the ENTER key (3) and call up the cause of error (mandatory!)

Push key 3 (4) upwards

### 8.3.8 Calling Fault History O<sub>2</sub> trim

Switch over to VMS / Fuel/Air Ratio Control System mode (controller of fuel/air ratio control).

Turn selector switch (1) to STATUS

Switch channel 3 down

→ You can browse through the fault history with channel key 2



1 ↑ current fault	147 ↑ internal firing-rate	1 ↑ curve set	000 487 ↑ operating hours
-------------------------	----------------------------------	---------------------	---------------------------------

The display of O<sub>2</sub> history disappears automatically after 5 sec.

O<sub>2</sub> controller faults lasting over 30 sec. are stored. They are only stored in the EEPROM, once the fault is cleared or the VMS leaves the operating modes 'Controller' or 'Base firing rate'.

## 8 System Operation

### 8.3.9 Fault Codes

Fault Code No.	Restart according to		Description
	TRD	EN676	
000	0	0	<b>No fault code available for this fault</b>
001	0	3	<b>Ignition flame does not appear.</b>
H/Ü			Check flame stability. Check wiring. Check ignition transformer and pilot burner. Check flame sensor. Check Parameter 788.
002	0	0	<b>parasitic light failure</b>
H/Ü			Check wiring. Check setting flame sensor. Check Parameter 788.
003	0	3	<b>Flame fault during ignition</b>
H/Ü			Check flame stability. Check ignition transformer and pilot burner Check flame sensor settings
004	1	1	<b>Flame fault during operation</b>
H/Ü			Check flame stability The switch off time for digital input "flame signal is <200ms! For this reason, a flame fault can also have another cause, e.g.: - The fuel solenoid valves close.(EMV, low voltage)) - "gas pressure < min" switch off time <1s  FMS with 660 R 0016 V4.3 with burner stationary Check wiring between FMS and 660R0016 V4.3 Change 660 R 0016 V4.3 if wiring is correct.
005	0	3	<b>Flame signal does not appear during 1st safety time</b>
H/Ü			Check flame stability. Check wiring. Check ignition transformer and pilot burner. Check flame sensor. Check Parameter 774, 775 and 788.
006	0	3	<b>Flame signal goes out during stabilising time</b>
H/Ü			Check flame stability. Check set pilot burner. Check flame sensor.
007	0	3	<b>The flame signal extinguishes during the first safety time</b>
H/Ü			Check flame stability. Check set pilot burner. Check flame sensor. ETAMATIC: Check Jumper.
008	0	0	<b>The flame signal extinguishes during the second safety time</b>
H/Ü			Check flame stability. Check wiring. Check flame sensor.

## 8 System Operation

Fault Code No.	Restart according to		Description
	TRD	EN676	
<b>009</b>	<b>0</b>	<b>0</b>	<b>Flame signal does not appear during safety time</b>
H/Ü			Check flame stability. Check wiring. Check flame sensor. Check Parameter 774, 775 and 788.
<b>010</b>	<b>0</b>	<b>0</b>	<b>Flame signal goes out immediately after ignition</b>
H/Ü			If the flame extinguishes within three seconds after ignition, fault H010 is shown; after that, fault H004 appears. Check the flame stability. Check the flame sensor setting. Check the sensitivity of the sensor. The deactivation time for the "Flame signal" digital input amounts to <200ms! For this reason, a flame fault can also have another cause, e.g.: - The solenoid fuel valve closes (EMC, low voltage) - "Gas pressure < min" deactivation time <1s.
<b>011</b>	<b>0</b>	<b>0</b>	<b>Internal fault: 5 sec. outside light monitoring period not kept</b>
			The fault can occur during an internal self-test. Reset the fault. In the process, switch the mains voltage off and on again if necessary. Check all fuses in the device. If the fault persists despite reset → exchange the device or respective card
<b>012</b>	<b>0</b>	<b>0</b>	<b>relay module not connected or missing 24V supply for relay</b>
			Check the wiring between FMS and relay module 660R0016 and fuse F2 on the FMS front panel. FMS with relay module type 660 R 0016 V4.3 when the burner is at a standstill: Check the wiring between FMS and 660 R 0016 V4.3. If the wiring has been performed correctly: Exchange relay module type 660 R 0016 V4.3.
<b>013</b>	<b>1</b>	<b>3</b>	<b>main flame signals appears during ignition</b>
			If parameters 774 and 775 are set to value 3 or 4, only the ignition flame may be present during ignition (up to the beginning of the second safety time). If the main flame is detected in this time, fault S013 is displayed. Check the flame sensor setting. The main flame sensor must detect only the main flame and not the ignition flame.
<b>102</b>	<b>0</b>	<b>0</b>	<b>Internal fault: Internal communication fifo has overflowed</b>
H			The fault can occur during an internal self-test. Reset the fault. In the process, switch the mains voltage off and on again if necessary. Check all fuses in the device. If the fault persists despite reset → exchange the device or respective card.

## 8 System Operation

Fault Code No.	Restart according to		Description
	TRD	EN676	
<b>103</b>	<b>0</b>	<b>0</b>	<b>Internal fault: Error in misc. data</b>
H/Ü			<p>The fault can occur during an internal self-test. A fault was discovered during the reading of the redundant data in the EEPROM.</p> <p>Reset the fault. In the process, switch the mains voltage off and on again if necessary.</p> <p>Check all fuses in the device.</p> <p>Re-enter the curve.</p> <p>Import the current data record into the device using the remote control software and check this data record.</p> <p>If the fault persists despite reset → the EEPROM is possibly defective: Exchange the EEPROM.</p> <p>Import the current data record into the device using the remote control software and check this data record.</p>
<b>104</b>	<b>0</b>	<b>0</b>	<b>Internal Fault: D/A-Converter faulty</b>
H			<p>Fault during an internal self-test.</p> <p>Reset the fault; switch the mains voltage off and on again if necessary.</p> <p>Check all fuses in the device.</p> <p>If the fault message continues to persist →exchange the device or respective card.</p>

## 8 System Operation

Fault Code No.	Restart according to		Description
	TRD	EN676	
<b>105</b>	<b>&gt;88</b>	<b>3</b>	<b>Curve data faulty! Curve set no.:</b>
H/Ü			<p>During an attempt to save the curve to the EEPROM / during the check of the redundant curves, a fault was discovered. Repeat the programming. Reset the fault. If this fault is still present, proceed as follows:</p> <p>If this fault occurs after the number of curves has been expanded:</p> <ol style="list-style-type: none"> <li>1. Select the corresponding curve set</li> <li>2. Delete the memory</li> <li>3. Program a new point</li> </ol> <p>If the data was saved using the remote control software: Import the curve data of the corresponding curve set into the device. If this is not possible:</p> <ol style="list-style-type: none"> <li>1. Select the corresponding curve set</li> <li>2. Delete the memory</li> <li>3. Re-enter the curve</li> </ol> <p>Reset the fault. If the fault persists → the EEPROM might be defective. Order a new EEPROM from LAMTEC. When ordering, enter the original purchase order number, sales order number, and commission of the device. Return the defective EEPROM in any case (for the address, see the overleaf of this publication). Exchange the EEPROM and import the current data record into the device using the remote control software and check the result.</p> <p>When exchanging this component, a basic setting must exist before you can continue to work with the device. If you have saved the data of the device using the remote control software, it suffices to reimport this saved data into the new EEPROM. For more details, see the "Protected data record" description in the remote control software. If this is not possible, you must order a preprogrammed EEPROM from LAMTEC.</p> <p>When ordering, you must enter the device number and software checksums. Only in this way are mix-ups excluded. For the address, see the overleaf of this publication.</p>
<b>106</b>	<b>0</b>	<b>0</b>	<b>parameters not equal for parameter no.:</b>
Ü			<p>Fault during an internal self-test. A fault was discovered during the reading of the redundant data in the EEPROM.</p> <p>After a software update: Import the protected data recording into the device. If that is not possible: Change the reported parameters once manually. Reset the fault.</p> <p>Reset the fault; switch the mains voltage off and on again if pertinent. Re-enter the curve. If the fault persists → the EEPROM is possibly defective: Exchange the EEPROM, import the current data record into the device using the remote control software, and check the data record.</p>

## 8 System Operation

Fault Code No.	Restart according to		Description
	TRD	EN676	
<b>107</b>	<b>0</b>	<b>0</b>	<b>Invalid configuration</b>
H/Ü			<p>Fault during an internal self-test. Reset the fault; switch the mains voltage off and on again if necessary. Using the remote control software, compare the current parameter setting and last working data record.</p>
<b>108</b>	<b>0</b>	<b>0</b>	<b>Different input signals on main processor and monitoring processor terminal-</b>
H			<p>Fault during an internal self-test. The digital input signals for the main processor (H) and monitoring processor (Ü) are compared and are not the same. Reset the fault; switch the mains voltage off and on again if pertinent. Check all fuses in the device.</p> <p>A bouncing signal can lead to different states being detected between the main and monitoring processors. In the case of the main and monitoring processors, the detection of the digital input signals takes place at slightly different times. A signal change is present only long enough for the main processor to detect it, but not the monitoring processor. Check the signal sequence.</p> <p>If fault messages are constantly appearing one after the other → exchange the device or the respective card (processor card).</p>
<b>110</b>	<b>0</b>	<b>0</b>	<b>CRC-16 test had found an error</b>
H/Ü			<p>Fault during an internal self-test. Reset the fault; switch the mains voltage off and on again if necessary. Check all fuses in the device. If the display remains dark or shows confusing characters, some or all of the LEDs will light up and faults 111 and 140 will appear.</p> <p>After the exchange of an EPROM or RAM: - Remove the processor pc board Check the components for the correct polarity (all notches point in the same direction). Check whether all components are properly inserted (e.g., whether any prongs are bent), and press them in firmly if necessary. Check the proper seat of the processor card connection to the backplane. Check the proper seat of the power supply card connection to the backplane.</p> <p>If fault messages are constantly appearing one after the other → the EPROM programme is possibly defective. Request a new programme EPROM from LAMTEC with the precise specification of the respective purchase order number, sales order number, and commission of the device. Return the defective EPROM in any case (for the address, see the overleaf of this publication).</p>

## 8 System Operation

Fault Code No.	Restart according to		Description
	TRD	EN676	
<b>111</b>	<b>0</b>	<b>0</b>	<b>RAM-Test detected error</b>
H/Ü			<p>Fault during an internal self-test. Reset the fault; switch the mains voltage off and on again if necessary. Check all fuses in the device. Check the curve points of the main and monitoring processors for irregularities. → Remote software: Curve table and/or set value graphic. If the display remains dark or shows confusing characters, some or all of the LEDs will light up and faults 111 and 140 will appear.</p> <p>After the exchange of an EPROM or RAM: - Remove the processor pc board Check the components for the correct polarity (all notches point in the same direction). Check whether all components are properly inserted (e.g., whether any prongs are bent), and press them in firmly if necessary. Check the proper seat of the processor card connection to the backplane. Check the proper seat of the power supply card connection to the backplane.</p> <p>If the fault occurs only sporadically, a software update to at least Version 5.7 may help.</p> <p>If fault messages are constantly appearing one after the other → exchange the device or the respective card.</p>
<b>112</b>	<b>0</b>	<b>0</b>	<b>ETAMATICselftest exceeds timeout limit</b>
			<p>Fault during an internal self-test. Reset the fault; switch the mains voltage off and on again if necessary. Check all fuses in the device. If fault messages are constantly appearing one after the other → exchange the device or respective card.</p>
<b>120</b>	<b>1</b>	<b>1</b>	<b>Different operating modes for mon. and main processor</b>
H/Ü			<p>Fault during an internal self-test. Reset the fault; switch the mains voltage off and on again if necessary.</p> <p>In the case of the main and monitoring processors, the detection of the digital input signals takes place at slightly different times. A signal change is present only long enough for the main processor to detect it, but not the monitoring processor. Check the signal sequence.</p>
<b>121</b>	<b>0</b>	<b>0</b>	<b>The correction is outside the permissible range. Channel: 1</b>
Ü			<p>The monitoring processor checks whether the current correction values lie within the set range. Check the correction range. If fault messages are constantly appearing one after the other → exchange the device or respective card.</p>
<b>122</b>	<b>0</b>	<b>0</b>	<b>Correction is outside permissible range. Channel : 2</b>
Ü			See S121
<b>123</b>	<b>0</b>	<b>0</b>	<b>Correction is outside permissible range. Channel : 3</b>
Ü			See S121
<b>124</b>	<b>0</b>	<b>0</b>	<b>Correction is outside permissible range. Channel : 4</b>
Ü			See S121
<b>125</b>	<b>0</b>	<b>0</b>	<b>Correction is outside permissible range. Channel : 5</b>
Ü			See S121

## 8 System Operation

Fault Code No.	Restart according to		Description
	TRD	EN676	
139	0	0	<b>Integr. Flame Detector: selftest fault</b>
H/Ü			<p>Especially in the case of oil flames: Reduce the intensity of the flame sensor.</p> <p>Check the hardware and software configuration: If the hardware jumper is set to external flame monitoring and parameter 2 is set to integrated flame monitoring, fault 139 appears as soon as the digital input of the external flame monitoring becomes active. If the flame signal is detected via the flame sensor of the integrated flame monitoring in this configuration, the display of the digital input cycles and a flame fault appears.</p>
140	0	0	<b>The EEPROM is defective.</b>
H/Ü			<p>Fault during an internal self-test. Reset the fault; switch the mains voltage off and on again if necessary. Check all fuses in the device. If the display remains dark or shows confusing characters, some or all of the LEDs will light up and faults 111 and 140 will appear. The EEPROM of the respective processors contains important operating data, the parameters, and the curves. During an attempt to save the curve to the EEPROM, a fault was discovered. Repeat the programming. After the exchange of an EPROM or RAM: Remove the processor pc board Check the components for the correct polarity (all notches point in the same direction). Check whether all components are properly inserted (e.g., whether any prongs are bent), and press them in firmly if necessary. Check the proper seat of the processor card connection to the backplane. Check the proper seat of the power supply card connection to the backplane. Reset the fault if it is still present; the EEPROM is possibly defective. Request a new EEPROM from LAMTEC with the precise specification of the respective purchase order number, sales order number, and commission of the device. Return the defective EEPROM in any case (for the address, see the overleaf of this publication). Exchange the EEPROM, import the current data record into the device using the remote control software, and check the data record. When exchanging this component, a basic setting must exist before you can continue to work with the device. If you have saved the data of the device using the remote control software, it suffices to reimport this saved data into the new EEPROM. For more details, see the "Protected data record" description in the remote control software. If this is not possible, you must order a preprogrammed EEPROM from LAMTEC. When ordering, you must enter the device number and software checksums. Only in this way are mix-ups excluded. For the address, see the overleaf of this publication.</p>

## 8 System Operation

Fault Code No.	Restart according to		Description
	TRD	EN676	
<b>141</b>	<b>0</b>	<b>0</b>	<b>Potentiometer faulty, feedback changing too quickly: channel 1</b>
H/Ü			The return values of a three-point-step servo output change faster than specified as maximum in parameters 12-16. Check the wiring; check the potentiometers for short circuit. It is possible that the range limit switch is set higher than the end of the range of the potentiometer. The upper value is exceeded and changes quickly towards zero. Otherwise, exchange the potentiometers.
<b>142</b>	<b>0</b>	<b>0</b>	<b>Potentiometer faulty, feedback changing too quickly: channel 2</b>
H/Ü			See S141
<b>143</b>	<b>0</b>	<b>0</b>	<b>Potentiometer faulty, feedback changing too quickly: channel 3</b>
H/Ü			See S141
<b>144</b>	<b>0</b>	<b>0</b>	<b>Potentiometer faulty, feedback changing too quickly: channel 4</b>
H/Ü			See S141
<b>145</b>	<b>0</b>	<b>0</b>	<b>Potentiometer faulty, feedback changing too quickly: channel 5</b>
H/Ü			See S141
<b>151</b>	<b>&gt;88</b>	<b>3</b>	<b>Reci damper deactivated, out of time in reaching CLOSED position, channel:1</b>
H/Ü			The actuating device may not reach its set value since it is limited by a limit switch: Check the setting of the set values/limit switches.  The actuating device may not have reached its set value quickly enough. This is especially possible in the case of actuating devices that are activated separately and that must then travel the full distance (e.g., recirculation or exhaust valve or in case of a floating curve switchover): Increase the adjusting speed on the motor (if possible) or Limit the adjusting range by limit switch (to save runtime)  The return does not move even though the actuating device is moving: Check the connection of the return to the device (see the connection diagram) To localise the fault, simulate the return at various points of the return circuit (using a potentiometer or a current sensor).  The motor does not move: Check whether "OPEN" or "CLOSED" signals are present on the motor. Check the voltage supply circuit on the motor. FMS/VMS: Check whether the "OPEN" or "CLOSED" relay is actuated. If yes: Check the fuse of the relay module. If no: Make sure that no fault is present (can be seen on the fault LED). Check the F2 fuse (on the front panel of the power supply unit). Check the connection between FMS/VMS and the relay module.
<b>152</b>	<b>&gt;88</b>	<b>3</b>	<b>the same as P 151, but channel: 2</b>
H/Ü			See S151
<b>153</b>	<b>&gt;88</b>	<b>3</b>	<b>the same as P 151, but channel: 3</b>
H/Ü			See S151
<b>154</b>	<b>&gt;88</b>	<b>3</b>	<b>the same as P 151, but channel: 4</b>
H/Ü			See S151

## 8 System Operation

Fault Code No.	Restart according to		Description
	TRD	EN676	
155	>88	3	<b>the same as P 151, but channel: 5</b>
H/Ü			See S151
161	>88	3	<b>Monitoring direction of rotation: channel 1</b>
H/Ü			The channel is not running or does not start on time. During operation, the channel briefly changes direction. Check the servo motor.
162	>88	3	<b>Monitoring direction of rotation: channel 2</b>
H/Ü			The channel is not running or does not start on time. During operation, the channel briefly changes direction. Check the servo motor.
163	>88	3	<b>Monitoring direction of rotation: channel 3</b>
H/Ü			The channel is not running or does not start on time. During operation, the channel briefly changes direction. Check the servo motor.
164	>88	3	<b>Monitoring direction of rotation: channel 4</b>
H/Ü			The channel is not running or does not start on time. During operation, the channel briefly changes direction. Check the servo motor.
165	>88	3	<b>Monitoring direction of rotation: channel 5</b>
H/Ü			The channel is not running or does not start on time. During operation, the channel briefly changes direction. Check the servo motor.
171	>88	3	<b>Dead band over range too long: channel 1</b>
H			
172	>88	3	<b>Dead band over range too long: channel 2</b>
H			
173	>88	3	<b>Dead band over range too long: channel 3</b>
H			
174	>88	3	<b>Dead band over range too long: channel 4</b>
H			
175	>88	3	<b>Dead band over range too long: channel 5</b>
H			
181	>88	3	<b>Dead band under range too long: channel 1</b>
H			
182	>88	3	<b>Dead band under range too long: channel 2</b>
H			
183	>88	3	<b>Dead band under range too long: channel 3</b>
H			
184	>88	3	<b>Dead band under range too long: channel 4</b>
H			
185	>88	3	<b>Dead band under range too long: channel 5</b>
H			
191	1	1	<b>1st monitoring band over range too long: channel 1</b>
H/Ü			

## 8 System Operation

Fault Code No.	Restart according to		Description
	TRD	EN676	
192	1	1	1st monitoring band over range too long. Channel: 2
H/Ü			
193	1	1	1st monitoring band over range too long. Channel: 3
H/Ü			
194	1	1	1st monitoring band over range too long. Channel: 4
H/Ü			
195	1	1	1st monitoring band over range too long. Channel: 5
H/Ü			
201	1	1	1st monitoring band under range too long. Channel: 1
H/Ü			Parameter adjustment for drift compensation P.104 to 16 for prevention of sporadic faults H201 at ETAMATIC / FMS / VMS with constant control output.
202	1	1	1st monitoring band under range too long. Channel: 2
H/Ü			
203	1	1	1st monitoring band under range too long. Channel: 3
H/Ü			
204	1	1	1st monitoring band under range too long. Channel: 4
H/Ü			
205	1	1	1st monitoring band under range too long. Channel: 5
H/Ü			
211	0	0	2nd monitoring band over range too long. Channel: 1
H/Ü			
212	0	0	2nd monitoring band over range too long. Channel: 2
H/Ü			
213	0	0	2nd monitoring band over range too long. Channel: 3
H/Ü			
214	0	0	2nd monitoring band over range too long. Channel: 4
H/Ü			
215	0	0	2nd monitoring band over range too long. Channel: 5
H/Ü			
221	0	0	2nd monitoring band under range too long. Channel: 1
H/Ü			
222	0	0	2nd monitoring band under range too long. Channel: 2
H/Ü			
223	0	0	2nd monitoring band under range too long. Channel: 3
H/Ü			
224	0	0	2nd monitoring band under range too long. Channel: 4
H/Ü			
225	0	0	2nd monitoring band under range too long. Channel: 5
H/Ü			
231	>88	3	Fuel/air ratio control blocked: channel 1
H			

## 8 System Operation

Fault Code No.	Restart according to		Description
	TRD	EN676	
232	>88	3	<b>Fuel/air ratio control blocked: channel 2</b>
H			
233	>88	3	<b>Fuel/air ratio control blocked: channel 3</b>
H			
234	>88	3	<b>Fuel/air ratio control blocked: channel 4</b>
H			
235	>88	3	<b>Fuel/air ratio control blocked: channel 5</b>
H			
301	1	1	<b>Broken wire at firing rate input -1</b>
H/Ü			Check the wiring.
302	1	1	<b>Broken wire at firing rate input-2</b>
H/Ü			Check the wiring.
320	1	1	<b>Broken wire at correction input</b>
H/Ü			Check the wiring.
321	1	1	<b>Broken wire at feedback channel 1</b>
H/Ü			Check the wiring; check the potentiometers for short circuit.
322	1	1	<b>Broken wire at feedback channel 2</b>
H/Ü			Check the wiring; check the potentiometers for short circuit.
323	1	1	<b>Broken wire at feedback channel 3</b>
H/Ü			Check the wiring; check the potentiometers for short circuit.
324	1	1	<b>Broken wire at feedback channel 4</b>
H/Ü			Check the wiring; check the potentiometers for short circuit.
325	1	1	<b>Broken wire at feedback channel 5</b>
H/Ü			Check the wiring; check the potentiometers for short circuit.
351	1	1	<b>Different status of ignition position relay</b>
H/Ü			Check the signal for curve selection. Bouncing signal? Possible bus problems.
352	>88	3	<b>Invalid curve selection (no signals)</b>
H/Ü			Check the signal for curve selection. Possible bus problems.
353	>88	3	<b>Invalid curve selection (several signals)</b>
H/Ü			Check the signal for curve selection. Possible bus problems.
360	0	0	<b>Shut down from O<sub>2</sub>controller (1) or CO controller (2) :</b>
H			Initially, the time from parameter P904 "O <sub>2</sub> trim active after ignition in seconds" runs out before the fault is permitted.
361	1	1	<b>Different status of ignition position relay</b>
H/Ü			
362	0	0	<b>carry out burner servicing</b>
H/Ü			The maintenance counter is reset by changing parameter 713 or 714

## 8 System Operation

Fault Code No.	Restart according to		Description
	TRD	EN676	
363	1	1	<b>permissible O<sub>2</sub> value was fallen below</b> Initially, the time from parameter P904 "O <sub>2</sub> trim active after ignition in seconds" runs out before the fault is permitted. After that, the monitoring time from P966 starts. Also works without an active O <sub>2</sub> controller (from 5.4): After ignition, the monitoring time from P966 starts immediately.
370	0	0	<b>Internal communication between the processors faulty</b> Different values in the main and monitoring processors. Reimport the curves and/or parameter set. A sporadic occurrence of fault H370 is due to EMC interference immunity of the wiring or environment. If the fault persists, exchange the processor pc board.
H/Ü			
371	0	0	<b>Output for internal firing rate faulty</b>
Ü			
372	0	0	<b>Deviation of the firing rate value between the main processor and the monitoring processor is too high.</b> Fault during an internal self-test. Reset the fault; switch the mains voltage off and on again if necessary. Check all fuses in the device. If fault messages are constantly appearing one after the other <Symbol Format="Symbol">→ </Symbol> exchange the device or respective card.
Ü			
381	0	0	<b>Deviation between main processor and monitoring processor too great: correction channel 1</b> Fault during an internal self-test. Reset the fault; switch the mains voltage off and on again if necessary. Check all fuses in the device. If fault messages are constantly appearing one after the other → exchange the device or the respective card.
Ü			
382	0	0	<b>Deviation between main processor and monitoring processor too great: correction channel 2</b> Fault during an internal self-test. Reset the fault; switch the mains voltage off and on again if necessary. Check all fuses in the device. If fault messages are constantly appearing one after the other <Symbol Format="Symbol">→</Symbol> exchange the device or the respective card.
Ü			
391	0	0	<b>Curves sentence does not fit to the chosen fuel.</b> Fault during an internal self-test. Reset the fault; switch the mains voltage off and on again if pertinent. Check all fuses in the device. At the curve set selection by BUS, terminal 75 is missing for plausibility check, or rather terminal 75 can be seen at oil curve. If fault messages are constantly appearing one after the other <Symbol Format="Symbol">→ </Symbol> exchange the device or the respective card.
Ü			
392	0	0	<b>Remote not responding (time-out)</b>
H			
393	0	0	<b>Remote shut down triggered.</b>
H			
394	0	0	<b>BURNER-ON/OFF Remote signal missing.</b>
400	0	0	<b>Different point number at programming</b>
Ü			Re-enter the curve.

## 8 System Operation

Fault Code No.	Restart according to		Description
	TRD	EN676	
<b>451</b>	<b>1</b>	<b>1</b>	<b>Ignition position was left in ignition mode. Channel: 1</b>
H/Ü			In case of a constant output: Possible EMC influences due to ignition transformer; check the frequency converter settings
<b>452</b>	<b>1</b>	<b>1</b>	<b>Ignition position was left in ignition mode. Channel: 2</b>
H/Ü			In case of a constant output: Possible EMC influences due to ignition transformer; check the frequency converter settings
<b>453</b>	<b>1</b>	<b>1</b>	<b>Ignition position was left in ignition mode. Channel: 3</b>
H/Ü			In case of a constant output: Possible EMC influences due to ignition transformer; check the frequency converter settings
<b>454</b>	<b>1</b>	<b>1</b>	<b>Ignition position was left in ignition mode. Channel: 4</b>
H/Ü			In case of a constant output: Possible EMC influences due to ignition transformer; check the frequency converter settings
<b>455</b>	<b>1</b>	<b>1</b>	<b>Ignition position was left in ignition mode. Channel: 5</b>
H/Ü			In case of a constant output: Possible EMC influences due to ignition transformer; check the frequency converter settings
<b>500</b>	<b>0</b>	<b>0</b>	<b>Internal comparison: relay out terminal 67 not picking up.</b>
H			Fault during an internal self-test. Reset the fault; switch the mains voltage off and on again if necessary. Check all fuses in the device. If fault messages are constantly appearing one after the other <Symbol Format="Symbol">→ </Symbol> exchange the device or respective card.
<b>501</b>	<b>0</b>	<b>0</b>	<b>Internal comparison: The relay output terminal 43 or 68 (ETAMATIC) does not respond.</b>
H			See S500
<b>502</b>	<b>0</b>	<b>0</b>	<b>Internal comparison: relay out terminal 16 or 65 (ETAMATIC) not picking up.</b>
H			See S500
<b>503</b>	<b>0</b>	<b>0</b>	<b>Internal comparison: relay out terminal 11 or 66 (ETAMATIC) not picking up.</b>
H			See S500
<b>504</b>	<b>0</b>	<b>0</b>	<b>Internal comparison: relay out terminal 45 not picking up.</b>
H			See S500
<b>505</b>	<b>0</b>	<b>0</b>	<b>Internal comparison: relay out terminal 68 or 61 (ETAMATIC) not picking up.</b>
H			See S500
<b>506</b>	<b>0</b>	<b>0</b>	<b>Internal comparison: relay out terminal 36 (ETAMATIC K202) not picking up.</b>
H			See S500
<b>507</b>	<b>0</b>	<b>0</b>	<b>Internal comparison: relay out terminal 41 not picking up.</b>
H			See S500
<b>508</b>	<b>0</b>	<b>0</b>	<b>Internal comparison: relay out terminal 76 not picking up.</b>
H			See S500
<b>509</b>	<b>0</b>	<b>0</b>	<b>Internal comparison: Output K203 not picking up.</b>
			See S500
<b>510</b>	<b>0</b>	<b>0</b>	<b>Internal comparison: Output K201 not picking up.</b>
			See S500

## 8 System Operation

Fault Code No.	Restart according to		Description
	TRD	EN676	
520	0	0	Internal comparison: relay output terminal 67 not dropping out.
H			See S500
521	0	0	<b>Internal comparison: relay output terminal 43 or 68 (ETAMATIC) not dropping out.</b>
H			See S500
522	0	0	<b>Internal comparison: relay output terminal 16 or 65 (ETAMATIC) not dropping out.</b>
H			See S500
523	0	0	<b>Internal comparison: relay output terminal 11 or 66 (ETAMATIC) not dropping out.</b>
H			See S500
524	0	0	<b>Internal comparison: relay output terminal 45 not dropping out.</b>
H			See S500
525	0	0	<b>Internal comparison: relay output terminal 68 or 61 (ETAMATIC) not dropping out.</b>
H			See S500
526	0	0	<b>Internal comparison: relay output terminal 36 not dropping out.</b>
H			See S500
527	0	0	<b>Internal comparison: relay output terminal 41 not dropping out.</b>
H			See S500
528	0	0	<b>Internal comparison: relay output terminal 76 not dropping out.</b>
H			See S500
529	0	0	<b>Internal comparison: Output K203 not dropping out.</b>
			See S500
530	0	0	<b>Internal comparison: Output K201 not dropping out.</b>
			See S500
540	0	0	<b>TRIAC selftest : optical couplers are not OFF</b>
			See S500
541	0	0	<b>TRIAC selftest : all TRIACS are not supplied with voltage!</b>
			Terminal 60 not connected or fuse F5 defective. Check whether terminals 26 and 60 are supply by the same phase. See S500
542	0	0	<b>TRIAC selftest : main gas 1 is currentless</b>
			See S500
543	0	0	<b>TRIAC selftest: main gas 2 is currentless</b>
			If a test current is flowing during the TRIAC self test and no test current is at the terminal for Main Gas 2, the software assumes that a fault is present. - The connector of Main Gas 2 is not connected - The solenoid valve is defective - The TRIAC for Main Gas 2 is defective in ETAMATIC. If the device only works for oil operation - disconnect Main Gas 1.
544	0	0	<b>TRIAC selftest : oil pump is currentless</b>
			See S500

## 8 System Operation

Fault Code No.	Restart according to		Description
	TRD	EN676	
545	0	0	<b>TRIAC selftest : oil valve is currentless</b> See S500
546	0	0	<b>TRIAC selftest : Ignition transformer is currentless</b> See S500
547	0	0	<b>TRIAC selftest : ignition valve is currentless</b> See S500
550	0	0	<b>Oil fuel blocked because a required solenoid valve is not connected</b> The test current for the TRIAC self-test cannot flow.
551	0	0	<b>Gas fuel blocked because a required solenoid valve is not connected</b> The test current for the TRIAC self-test cannot flow.
552	0	0	<b>No valve connected? Check fuse F3 and F4</b> The oil and gas valves are not connected.
600	0	0	<b>Programme check time of sequencer expired.</b> H/Ü If no ignition takes place after starting within this time (parameter 777) after 'Burner ON,' a fault is output. If the parameter is set to 0, no fault appears.
601	0	0	<b>Leak check fault: gas pressure still applied.</b> H/Ü
602	0	0	<b>Leak check fault: gas pressure missing.</b> H/Ü
603	0	0	<b>Vent gas line manually.</b> H/Ü
604	0	0	<b>Flame signal not arriving in time.</b> H/Ü
605	>88	3	<b>Oil pressure &lt; min !!!</b> H
606	1	1	<b>Gas &gt; min appears in oil operation.</b> H
607	1	1	<b>Ignition position acknowledgement dropping.</b> H
608	0	0	<b>Boiler safety chain dropping.</b> H
609	1	1	<b>Gas safety chain dropping.</b> H
610	>88	3	<b>Oil safety chain dropping.</b> H
611	>88	3	<b>Gas pressure too low</b> H/Ü
613	0	0	<b>Air pressure signal missing.</b> H
614	1	1	<b>F.A. safety interl. chain gets OFF</b>
615	0	0	<b>Flame is blown away during blow out of oil lance</b>

## 8 System Operation

Fault Code No.	Restart according to		Description
	TRD	EN676	
616	1	1	Ignition flame goes out in standby operation
617	1	1	Continuous ignition flame goes out under operation
618	0	0	Oil circulation: Temperature does not rise up within 45 sec.
620	0	0	Oil lance blow out: Delay for opening not kept
621	0	0	Oil lance blow out: Oil valve actuator not in ignition position
622	0	0	Oil lance blow out: blow out period too long
623	0	0	Atomizer switch-ON-pre-period not kept
624	>88	3	Oil pressure too low
625	>88	3	Oil pressure too high
626	>88	3	Atomizer air pressure too low
627	>88	3	General safety chain missing
700	0	0	Pre-ventilating signal present, without signal on terminal 2.
H			VMS, for ETA V Term. 58
701	0	0	Flame signal present, without signal on terminal 2.
H			VMS, for ETA V Term. 58
702	0	0	Flame signal appears during pre-ventilating.
H			VMS, for ETA V Term. 58
703	0	0	Flame signal goes out even though signal on terminal 2 still present.
H			VMS, for ETA V Term. 58
711	0	0	Illegal operating mode change
Ü			Check the "Burner ON" signal. Bouncing signal?
712	0	0	
713	0	0	Incorrect signal combination in operating mode AU
Ü			
714	0	0	Incorrect signal combination in operating mode BE
Ü			
715	0	0	Incorrect signal combination in operating mode VO
Ü			
716	0	0	Incorrect signal combination in operating mode ZP
Ü			
717	0	0	Incorrect signal combination in operating mode ZU
718	0	0	
719	0	0	Fuel valves open too long without flame
Ü			
720	0	0	Ignition transformer switched on too long
Ü			
721	0	0	Ignition valve open too long
Ü			
722	0	0	Fuel valves open in maintenance mode
Ü			
723	0	0	Ignition process taking too long
Ü			

## 8 System Operation

Fault Code No.	Restart according to		Description
	TRD	EN676	
724 Ü	0	0	Gas valves open when burning oil
725 Ü	0	0	Oil valves open when burning gas
726 Ü	0	0	Main gas 2 open without main gas 1
727 Ü	0	0	Main gas 1 illegally open
728 Ü	0	0	Main gas valves and ignition valve open too long
729 Ü	0	0	Ignition process taking too long (without pilot burner)
730 Ü	0	0	Maintenance mode without pilot burner
731 Ü	0	0	Ignition valve opened without ignition burner
732 Ü	0	0	Incorrect signal combination during operation
733 Ü	0	0	Incorrect signal combination after operation
734 Ü	0	0	Pre-ventilating time not complied with
735 Ü	0	0	Fuel safety chain missing
736 Ü	0	0	Leak check: both gas valves open
737 Ü	0	0	Seal tightness check: Main Gas 2 delayed for too long at deactivation.
738 Ü	0	0	Leak check: main gas 2 missing
739 Ü	0	0	Seal tightness check: Main Gas 2 open for too long.
740 Ü	0	0	Seal tightness check: Main Gas 1 leaky.
741 Ü	0	0	Seal tightness check: Main Gas 1 open for too long.
742 Ü	0	0	Seal tightness check: Main Gas 2 leaky.
743 Ü	0	0	Flame monitoring: flame after-burn too long Burning duration (parameter 789) set to be too short.
744 Ü	0	0	Flame monitoring: flame on again

## 8 System Operation

Fault Code No.	Restart according to		Description
	TRD	EN676	
745	0	0	Programme check time exceeded.
Ü			
746	0	0	Solenoid value switch-off faulty
Ü			
747	0	0	Leak check: ventilating into boiler not allowed
Ü			
750	0	0	Shut-down on faults via bus.
Ü			
751	>88	3	No data transfer via the bus (time-out).
Ü			
759	0	0	The "Setting" operating mode exceeded the 24-hour time limit.
760	0	0	Change of curve selection during setting not allowed
H/Ü			
761	0	0	Change of curve lasts too long
			The curve set change takes too long/could not be performed. e.g.: The fuel safety chain is missing
763	0	0	different curve selection between the processors
764	1	1	CO-Controller, internal fault no. -
765	0	0	Parameter setting error: The channel for solo-fuel is not to determine.
			Check the parametrisation of the channel configuration.
766	0	0	The limited firing rate (maximum firing rate without additional-fuel) does not exist in the priority curves
			Check the programming of the priority curves (assignment of the fuel channels and their programming).
767	0	0	One parameter of the interpolation type for non-fuels is invalid
			Check parameters 390 through 394
768	0	0	The curve set variable for the assigned air channel (1 = priority, 2 = additional curve) is invalid.
			Compare solo curves and priority curves as they possibly have different firing rate points!
769	0	0	Ignition while mixed fuel operation or burner-start with solo fuel-A
			Ignition is permitted only in a solo curve set. FMS: Ignition is permitted only with the oil or gas solo curve set, but not with solo fuel A.
770	0	0	Fill-Time for fuel-A too long
791	>88	3	Bus master is in a stop.
Ü			
792	>88	3	Bus data length incorrectly configured.
Ü			
793	>88	3	Bus master is decoupled.
Ü			
800	0	0	Error in parameters, for parameter no.:
H/Ü			
888	0	0	Fault block activated !

## 8 System Operation

Fault Code No.	Restart according to		Description
	TRD	EN676	
889	0	0	<b>Remote-fault-reset happens within a too short distance</b>
			<p>EN 14459 permits a remote unlocking only 4 x within 15 minutes. The fault release is monitored by the remote control software, LAMTEC system bus, and field bus (parameter 19). When exceeded, fault deactivation H889 is generated and additional remote fault releases are ignored. After a waiting period, another remote fault release can be performed. Fault deactivation H889 also takes place if the fault release was sent even though none is present!</p> <p>The release is monitored by terminal, while the programming unit and customer interface are switched of by the standard setting of parameter 19. A release through the front panel is always possible.</p>
900	0	0	<b>Error in self-test sequencer.</b>
H/Ü			<p>Fault during an internal self-test. Reset the fault; switch the mains voltage off and on again if necessary. If fault messages are constantly appearing one after the other → exchange the device or respective card. If the fault appears after a software update, the version of the monitoring processor may be incompatible with the version of the main processor.</p>
901	0	0	<b>Terminal 10 + 24 Volt switch-off faulty.</b>
H/Ü			<p>Fault during an internal self-test. Reset the fault; switch the mains voltage off and on again if necessary. Check all fuses in the device. If fault messages are constantly appearing one after the other → exchange the device or respective card.</p>
902	0	0	<b>Error in over-voltage self-test.</b>
H/Ü			<p>Fault during an internal self-test. Reset the fault; switch the mains voltage off and on again if necessary. Check all fuses in the device. If fault messages are constantly appearing one after the other → exchange the device or respective card.</p>
903	0	0	<b>Error in optical coupler self-test terminal -</b>
H/Ü			<p>Fault during an internal self-test. Reset the fault; switch the mains voltage off and on again if necessary. Check all fuses in the device. If fault messages are constantly appearing one after the other → exchange the device or respective card.</p> <p>For ETAMATIC:            Are another 24V than those of terminal 24 being used?            Check the voltage level.            Short circuit on the 24V            Disconnect 24: no arrow must be pointing at digital inputs.            Connect terminal 24 to only one input            Voltage on            If the fault still occurs: Deactivation in ETAMATIC defective.</p>

## 8 System Operation

Fault Code No.	Restart according to		Description
	TRD	EN676	
<b>904</b>	<b>1</b>	<b>1</b>	<b>Error in reference of firing rate</b>
Ü			<p>Fault during an internal self-test. Reset the fault; switch the mains voltage off and on again if necessary. Check all fuses in the device. If fault messages are constantly appearing one after the other → exchange the device or respective card.</p> <p>Using the device enter the Setting mode for about 3 seconds and then return to the Automatic mode to reimport the reference voltage. The potentiometer possibly has the incorrect polarity, is incorrectly connected (centre pick-up mixed up with the outer one), or is defective.</p>
<b>905</b>	<b>1</b>	<b>1</b>	<b>Error in reference element of main processor</b>
Ü			<p>Fault during an internal self-test. Reset the fault; switch the mains voltage off and on again if necessary. Check all fuses in the device. If fault messages are constantly appearing one after the other → exchange the device or respective card.</p>
<b>906</b>	<b>1</b>	<b>1</b>	<b>Error in reference element of monitoring processor</b>
H			<p>Fault during an internal self-test. Reset the fault; switch the mains voltage off and on again if necessary. Check all fuses in the device. If fault messages are constantly appearing one after the other → exchange the device or respective card.</p>
<b>907</b>	<b>1</b>	<b>1</b>	<b>Curve set adjustment via LAMTEC SYSTEM BUS, selftest recognizes fault</b>
<b>911</b>	<b>1</b>	<b>1</b>	<b>Error in reference, channel: 1</b>
Ü			<p>Fault during an internal self-test. Reset the fault; switch the mains voltage off and on again if necessary. Check all fuses in the device. If fault messages are constantly appearing one after the other → exchange the device or respective card.</p> <p>Using the device enter the Setting mode for about 3 seconds and then return to the Automatic mode to reimport the reference voltage. The potentiometer possibly has the incorrect polarity, is incorrectly connected (centre pick-up mixed up with the outer one), or is defective.</p>
<b>912</b>	<b>1</b>	<b>1</b>	<b>Error in reference, channel: 2</b>
Ü			See S911
<b>913</b>	<b>1</b>	<b>1</b>	<b>Error in reference, channel: 3</b>
Ü			See S911
<b>914</b>	<b>1</b>	<b>1</b>	<b>Error in reference, channel: 4</b>
Ü			See S911
<b>915</b>	<b>1</b>	<b>1</b>	<b>Fault in reference, duct: 5</b>
Ü			See S911

## 8 System Operation

Fault Code No.	Restart according to		Description
	TRD	EN676	
<b>921</b>	<b>0</b>	<b>0</b>	<b>Relay driver self-test : output terminal 11 or 66 (ETAMATIC) faulty.</b>
H/Ü			<p>Fault during an internal self-test. Reset the fault; switch the mains voltage off and on again if necessary. Check all fuses in the device. If fault messages are constantly appearing one after the other → exchange the device or respective card.</p> <p>FMS with 660 R 0016 V4.3 when the burner is at a standstill: Check the wiring between FMS and 660 R 0016 V4.3. If the wiring has been performed correctly: exchange 660 R 0016 V4.3.</p> <p>FMS with 660 R 0016 V4.3 at start of burner: From the start of the burner, relay module type 660 R 0016 V4.3 checks the following outputs:</p> <ul style="list-style-type: none"> <li>- Ignition transformer (terminal 86)</li> <li>- Ignition valves (terminal 85)</li> <li>- Oil valves (terminal 84)</li> <li>- Main Gas 1 (terminal 82)</li> <li>- Main Gas 2 (terminal 83)</li> </ul> <p>If faults H921 (in case of starting with gas as the fuel), H923, H924 (in case of starting with O<sub>2</sub> as the fuel) occur by the time ignition is completed, the following faults may be present:</p> <ul style="list-style-type: none"> <li>- Lack of or too little firing rates at terminals 82 through 86</li> <li>- Failure of fuses F1-F4 or F6</li> <li>- Actual defect in one of the safety-related switching channels</li> </ul> <p>For further troubleshooting, the diagnostic mode can be activated (see DLT6089/ DLT6065).</p>
<b>922</b>	<b>0</b>	<b>0</b>	<b>Relay driver self-test : output terminal 16 or 65 (ETAMATIC) faulty.</b>
H/Ü			See S921
<b>923</b>	<b>0</b>	<b>0</b>	<b>Relay driver self-test : output terminal 43 or 68 (ETAMATIC) faulty.</b>
H/Ü			See S921
<b>924</b>	<b>0</b>	<b>0</b>	<b>Relay driver self-test : output terminal 67 faulty</b>
H/Ü			See S921
<b>925</b>	<b>0</b>	<b>0</b>	<b>Relay driver self-test : output terminal 45 faulty.</b>
H/Ü			See S921
<b>926</b>	<b>0</b>	<b>0</b>	<b>Relay driver self-test : output terminal 68 or 61 (ETAMATIC) faulty.</b>
H/Ü			See S921
<b>927</b>	<b>0</b>	<b>0</b>	<b>Relay driver self-test : output terminal 36 (ETAMATIC K202) faulty.</b>
H/Ü			See S921
<b>928</b>	<b>0</b>	<b>0</b>	<b>Relay driver self-test : output terminal 41 faulty.</b>
H/Ü			See S921
<b>929</b>	<b>0</b>	<b>0</b>	<b>Relay driver self-test : output terminal 76 faulty</b>
H/Ü			See S921
<b>930</b>	<b>0</b>	<b>0</b>	<b>Relay driver self-test : Output K203 defect.</b>
H/Ü			See S921
<b>931</b>	<b>0</b>	<b>0</b>	<b>Relay driver self-test : Output K201 defect.</b>
H/Ü			See S921

## 8 System Operation

Fault Code No.	Restart according to		Description
	TRD	EN676	
997	>88	3	<b>Default language missing or LANGUAGE-FLASH defect</b> Fault during an internal self-test. Reset the fault; switch the mains voltage off and on again if necessary. Check all fuses in the device. If fault messages are constantly appearing one after the other → exchange the device or respective card.
998	0	0	<b>Internal fault: main loop is too slow.</b>
H/Ü			Fault during an internal self-test. Reset the fault; switch the mains voltage off and on again if necessary. Check all fuses in the device. If fault messages are constantly appearing one after the other <Symbol For- mat="Symbol">→</Symbol> exchange the device or respective card.
999	0	0	<b>Internal fault Number -</b>
H			The internal procedure is faulty, and the additional number indicates the position of the fault within the firmware. Internal fault number 2: This fault is triggered by the watchdog processor, when these do not match with the burner sequencer's behaviour of the main processor. Possible cause: The HP activates the maintenance mode without any permission The HP changes into a mixed operation without any permission Internal fault number 3: If the fault occurs once, it may be caused by EMC interference. If the fault occurs often, the processor pc board is defective. Internal fault number 4: The monitoring processor has not detected a signal change at the "Air pressure monitor" input. This can occur if the "Air pressure monitor" input is present at BURNER START and is only briefly deactivated. This fault occurs frequently when the fan is started by an external control system. ETAMATIC: Before A4a4002: the "Air pressure monitor" input appears during the TRIAC self-test before the fan output is actuated by ETAMATIC! Internal fault number 7: This fault occurs when the "Burner On" and "Pre-venting" signals occur in the wrong order or too quickly in sequence during the postpurge time in the case of devices without a burner sequencer (VMS / ETAMATIC V). No fault occurs if the devices switches to the "Ready" (BE) mode downstream of the "Burner On" input before the "Pre-venting" signal is sent. Internal fault number 22: A fault occurred during the assumption of the curve in the EEPROM. → Check the curve. Re-enter if required. This fault is possible only in connection with the programming unit! Fault during an internal self-test. Reset the fault; switch the mains voltage off and on again if necessary. Check all fuses in the device. If fault messages are constantly appearing one after the other → exchange the device or respective card.

## 9 Maintenance

### 9.1 Changing EPROMs

#### 9.1.1 Replacing a Data EEPROM

---

##### ***Change EEPROM***

1. Unplug power supply.
2. Loose front panel and detach it.
3. Remove the processor board (the most left handed board) and put it beside, if necessary remove the additional board (on the processor board).
4. Remove the chips carefully and replace them with new ones.
5. Ensure that
  - a) the chip shows in the right direction (slots of the upper chip line and the lower chip line are reverse).
  - b) all pins are inserted well.
  - c) the right chip is replaced.
6. Press it again and plug in the additional board
7. Move the card into the VMS again.
8. Plug in the front panel.
9. Move the cards completely into the housing.
10. Screw tightly.
11. Unplug in the power supply.



##### **WARNING!**

It may damage the device if you mix the data EEPROM and the program EPROM up.

---

##### **NOTICE**

If you replace the device, but you want to use the programmed curves in the new device, note, that you must plug the data EEPROM of the main processor and the EEPROM of the watch-dog processor from the old device into the new device.

But if you have saved the data in your computer, you may reload them into the new device.

---

### 9.1.2 Re-enter Range Limits

#### NOTICE

When adjusting the limit switches after programming, the range limits must be redefined.

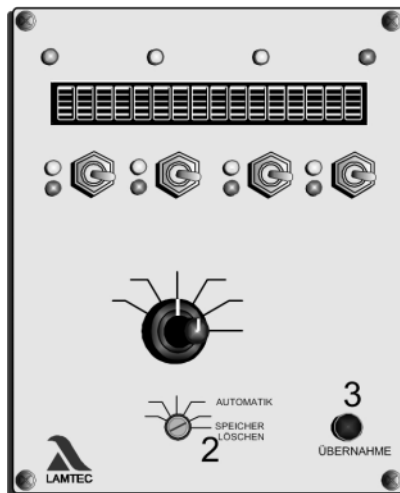

Switch (2) to CLEAR MEMORY

Press ENTER (3)

→ the curve and the range limits are cleared

Switch (2) back to AUTOMATIC

→ the display shows 'restore previous curve?'

press channel key 3 (5) upwards to quit the message

→ the display shows 'read old curve'

→ since no point is been entered, the old curve is reactivated, but the range limits remain clear

Pre-purge plant

→ Range limits will be re-entered.

#### NOTICE

This may be observed at setpoint switch setting. Without limits, the setpoint value is 0 or 999. If the limits are defined, the setpoint skips to the actual value.

## 9.2 Installing a New Software Version

### 9.2.1 Procedures for New Software Installation

insert EPROMS

- M-EPROM on board at the top, left
- main processor-EPROM on board down left

Power ON

- Display: LAMTEC VMS 4/5
- Self tests

#### NOTICE

Please remember that the installation of modified software in a system that has already undergone acceptance will require a new acceptance or at least approval of the modification by the competent authorities. The new EPROM numbers (displayed during the start-up self-tests) are to be inserted accordingly.

## 10 Appendix

### 10.1 Wiring According to EMC

#### 10.1.1 Shields Connection

---

All cables from and to the VMS must be shielded (with the exception of the 230 V cable). Connect the shielding to PE by the shortest possible route.

**Right:**



**Wrong:**

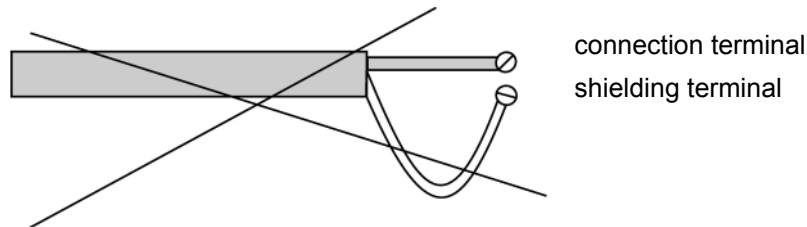

#### 10.1.2 PE Busbar

---

On the back of the unit two bars are fitted left and right parallel to the terminal strips. All screening is to be laid up to those bars. Although this bar already has a connection to PE via the housing, the fault leakage conduction is improved if a separate, low-impedance PE wire is laid to each of these in addition.

#### 10.1.3 Control Cabinet Wiring

---

The low-voltage cables from and to the VMS should not run in parallel to the power electronics' in and out conductors in one cable duct.

Frequency converter cables and switches/contacts carrying high inductive or capacitive firing rates are particularly critical. Therefore, avoid routing parallel to the drive cables of solenoid valves, ignition transformers, servo motors and similar devices.

Although this device exceeds all relevant EMC standards in some respects, suitable wiring is essential to ensure that the entire system operates smoothly in all conditions.

##### **Shielding of supply lines out of the field:**

The best method of connecting supply lines out of the field (e.g. potentiometer line) is to connect them directly (without additional terminals).

If you need additional terminals, you must connect the shielding beside this terminals

Avoid long distances in the cable duct.

## 10 Appendix

### 10.1.4 Shielding Cables from the Field

---

Screening of leads from the field

Screened leads from the field (e.g. potentiometer leads) are best laid directly to the VMS (without intermediate terminals).

Should intermediate terminals be necessary, the screening is also to be led immediately alongside by the terminal. Long distances in the conduit without screening should be avoided.

### 10.2 Feedback at Three-Point-Step Channels

#### 10.2.1 Connect with Positive Locking

---

Since the VMS, in the case of three-point step channels, adjusts the damper until the actual value is equal to the setpoint value, the feedback potentiometer must always reliably correspond to the damper position.

The damper motor potentiometer connections must be positive interlock connections, i.e. not able to rotate.

In addition you must use potentiometers with high quality standards (see next page). If one of these two points is not given, you must use two independent potentiometers (not dual-operated potentiometers) per channel for the feedback.

The motor damper connection must always be a positive interlock.



#### **WARNING!**

The connection has to be designed in that way that the maximum torque of the motor could not break the connection under any condition.

---

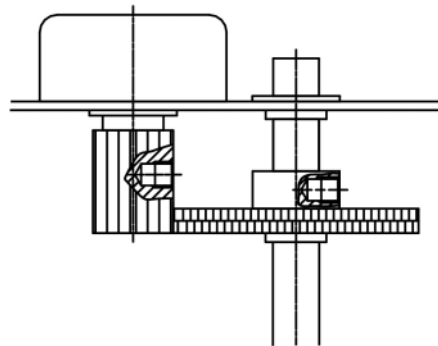

*Fig. 10-1 Example of positive potentiometer connection*

#### 10.2.2 Fail-Safe Feedback

---

In the case of single-channel feedback of TPS outputs, only authorised potentiometers may be used. These must be switched directly.

## Example of potentiometers:

The following potentiometers are authorised for use as solo feedback in the case of VMS, on condition that they are positively connected to the damper:

Manufacturer	Type	Rating
Novotechnik	SP-Serie	Rating: 5 kΩ*
Contelec	PL 240	Rating: 1 kΩ - 5 kΩ*
Contelec	PL 310	Rating: 5 kΩ*
Contelec	PL 295	Rating: 5 kΩ*
Bourns	6639S-095-..	Rating: 5 kΩ*

Other potentiometers are permitted only after consulting LAMTEC or the TÜV.

## Examples of servomotors

Servomotors with approved potentiometer, fitted with a positive interlock connection:

Manufacturer	Description	Potentiometer
LAMTEC	662R2111... 662R2112... 662R2121... 662R2127... 663R3100...	Novotechnik Novotechnik Novotechnik Novotechnik Megatron
Schimpf	All motors with feedback type R01*/type R02* 01-..., 02-...	Novotechnik
Haselhofer	HD 60 D 2 HD 60 D10 D1, D2, D3, D10, (Saake HD60...) , SBA12 D006, D025, D040, D100, D012	Novotechnik Contelec Contelec
Aris	WAN 1 - WAN 6 WAK..., WAV  NL6020, NL6040 N1, N2A NK1510, NK3010, NK6010	Contelec Contelec  Contelec, Megatron Megatron Megatron
Schneider Electric	STM 40 Q15.51 /8 2NL POT	Contelec
Siemens AG	SQN..., SQM...	Contelec
auma-Werner Riester Gmbh & Co. KG	SA07.1, SA07.5, SA10.1, SA14.1, SA14.5, SA16.1, SA25.1, SA30.1, SA35.1, SA40.1, SA48.1	Contelec
ARI-Armatur Albert Richter GmbH & Co. KG	ARI PREMIO 2,2 kN, 5,0 kN, 12,0 kN, 15,0kN	Megatron
Keller GmbH	CA 03 AF 325, CA 12 AF 148	Contelec
KFM Regelungstechnik GmbH	4d124B	Novotechnik
Regeltechnik Kornwestheim GmbH	ST 5102, ST5113	Contelec

\* also available at LAMTEC

Other motors are allowable only if the potentiometer connection forms a positive interlock.

### 10.3 External Switching of the Fuel Motors/ Valves

---

If there are not enough output channels, it is possible to switch externally between actuators, which are not needed in every curve set (oil motors and gas motors).

#### **WARNING!**

If you use an external switching you must recognise this for safety reasons:  
You must ensure that the feedback of the selected motor is also selected, e.g. by using relays with connected switches.

---

#### **WARNING!**

For switching the feedback signals, you may only use relays with gold contact material.

---

#### **NOTICE**

Recommendation:

Use relay module R30 (type 660R0030) for external switching of the fuel actuators. For informations about the relay module R30 refer to the data sheet of the relay module (print no. DLT6105).

---

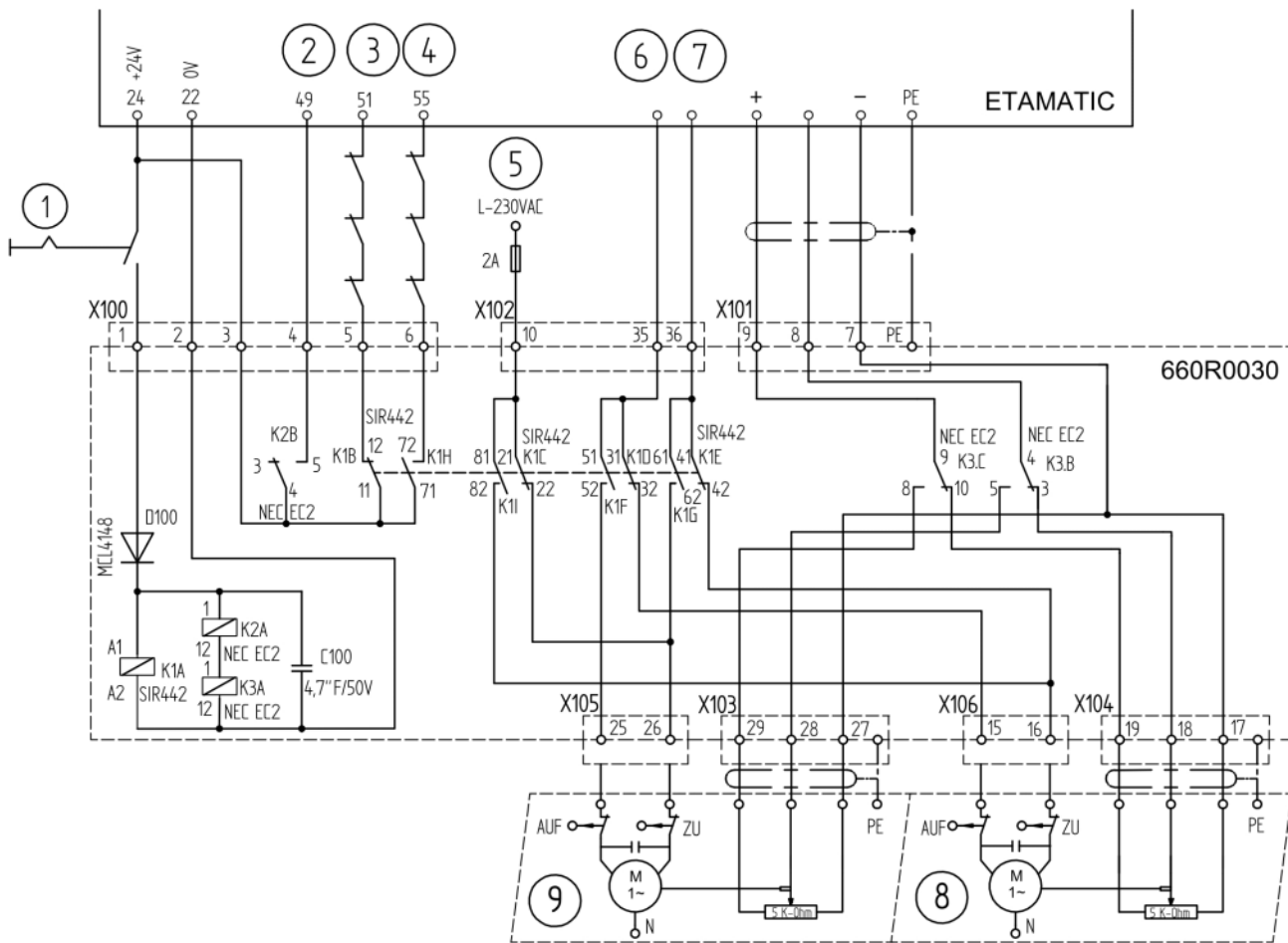

Fig. 10-2 Circuit diagram relay module 660R0030

**Legend:**

No.	Description
1	Fuel selection
2	Fuel selection
3	Safety interlock chain oil
4	Safety interlock chain gas
5	L 230VAC, delay fuse provided
6	Open
7	Close
8	Control drive oil
9	Control drive gas

## 10.4 Changing Control Drives / Potentiometers

### 10.4.1 How to replace a motor with LAMTEC pre-calibration

Replacing a pre-calibrated motor with another pre-calibrated motor is easy. Normally there are no burner adjustments necessary after the change.

### NOTICE

Motors with LAMTEC pre-calibration are adjusted at LAMTEC in that way that 0 - 90° degree has the same potentiometer value at every motor. Therefore a change of such motors is possible without adapting the curves in the VMS to the new motor.



### WARNING!

It is not allowed to change any adjustment in a pre-calibrated motor (e.g. potentiometer or switches). Otherwise the pre-calibrated characteristic will be lost. The burner has to be re-adjusted then.

#### 10.4.2 How to Replace a Complete Control Drive

If you replace a motor without pre-calibration it is necessary to check the burner adjustment after the change, because the potentiometer value and the position of the switches may differ a little bit. This may lead to an other position of the damper.



### WARNING!

Therefore you must prove the burner adjustment again in all firing rate positions and all operation modes. If necessary adapt the curves in the VMS.

#### 10.4.3 How to Replace a Potentiometer



### WARNING!

Keep switches in the same position.

- 1 Note actual feedback value at lowest position before changing the potentiometer.
- 2 Remove old potentiometer.
- 3 Insert new potentiometer and adjust it so that actual value feedback at lowest position is the same like noted before.
- 4 Fix potentiometer in according to the instruction of the motor manufacturer.
- 5 Verify burner adjustments and change if necessary



### WARNING!

Since the normally used potentiometers can have different values, it is possible that the damper has another position than before. Therefore you must prove the burner adjustment n again after a potentiometer change, at all firing rate points and in all operation modes.

### 10.5 Schalter und Tastenkombination der Bedieneinheit

#### 10.5.1 Front Panel VMS/FMS

## 10 Appendix

Action	Switch position top selector switch (1)	Switch position bottom selector switch (2)	Buttons/Other
Recall correction ranges	STATUS	MONITORING DISPLAY AUTOMATIC SETTING CLEAR MEMORY	ENTER
Cold start (long reset)	STATUS		FAULT/Switch 1 OPEN
Warm start (short reset)	STATUS		FAULT/Switch 1 OPEN and switch 2 OPEN
Code entry for parameterisation	STATUS	AUTOMATIC MONITORING DISPLAY	Switch 2/3 OPEN Switch 4 CLOSE
Scan fault history	STATUS	MONITORING DISPLAY AUTOMATIC SETTING CLEAR MEMORY	Switch 1 OPEN or CLOSE (not in FAULT mode)
Recall correction input values	LOAD RATING		ENTER
Firing-rate adjustable via switch 1 (MANUAL OPERATION)	LOAD RATING	AUTOMATIC	Switch 1 OPEN/CLOSE
Quit MANUAL OPERATION	LOAD RATING	AUTOMATIC	operate a switch, channel 2,3 or 4
Firing-rate adjustable via switch 1 (internal firing-rate default)	LOAD RATING	SETTING	Switch 1 OPEN or CLOSE
EG / ES mode is activated	LOAD RATING	SETTING CLEAR MEMORY	Switch 3 CLOSE Fuel/air ratio control engaged (No 'ES barred' message)
EG / ES mode is terminated		SETTING CLEAR MEMORY	Switch on the front panel operated EG or ES mode
Display is running time meter/Status counter	SETPOINT	MONITORING DISPLAY AUTOMATIC	ENTER
Store point	SETPOINT ACTUAL VALUE FEEDBACK	SETTING	ENTER
Clear present curve	SETPOINT	CLEAR MEMORY	ENTER
Display of acceptance data CRCs for all levels Oil/gas safety times pre-purge time	SETPOINT FEEDBACK		ENTER
Traverse channels	SETPOINT FEEDBACK ACTUAL VALUE FEEDBACK	SETTING	Switch 1 - 4
Channel 5 setpoint adjustable	DISPLAY CHANNEL 5	SETTING	Switch 2
Scanning of serial No.	ACTUAL VALUE FEEDBACK	MONITORING DISPLAY AUTOMATIC	ENTER
Call up flame intensity	ACTUAL VALUE FEEDBACK	AUTOMATIC	Channel 3 up



## 10 Appendix

### 10.5.2 O<sub>2</sub> Trim

Action	Mode	Position higher switch	Position lower switch	Keys / Others
Mode switch-off O <sub>2</sub> trim VMS/FMS		STATUS	AUTOMATIC or O <sub>2</sub> TRIM	Channel 3 key (5) OPEN → O <sub>2</sub> TRIM CLOSE → VMS/FMS
O <sub>2</sub> error reset	O <sub>2</sub> TRIM	STATUS	AUTOMATIC	O <sub>2</sub> trim mode Press ENTER (3) and query cause of error Channel 3 switch (5) → OPEN
Calling up text messages	O <sub>2</sub> TRIM	STATUS	AUTOMATIC or O <sub>2</sub> TRIM	ENTER
Adjusting correc- tion value	TK	FIRING RATE	O <sub>2</sub> TRIM	Channel key 1 OPEN → Excess air CLOSE → Air shortage
Changing O <sub>2</sub> tar- get value to 'adjust' SETTING	T	STATUS	O <sub>2</sub> TRIM	Channel key 3 OPEN → more O <sub>2</sub> CLOSE → less O <sub>2</sub>
Calling up O <sub>2</sub> trim error history	VMS/FMS	STATUS	AUTOMATIC	Channel key 2 upwards / down- wards, you can view the fault history with channel key 1, and call up the text with ENTER key.
Change setpoint of burner firing- rate controller	FIRING RATE	CONTROL MODE		Channel key 3 OPEN and channel key 4 CLOSE: When the display blinks with the channel key 2 UP, set the setpoint and save with the ENTER key.

10.6 Process Sequence Charts

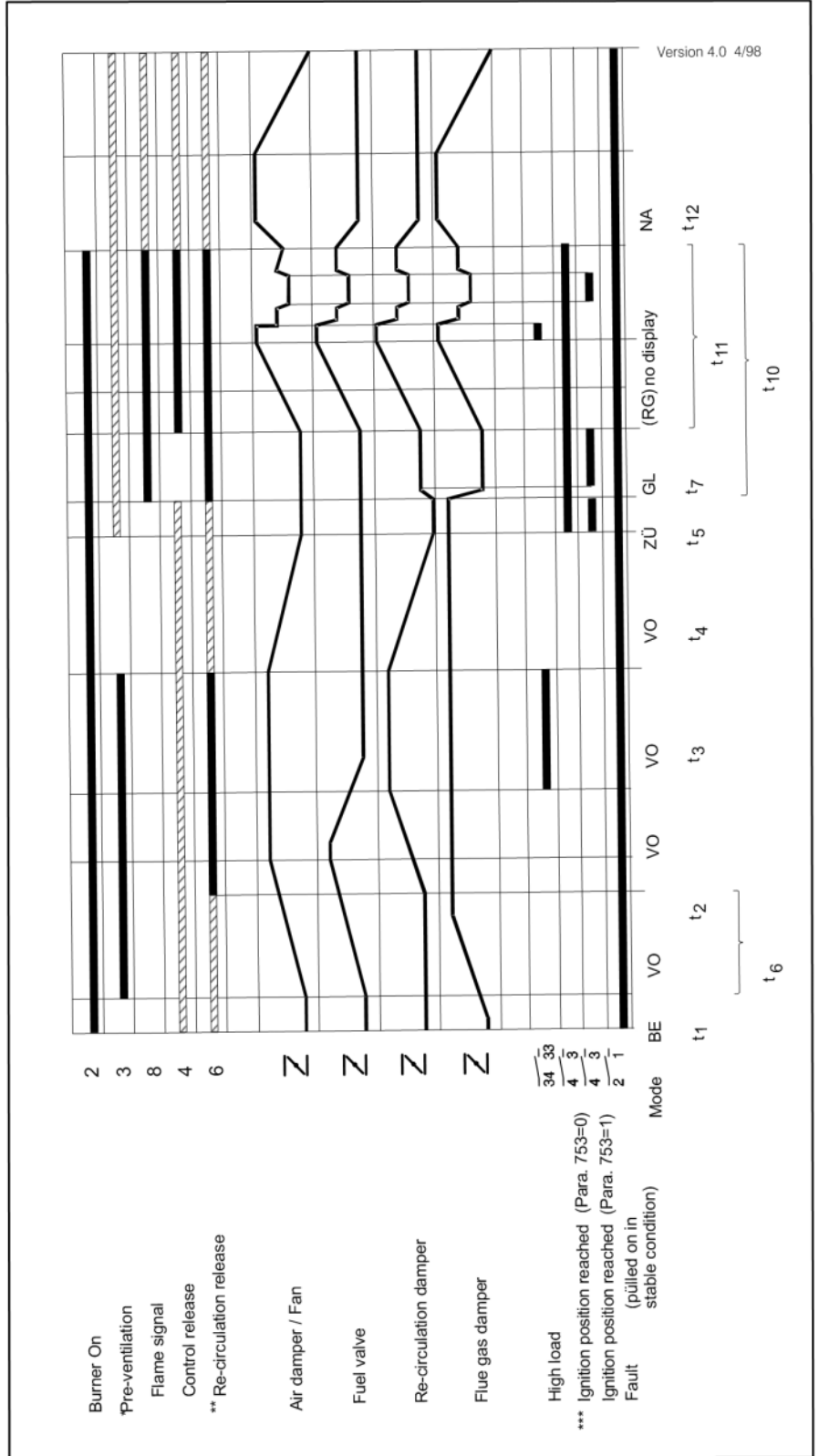



Fig. 10-3 Sequence of functions VMS digital inputs (sequencer)

Legend of the process sequence chart		
	Any condition	
t1	Readiness	
t2	Running time, servo actuator	
t3	Pre-purge time	
t4	Running time, servo actuator	
t5	Ignition position	
t6	Retardation of the re-circulation damper	
t7	Base firing rate	
t10	Operating phase	
t11	Control mode	
t12	Post-purge time (optional)	0 - 255 s, adjustable

### Footnotes of the process sequence chart

- \* If the ducts run closed after a shut-off, the pre-purge signal is ignored until they have reached the lower monitoring threshold.
- \*\* In the absence of the re-circulation signal, the re-circulation dampers remain closed or run closed (even in pre-purge). The extend to which re-circulation is retarded during pre-purge compared to the air damper, can be set via parameter "VODeIR (No. 427) "0".
- \*\*\* Parameters can be used to select whether the signal is to function as a limit switch or whether it is always present after ignition.

10.7 Wiring of the Analogue Inputs

The following circuit diagrams are universal. They do not refer to the use of the respective channels.

In addition all analogue inputs (except correction) are drawn for potentiometer connection. If current is used as input quantity on some channels, the respective inputs have to be wired as shown below.

Where current is used as feedback signal in place of a potentiometer:

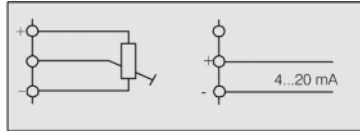

Where a three-point step signal from the firing rate control unit is used as firing rate input, the contacts are to be connected as follows in place of the firing rate potentiometer:

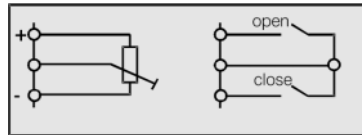

Where a 4 ... 20 mA unit is to be supplied with 24 V (optional):

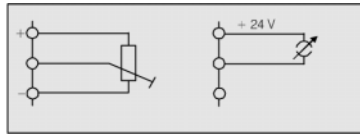

Where the speed feedback is not by way of 0/4 ... 20 mA but through integral speed sensing (direct switching of a Namur transmitter) (optional):



Where the speed feedback is not by way of 0/4 ... 20 mA but through integral speed sensing (inductive sensor with three wire system) (optional):

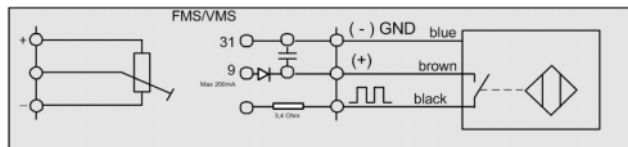

Suitable intermediate terminal: 663R1193

Where an input is configured as PT 100 (optional):

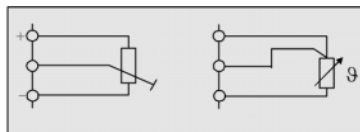



# 10 Appendix

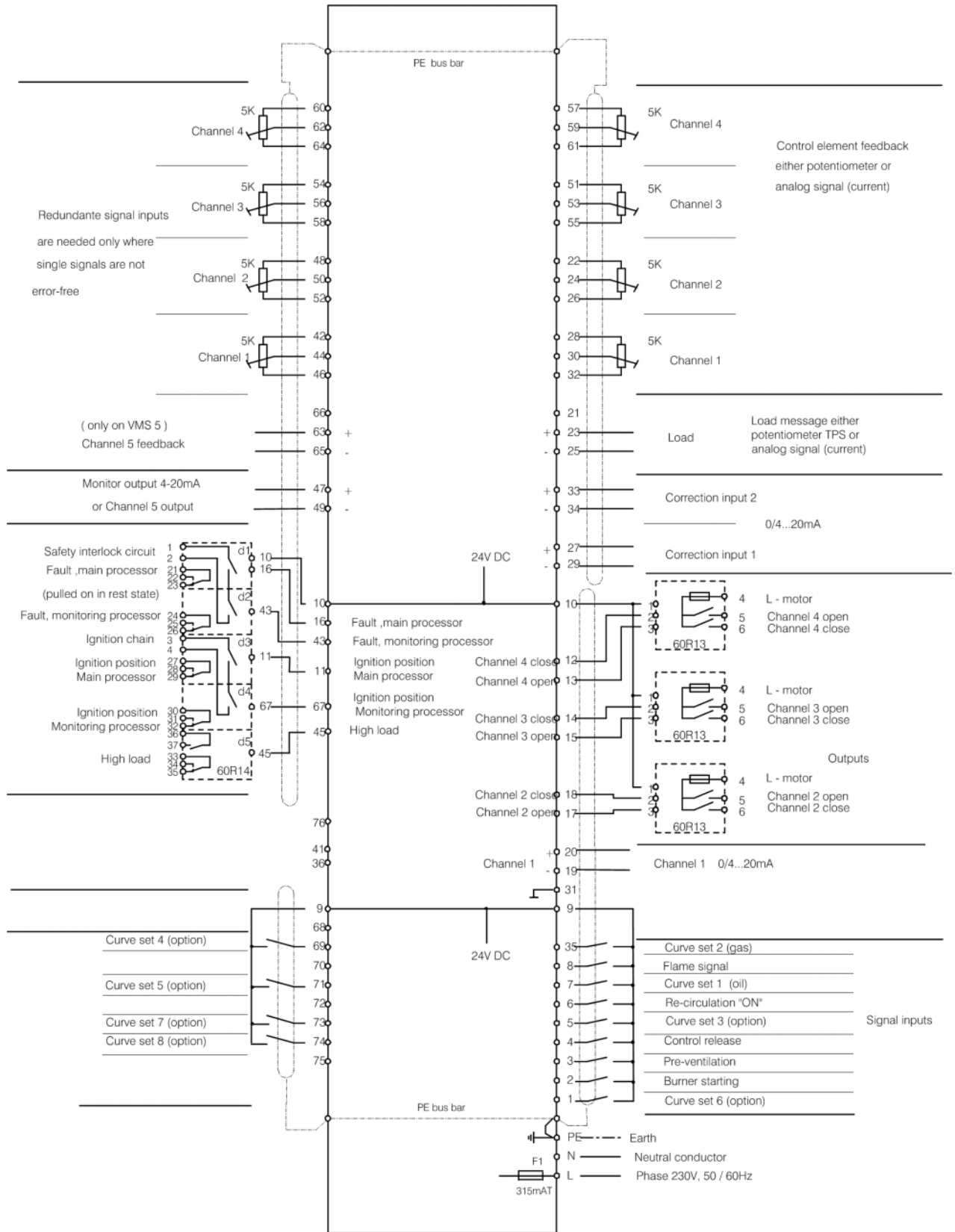

Fig. 10-5 Gerät 4 Type 664 V 0020 with 1 continuous control output and 3 three-point step control outputs  
Gerät 5 Type 665 V 0020 with 2 continuous and 3 three-point step control outputs

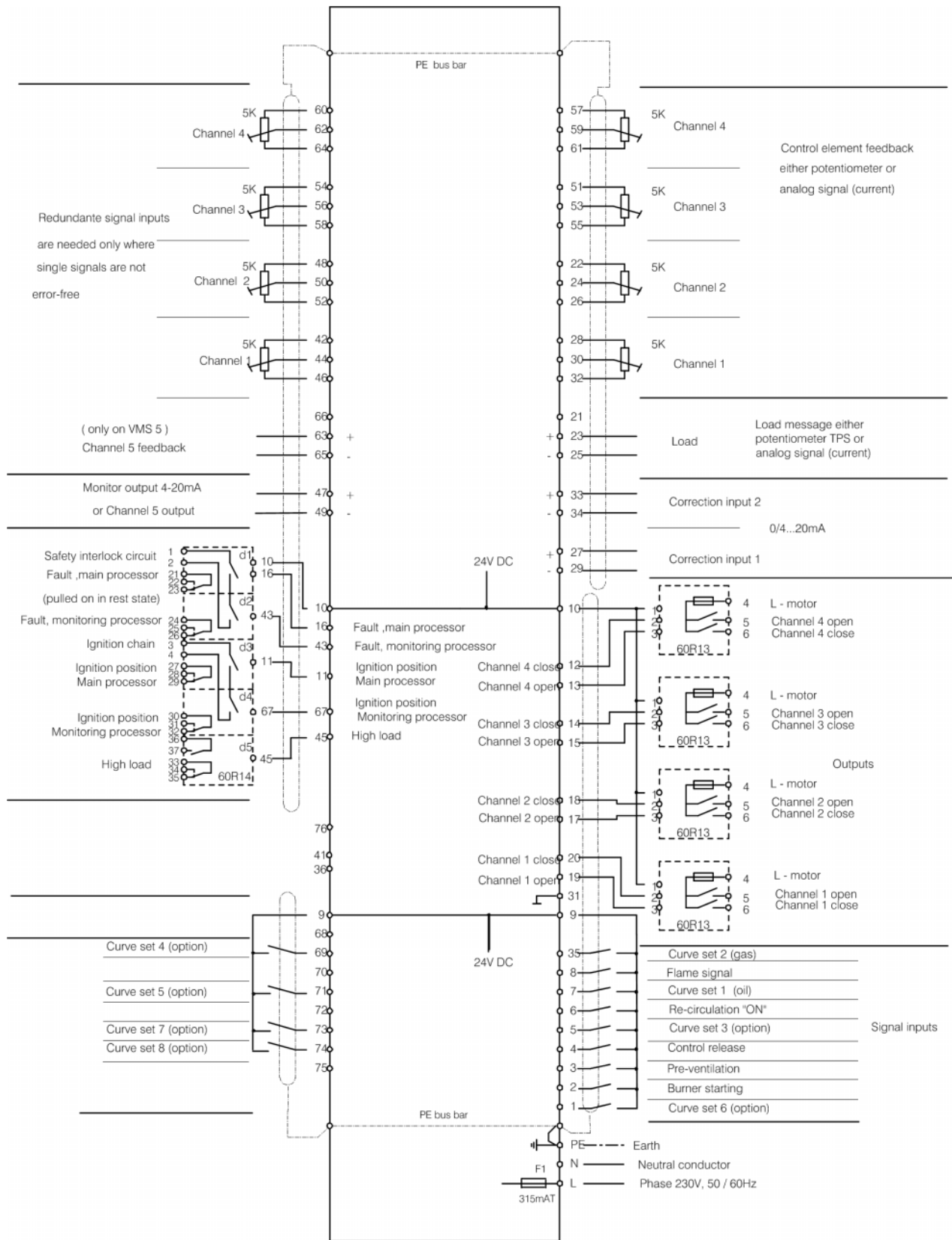

Fig. 10-6 Gerät 4 Type 664 V 0030 with 2 continuous and 2 three-point step control outputs  
Gerät 5 Type 665 V 0030 with 3 continuous and 2 three-point step control outputs

# 10 Appendix

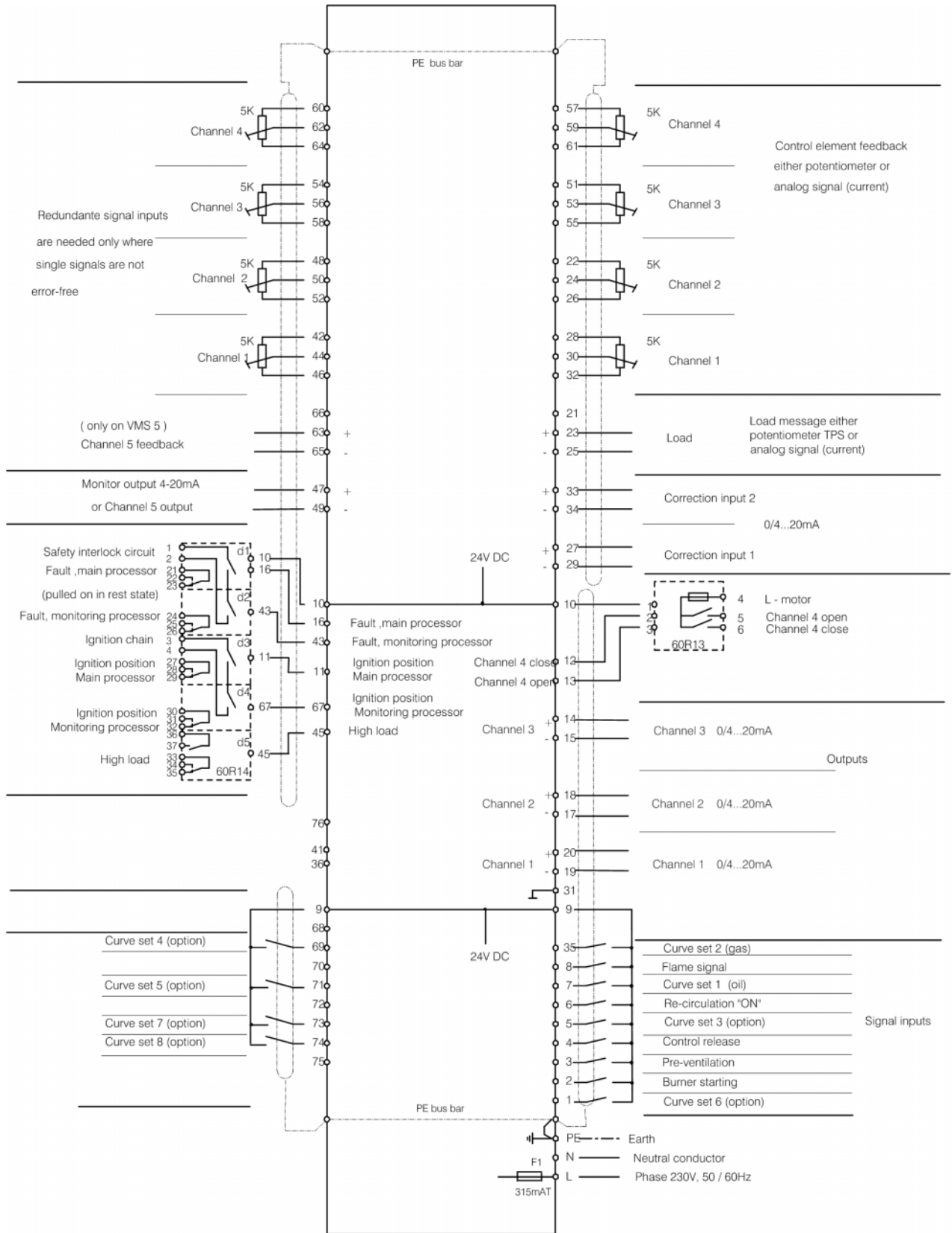

Fig. 10-7 Gerät 4 Type 664 V 0040 with 3 continuous and 1 three-point step control output  
Gerät 5 Type 665 V 0040 with 4 continuous and 1 three-point step control output

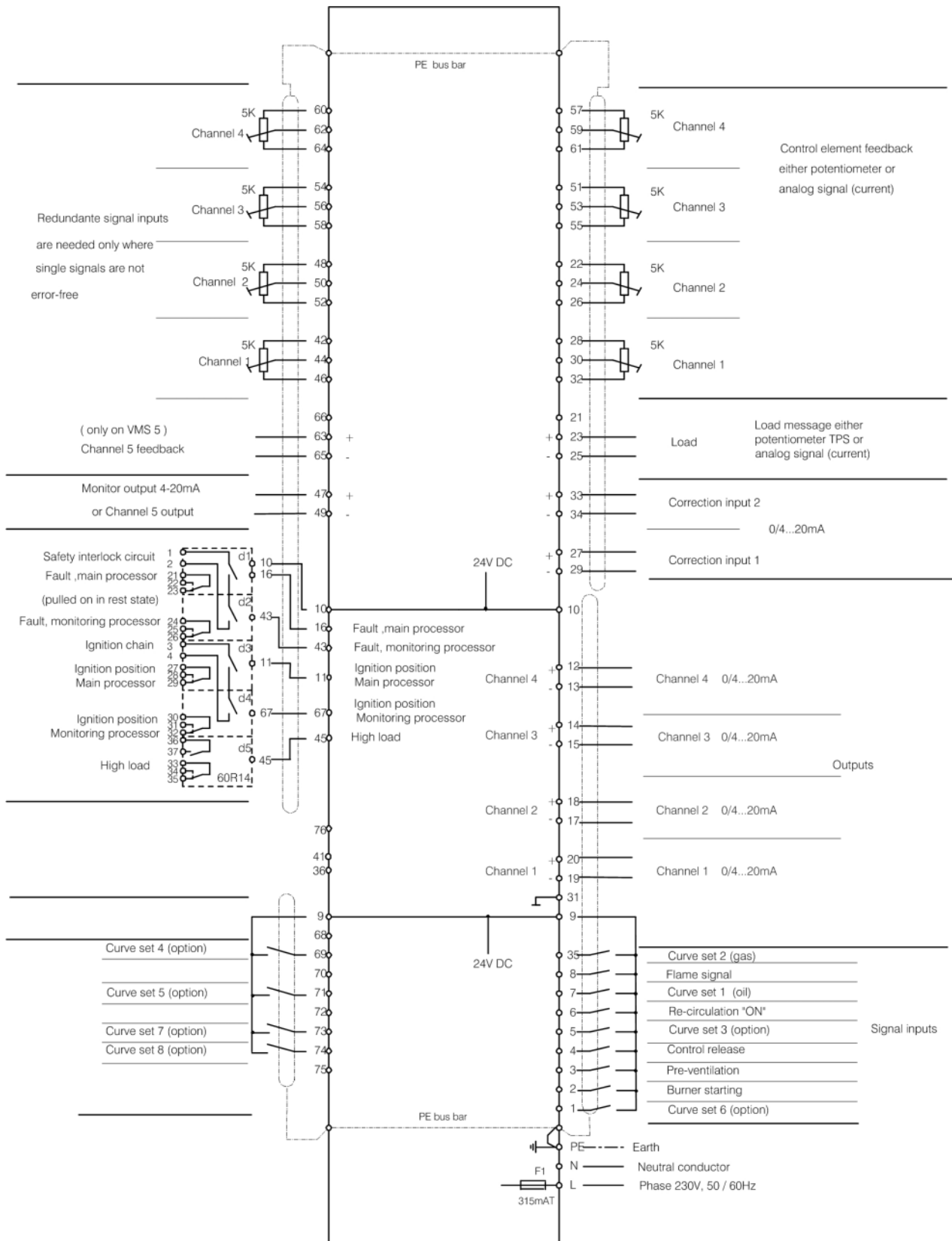

Fig. 10-8 Gerät 4 Type 664 V 0050 with 4 continuous control outputs  
Gerät 5 Type 665 V 0050 with 5 continuous outputs

# 10 Appendix

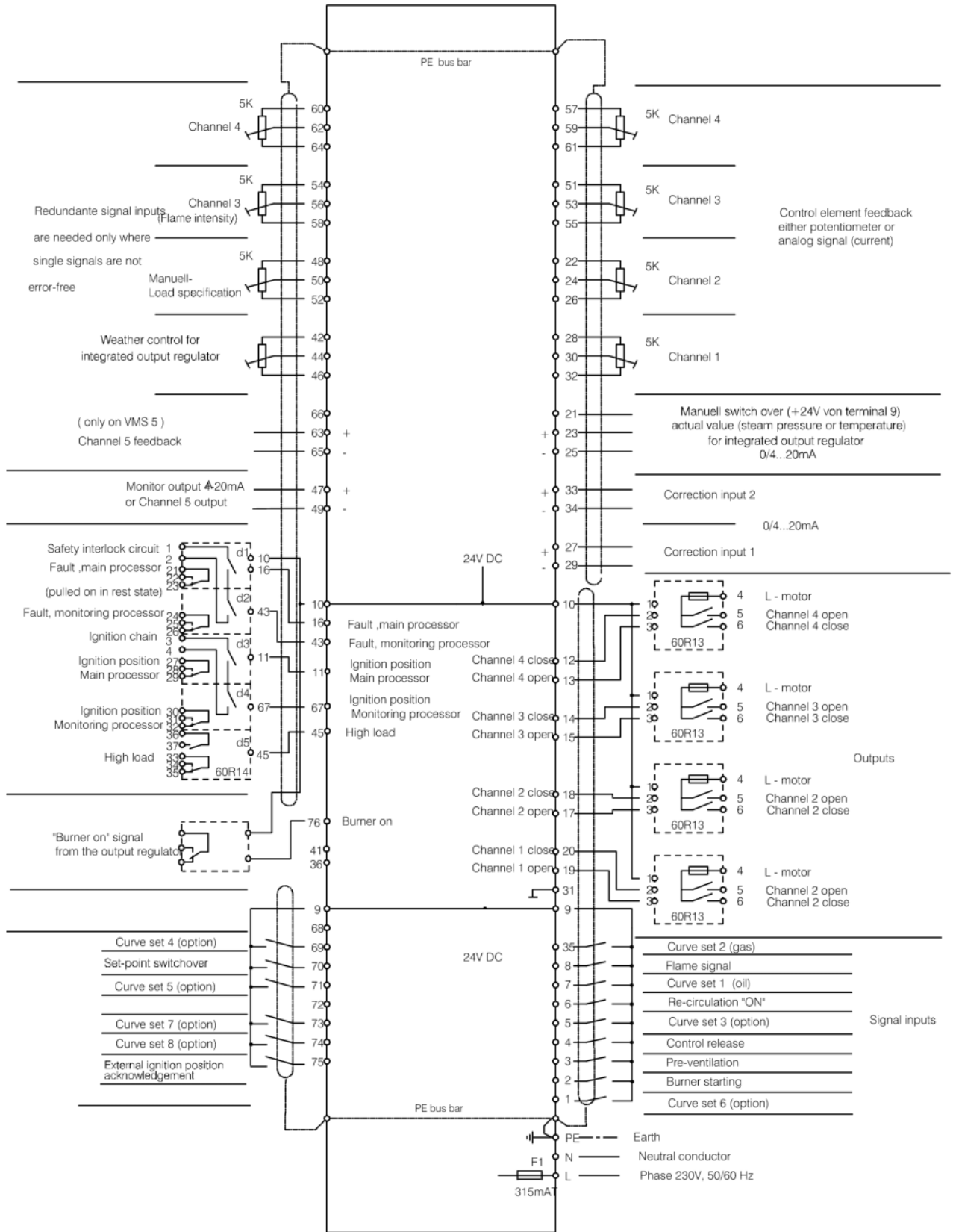

Fig. 10-9 Gerät 4 Gerät 5 with output regulator

## 10.9 R. P. M. Sensor

### 10.9.1 Direct Connection to R. P. M. Sensor

(old version delivered up to Sept. 03)

This option allows you to connect an inductive sensor of the company Turck as a speed feedback. On this configuration card 3 speed/ pulse ranges can be set at the factory.

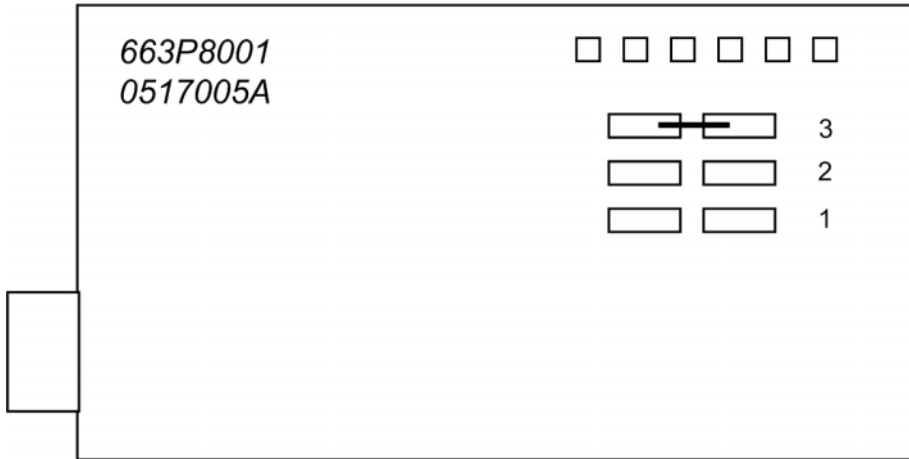

Fig. 10-10 R.p.m. sensor 663P8001 delivered up to September 2003

Speed nominal range (164... 819 Digit)

- I 300 ... 3000 pulses/min (Standard)
- II 800 ... 4000 pulses/min (Standard)
- III 1000 ... 8000 pulses/min

Range which is theoretically, technically possible (140-941 Digit)

- I 200 ... 3500 pulses/min
- II 680 ... 4600 pulses/min
- III 740 ... 9310 pulses/min

Only 2 wire NAMUR.

If the set pulse range is exceeded the value remains at the upper end of the range (higher pulse numbers are ignored).

Below the measuring range the signal goes to 0 (approx. 0 - 7 digit).



#### CAUTION!

Make sure that the selected measuring range is not exceeded, otherwise speed changes in excess of this will no longer be detected.

#### Technical Data

NAMUR input:	Technical Data NAMUR input: $U_0 = 8,2 \text{ V}$ ; $I_k = 8,2 \text{ mA}$ , +/- 5 %
Make threshold:	max. 2,1 mA (type 1,8 mA)
Break threshold:	max. 1,2 mA (type 1,4 mA)
Linearity error:	< 0,1 % v. E.
Temperature drift:	< 75 ppm/K (type 60 ppm/K)

**(new version delivered from October 2003 onwards)**

In , a r.p.m board can be integrated, allowing you to connect an inductive sensor for speed feedback directly. It could be a NAMUR type or a three wired type.

Speed nominal range (164... 819 Digit)

S1.1	15-440	pulses/min	⊥	140 to 942 Points	(0,25...7.3 Hz)
S1.2	45-1320	pulses/min	⊥	140 to 942 Points	(0,75...22 Hz)
S1.3	175 - 4200	pulses/min	⊥	140 to 942 Points	(2,9...70 Hz)
S1.4	355 - 8430	pulses/min	⊥	140 to 942 Points	(5,9...140,5 Hz)

Additionally, there are 2 DIP switch for changing between NAMUR and three wire connection.

- S2.1 and S2.2 at OFF → three wire system
- S2.1 and S2.2 at ON → NAMUR



Fig. 10-11 R.p.m. board from October 2003 onwards

If the set pulse range is exceeded the value remains at the upper end of the range (higher pulse numbers are ignored). Below the measuring range the signal goes to approx. 0 - 7 digit.

**⚠ WARNING!**

Make sure that the selected measuring range is not exceeded, otherwise speed changes in excess of this will no longer be detected.

Technical Data	
Linearity error:	< 0,1 % v. E.
Temperature drift:	< 75 ppm/K (typical 60 ppm/K)
NAMUR-input:	$U_0 = 8,2 \text{ V}$ ; $I_k = 8,2 \text{ mA}$ , +/-5 %
Make threshold:	max. 2,1 mA (typical 1,8 mA), +/-5 %
Break threshold:	max. 1,2 mA (typical 1,4 mA), +/-5%
Switch input:	
Make threshold:	6,2 V
Break threshold:	4,5 V
Measuring method:	Period duration measurement over 5 periods
Input pulse width:	>200 $\mu\text{s}$
Temperature range:	0...60 °C/32°F...140°F

## Technical Data

Usable NAMUR transmitters:	all Turck sensors, which contain Y0 or Y1 in their type designation.
----------------------------	--

Owing to the large number of usable transducers LAMTEC has only one two wire element and one three wire element in its product range. It is selected in that way, that it covers a number of measuring tasks. Other transducers only on enquiry or direct from the company Turck.

Item no.	Description
660R8101	r.p.m. sensor as a two wire system d = 12 mm, switch gab 2 mm
663R8103	inductive sensor with switch terminals in three wire system d = 12 mm, switch gab 4 mm

### 10.9.2 Selection of a Suitable R. P. M. Sensor

The correct sensor should always be selected, taking into account the structural features of the element to be measured.

Since this element is not always known, the following is an approximation procedure for dimensioning the attenuating elements and selecting a suitable sensor.

In most cases, a shaft is sensed directly. One or several attenuating elements (screw-heads or metal plates) are attached directly to the shaft. A symmetrical arrangement should be ensured, since many instruments work on the principle of measuring the period, and in the case of more than one attenuating element require 100% equal intervals between them.

If this cannot be guaranteed, the signal can exhibit jumps (asymmetry can become particularly noticeable in analogue signals). This problem can be solved by installing only one attenuating element (this is the standard setting for rev. speed capture in the VMS).

#### Example of an attenuating element:

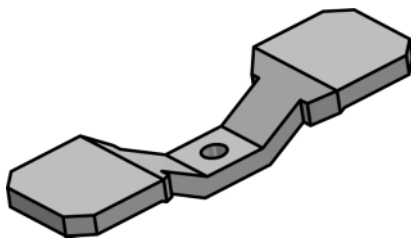

Fig. 10-12 Attenuating element (example)

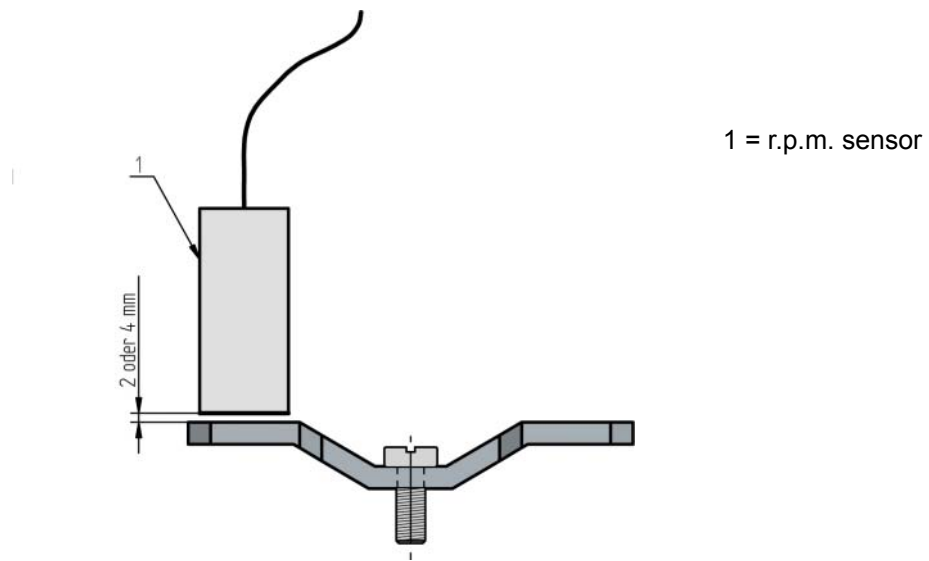

Fig. 10-13 Position r.p.m. sensor to the attenuating element

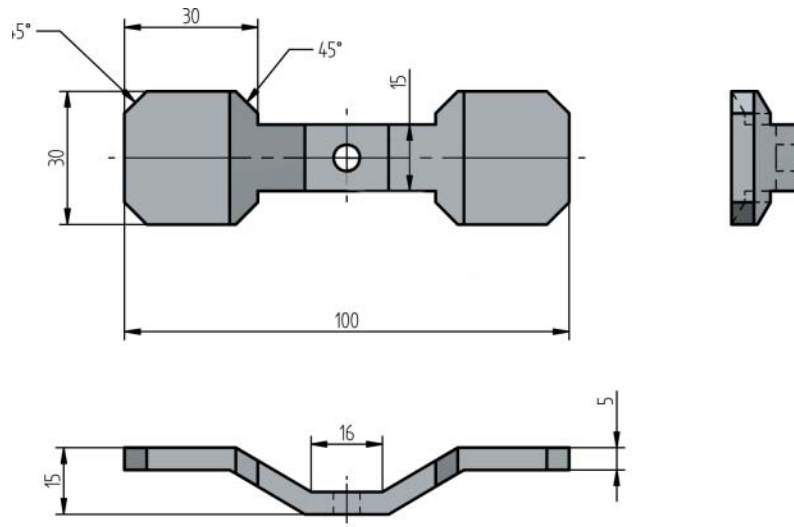

Fig. 10-14 Dimensional drawing attenuating element for our example

The illustration (left) shows a typical arrangement of attenuating element, sensor and shaft.

How the system works:

Every inductive sensor forms an electric field at its active surface, from which the contact gap (nominal contact gap "Sn") can be derived as a function of sensor size. The table lists several typical sensors with their characteristics. The effective contact gap is 0.8 x nominal contact gap in the case of structural steel. An additional correction factor that depends on the material must be included for other materials. These factors are specified in the sensor manufacturer's data-sheets.

The installation distance between the sensor and the attenuating element's upper edge should be  $S_n/2$  (half the nominal contact gap). The sensor's diameter depends on the required nominal contact gap and can be derived from the table. The attenuating element's diameter should be equal to or greater than the sensor's diameter (for frequencies < 20% of the sensor's maximum switching frequency).

The height of the attenuating element should be at least  $3/4$  of the  $S_n$  (nominal contact gap). If this height is not assumed, the sensor can detect the shaft or it will be attenuate by the shaft until the secured r.p.m. recognition is not assumed any longer.

Under certain circumstances, this fault can be first recognised though higher r.p.m.

## Selective list of Turck NAMUR sensors

Type	sn [mm]	sn x 0,8 [mm]	D [mm]	f [Hz]	Installation
Bi1-EG05-Y1	1	0,8	5	5.000	flush
Bi1,5-EG08K-Y1	1,5	1,2	8	5.000	flush
Ni3-EG08K-Y1	3	2,4	8	5.000	non-flush
Bi2-G12-Y1	2	1,6	12	5.000	flush
Ni5-G12-Y1	5	4	12	2.000	non-flush
Bi5-G18-Y1	5	4	18	1.000	flush
Ni10-G18-Y1	10	8	18	500	non-flush
Bi10-G30-Y1	10	8	30	500	flush
Ni15-G30-Y11	15	12	30	200	non-flush

### 10.10 Connection Diagram Relay Modules

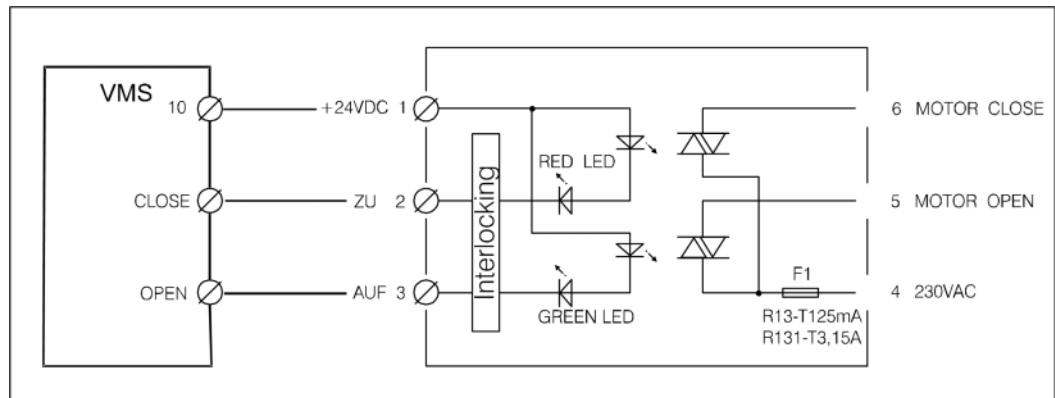

Fig. 10-15 Relay module type 660 R 0013 / 660 R 0131

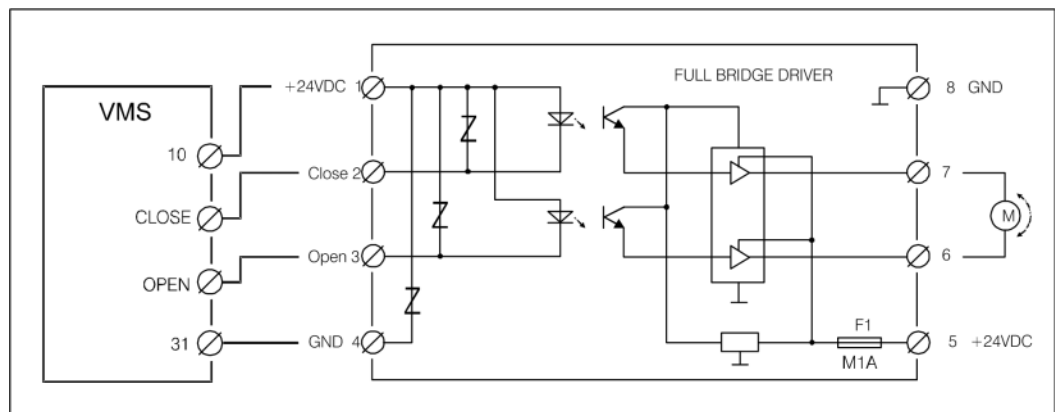

Fig. 10-16 Relay module type 660 R 0019

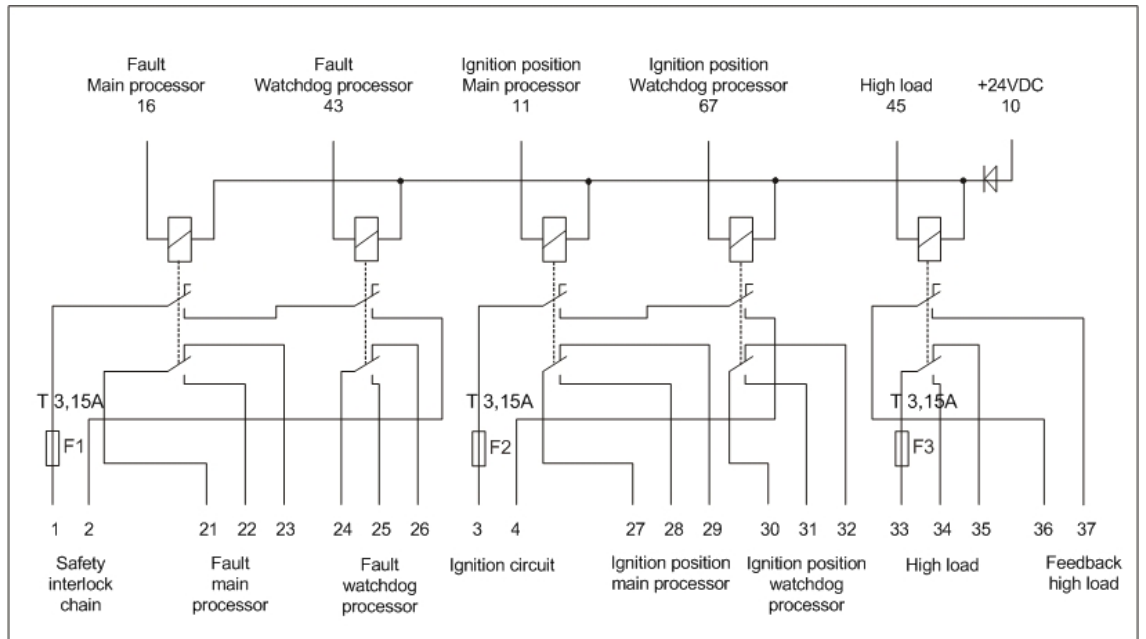

Fig. 10-17 Relay module type 660 R 0014

### 10.11 Modem Connection Plan for Remote Access



Fig. 10-18 Modem for remote control

A connection with VMS via modem is also possible. The industrial modem (optional) for mounting on top hat rail allows the access to 31 devices at the same time with a LAMTEC tool for Windows. This tool realizes the remote control of the operating mode of the devices

The wiring between modem and RS422 module (interface adapter) is provided by the customer. Use a 4-wire, twisted and shielded cable.

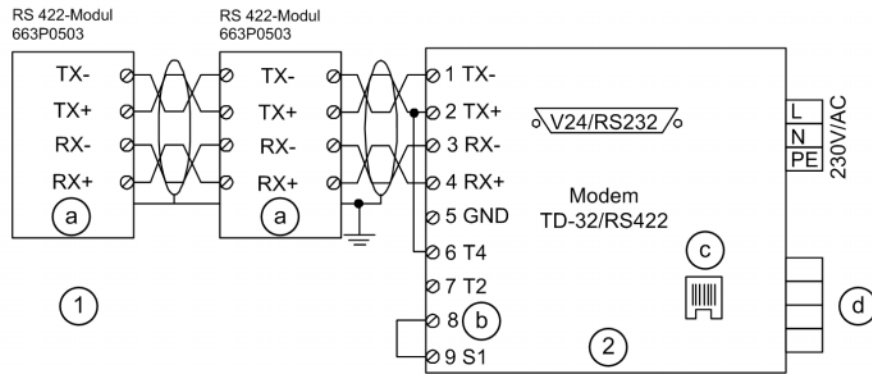

Fig. 10-19 connection diagram modem for remote control

No.	Description
1	with termination resistors, setting via DIP switch
2	adjustment of the modem's DIP switch:
	SW1 dial-up connection 0000
	SW2 all without function 0000 0000
	SW3 tel. connection, 2-wire cable 1000 0000
	SW4 19200 baud, 8N 1110 1100
	SW5 automatic speed adaptation 1111 0000
a	shield
b	2/4 wire
c	telephone line
d	leased line

10.12 Technical Data



Fig. 10-20 VMS

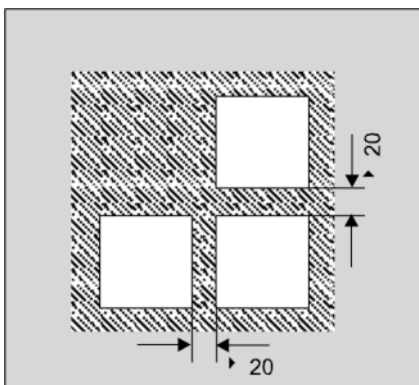

Fig. 10-21 Minimum spacing between several cut-outs

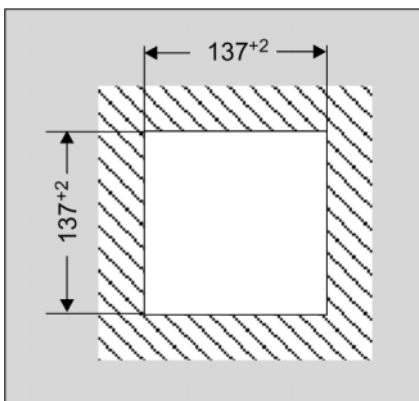

Fig. 10-23 Single cut-out

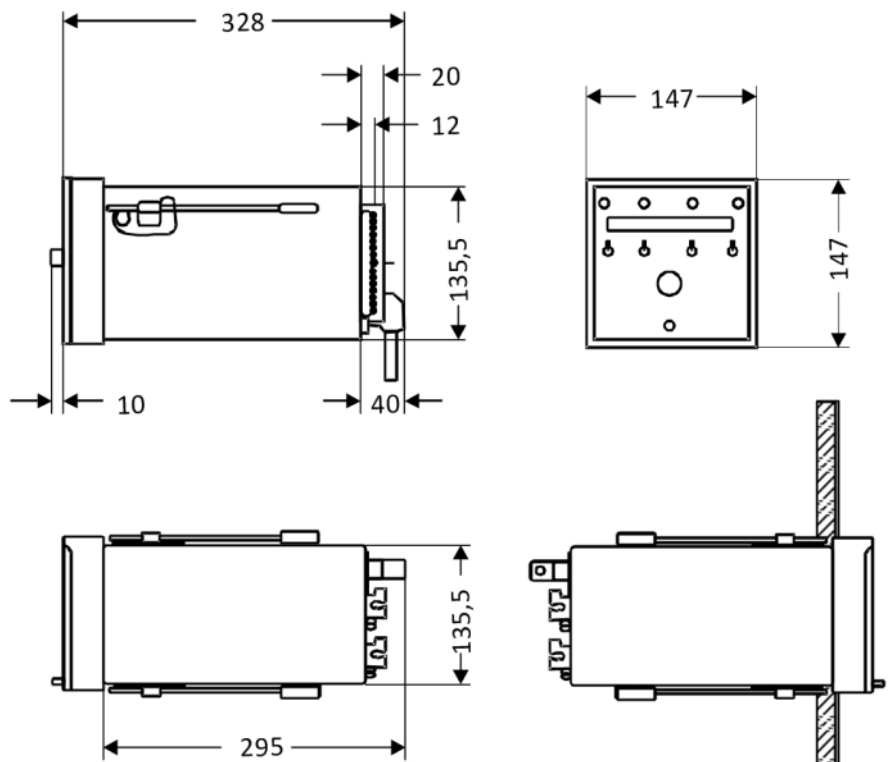

Fig. 10-22 Dimensional drawing VMS

## 10 Appendix

<b>Dimensions</b>	
Dimensions (H x B x T) [mm] [in.]	147 x 147 x 328 (5.8 x 5.8 x 12.9)
Weight [kg]	
Material	
<b>Input data</b>	
Voltage supply (optional)	230 V +10 % - 15 % 50/60 HZ To be used only in a grounded power line network!
Power consumption	ca. 34 VA
<b>Characteristics</b>	
Display	16-character alphanumeric display, switchable to target value, firing rate value, status, actual value, feedback, target value feedback, digital inputs, continuous positioning output value, correction input and correction range. Running text display.
Inputs (digital/analogue)	16 digital inputs 12 analogue inputs all none isolated
Digital signal inputs	16 via isolated relay contact (24 VDC), or optionally via 230 V module, type 660R0018
Correction inputs	2, adjustable to 0 ... 20 or 4 ... 20 mA Channel an action parametrically adjustable
Firing rate preset	Selectable – potentiometer 1 - 5 k $\Omega$ , – current signal (0/4 ... 20 mA) or – three-point-step positioning output Optional: PT100 direct actuation (when using the firing-rate-controller)
Analogue inputs	Selectable – potentiometer 1 - 5 k $\Omega$ , – current signal 0/4 ... 20 mA. Optional: Namur transducer direct actuation, PT100 direct actuation
Resolution per analogue input	999 digits, 10 Bit
Positioning outputs	4 or 5, selectable between continuous or three-point-step, in VMS 5 channel 5 always continuous.
Three-state-step Recommended run time of the positioning drivers	30 s ... 60 s
Outputs (digital/analogue)	8 - 16 digital outputs 1 - 5 analogue outputs all none isolated
Continuous output firing rate	0 ... 10 V > 5 k $\Omega$ 0/4 ... 20 mA < 600 $\Omega$
Signal outputs	Faults Ignition point Open valves / flaps high fire position

## 10 Appendix

<b>Characteristics</b>	
Storage of the target values and variable data	In EEPROM up to 20 points per curve with linear interpolation
Number of programmings	2 per channel (e.g. for oil/gas combined burner) Optionally 4 and 8
Number of programmings	Unlimited (EEPROM)
Interface	2 serial interfaces on 25-pole Sub-D socket only addressable via adapter RS232 (standard setting 19200 baud, even parity, 8, 1) and AMTEC SYSTEM BUS
BUS coupling	Via 25-pole Sub-D socket Optional BUS card for the following systems: INTERBUS-S (Phoenix) PROFIBUS DP Modbus Ethernet (Modbus TCP)

<b>Environmental conditions</b>	
Ambient temperature	
– Operation	+0 °C ... +60 °C (32 °F ... 140 °F)
– Transport and storage	-25 °C ... +60 °C (-13 °F ... 140 °F)
Permiss. ambient humidity	Class F, DIN 40 040

### 10.13 Accessories and Spare Parts

<b>Accessories for VMS</b>	<b>Oder no.</b>
Novotechnik potentiometer 5 k $\Omega$ , für VR, VMS/FMS TÜV approved	660P7001
Contelec potentiometer 5 k $\Omega$ , for VR, VMS/FMS TÜV approved	660P7003
Contelec potentiometer 5 k $\Omega$ ,for VR, VMS/FMS TÜV-approved, short axis for conversion of L & G motors	660P7002
Contelec-Potentiometer 5 k $\Omega$ to 90° for conversion of Autoflame motors	660P7004
Servomotor 12 Nm, running time 60 s to 90°, 2 limit switches, incl. TÜV approved potentiometer	662R2110
Servomotor 19 Nm, running time 60 s to 90°, 2 limit switches, incl. TÜV-approved potentiometer	662R2111
Servomotor 30 Nm, running time 60 s to 90°, 3 limit switches, manual operation, incl. TÜV approved potentiometer	662R2112
Buffer amplifier TUI 21 (0 ... 20 mA/0 ... 20 mA)	655R0100
Buffer amplifier TUI 21 (input and output set at factory)	655R0101
Module for signal inputs 230 V	660R0018
PC Remote Software for VMS/FMS	663R9000
PC Remote Software for VMS/FMS (end user version)	663R9001

<b>Spare parts for VMS</b>	<b>Order no.</b>
Fuses 1 A, T for VMS/FMS, 24 V supply (package of 10)	660R0110
Fuses 0,315 A, T for VMS/FMS, 230 V (package of 10)	660R0116
Fuses 3,15 A, T for relay module 660R0011/R0012/R0014/R0131 (package of 10)	660R0115
Fuses 80 mA, T for relay module 660R0013 (package of 10)	660R0113
Fuses 2 A, T for relay module 660R0016 (package of 10)	660R0114
Fuses 0,5 A, T for relay module 660R0016 (package of 10)	660R0117
Program Up-Date VMS/FMS	663R3100
Plug connector 18 pole for VMS/FMS	655P9211

## 10 Appendix

Spare parts for VMS		Order no.
Panel mounting fixture (package of 2)		660R0080
Setpoint memory (EEPROM) for VMS/FMS		662R0111
Spare power supply electronics for VMS/FMS		663P0923
Spare computer electronics for VMS/FMS		663P0921
Continuous output electronic card for VMS/FMS		663P7000
Front electronic for VMS/FMS complete		663P5000
Spare backplane for VMS/FMS		663R3000
	Pt 100 module	657P0898
	r.p.m. module Namur	663P8001A
	r.p.m. module 3-wire	663P8003
	DPS	663P8004
Universal modules for analogue inputs:	Potentiometer 5k $\Omega$	663P6000
	0/4 ... 20 mA	663P6001
	0/4 ... 20 mA with 24 V supply for transmitter	663P6002
	0/4 ... 20 mA with manual switch over	663P6003
Null modem cable 10 m		663R0100
Extension 10 m		663R0101

## 10.14 Declaration of Conformity



### EG-Konformitätserklärung

EC Declaration of Conformity  
Déclaration CE de Conformité

Wir (We / Nous)

**LAMTEC Meß- und Regeltechnik für Feuerungen GmbH & Co. KG**  
**Wiesenstraße 6**  
**D-69190 Walldorf (Baden)**

erklären, dass das  
(declare that)  
(déclarons que)  
inkl.  
(inclusive)  
(y compris)

**VMS – Verbund-Management-System**

**den Erweiterungsmodulen:**  
(additional modules, modules complémentaires)  
**- R13**  
**- R14**  
**- R131**  
**- Kommunikationsprozessor**

Produkt-ID-Nummer:  
(Product Id Number)  
(Numéro d'identification du produit)

<b>VMS</b>	<b>664V00 / 665V00</b>
<b>R13</b>	<b>660R0013</b>
<b>R14</b>	<b>660R0014</b>
<b>R131</b>	<b>660R0131</b>
<b>Kommunikationsprozessor</b>	<b>663P0401</b>

auf welche sich diese Erklärung bezieht, mit den folgenden Norm(en) übereinstimmt  
(to which this declaration relates conforms to the following standard(s))  
(sur laquelle cette déclaration se réfère, et conformément aux dispositions de la norme(s))

DIN EN 12067-2: 2004-06  
DIN EN 13611: 2011-12  
DIN EN 60730-2-5: 2011-03  
DIN EN 60730-1: 2012-10

LAMTEC Meß- und Regeltechnik für Feuerungen  
GmbH & Co. KG  
Wiesenstraße 6  
D-69190 Walldorf (Baden)

Telefon: +49 6227 6052-0  
Telefax: +49 6227 6052-57

Internet: [www.lamtec.de](http://www.lamtec.de)  
E-Mail: [info@lamtec.de](mailto:info@lamtec.de)



gemäß den Bestimmungen der folgenden Richtlinie(n).  
 (according to the provisions of the following directive(s))  
 (conformément aux dispositions de la directive(s))

Nummer (Number / Numéro)	Text (Text / Texte)
2014/35/EU	Niederspannungsrichtlinie
2014/35/EU	Low Voltage Directive
2014/35/UE	Directive basse tension
2014/30/EU	EMV-Richtlinie
2014/30/EU	EMC Directive
2014/30/UE	Directive CEM
2014/68/EU	Druckgeräterichtlinie Kat.4 Mod. B+D
2014/68/EU	Pressure Equipment Directive
2014/68/UE	Directive équipements sous pression
2009/142/EG	Gasverbrauchseinrichtungen
2009/142/EC	Gas Appliance Directive
2009/142/CE	Directive appareils à gas

Das Datenblatt und gegebenenfalls die Basisdokumentation sind zu beachten.  
 (The data sheet and basic documentation, if any, have to be considered.)  
 (La consultation de la fiche technique, et éventuellement de la documentation technique de base, est requise.)

Hinweise zur Anwendung der Richtlinie 2014/35/EU und 2014/30/EU:  
 Die Konformität mit 2009/142/EG setzt die Übereinstimmung mit 2014/35/EU voraus und beinhaltet diese.  
 Die Konformität mit 2014/30/EU ist nach Einbau des Bauteils in das Endgerät nachzuweisen und zu erklären.

Remarks regarding the application of directive 2014/35/EU and 2014/30/EU:  
 Conformity with 2009/142/EC presupposes that requirements of 2014/35/EU are fulfilled and includes these.  
 Conformity with 2014/30/EU has to be proved and declared after installation of the component.

Remarques sur l'application des directives 2014/35/UE et 2014/30/UE:  
 La conformité avec la 2009/142/CE intègre la conformité avec la 2014/35/UE.  
 La conformité avec la 2014/30/UE après l'installation de l'appareil est à prouver et à déclarer.

Anbringung der CE-Kennzeichnung: ja  
 (Placing of the CE marking)  
 (L'apposition du marquage CE)

CE<sub>0038</sub>  
**CE-0085 AS0254**

Walldorf, 19.07.2016  
 H.J. Altendorf, Geschäftsführung

Rechtsverbindliche Unterschrift  
 (Authorised signature) (Signature autorisée)

LAMTEC Meß- und Regeltechnik für Feuerungen  
 GmbH & Co. KG  
 Wiesenstraße 6  
 D-69190 Walldorf (Baden)

Telefon: +49 6227 6052-0  
 Telefax: +49 6227 6052-57

Internet: www.lamtec.de  
 E-Mail: info@lamtec.de

# 10 Appendix

## 10.15 Protocol Example

Date: \_\_\_\_\_ Commissioning technician: \_\_\_\_\_ Plant: \_\_\_\_\_

Location: \_\_\_\_\_ Fuel: \_\_\_\_\_

ID No Type 6 \_\_\_R\_\_\_ Correction range 1: \_\_\_\_\_

Device No. \_\_\_\_\_ Correction range 2: \_\_\_\_\_

Display \_\_\_\_\_

Main processor

Firing rate point	Channel 1		Channel 2		Channel 3		Channel 4		Channel 5		Measurement values at shut-off limits					
	Output	Feed-back	Output	Feed-back	Output	Feed-back	Output	Feed-back	Output	Feed-back	O <sub>2</sub> setpoint	CO value	NO <sub>x</sub>	O <sub>2</sub>	CO	
1																
2																
3																
4																
5																
6																
7																
8																
9																
10																
11																
12																
13																
14																
15																
16																
17																
18																
19																
20																
Lower stop																
Upper stop																
*Dead band/Monitoring Band Air Deficiency Direction																

\* For three-point-step channels, indicate the value of dead band in air deficiency direction (parameter 32-46).  
 For continuous output, indicate the value of monitoring band (parameter 62-76).

10.16 O<sub>2</sub> Setpoint Curves

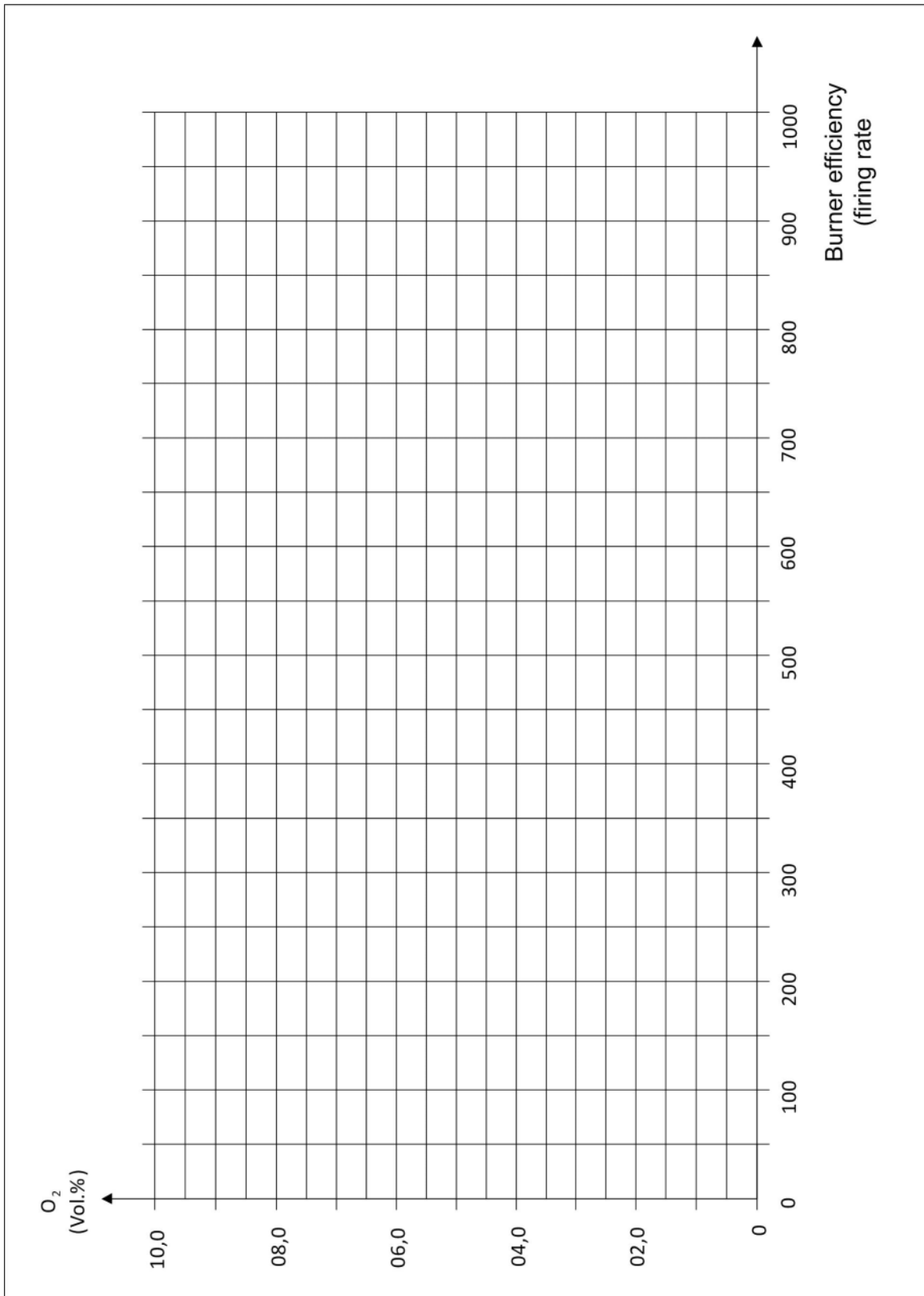



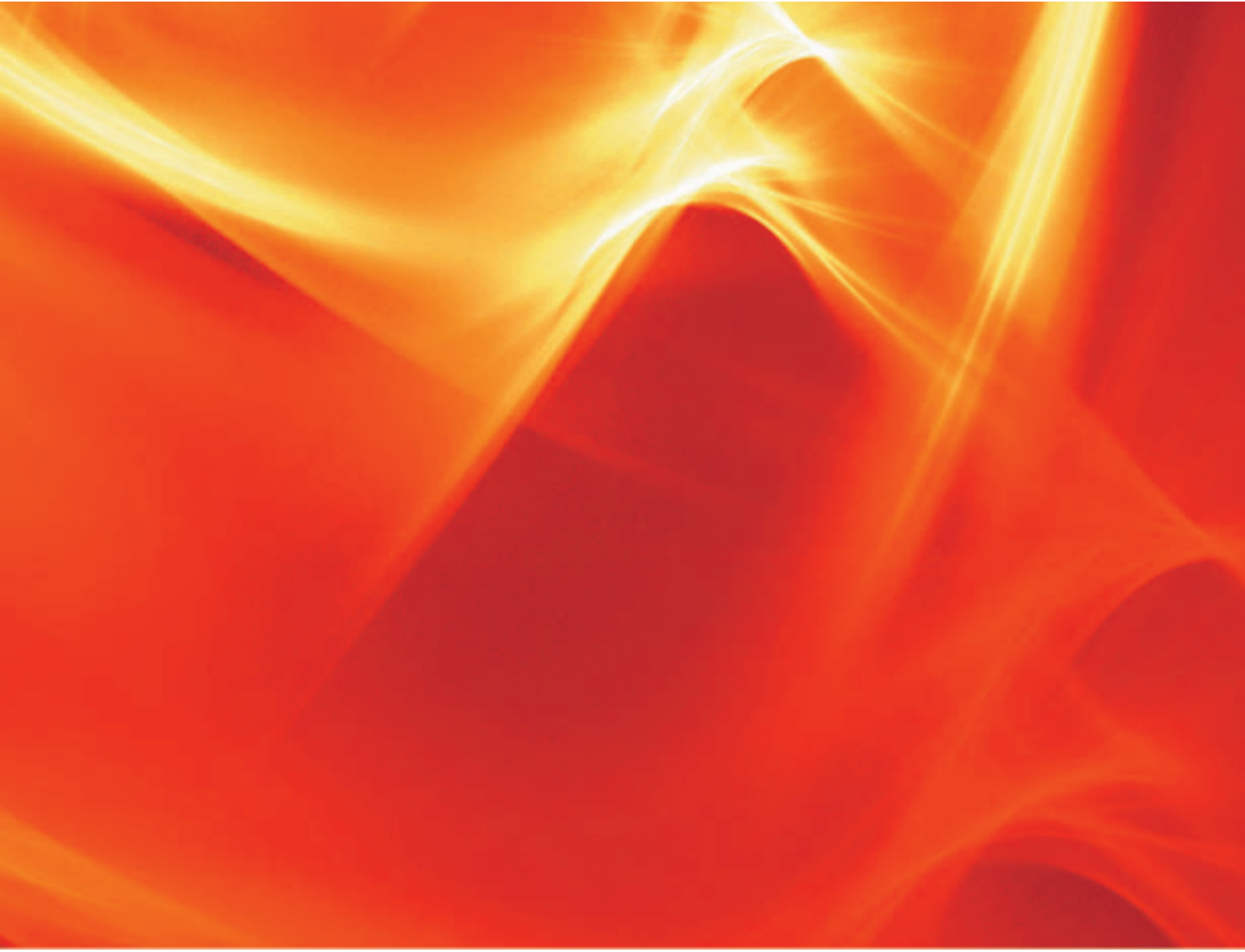

The information in this publication is subject to technical changes.



---

**LAMTEC Meß- und Regeltechnik  
für Feuerungen GmbH & Co. KG**

Wiesenstraße 6  
D-69190 Walldorf  
Telefon: +49 (0) 6227 6052-0  
Telefax: +49 (0) 6227 6052-57

[info@lamtec.de](mailto:info@lamtec.de)  
[www.lamtec.de](http://www.lamtec.de)

